



# TECHNICAL SERVICE MANUAL

## VIKING MAG DRIVE®

### SERIES 855

Sizes AS, AK, AL, KE, KKE

SECTION	TSM 685.2
PAGE	1 OF 16
ISSUE	D

## CONTENTS

Introduction.....	1
Special Information.....	3
Maintenance.....	4
Parts Identification Drawings.....	5-7
Disassembly of Pump.....	7
Disassembly of Coupling.....	8
Disassembly / Assembly Bearing Carrier.....	9-10
Installation of Bushings.....	10
Assembly of Pump.....	10-11
Pump Rotation.....	11
Assembly of Couplings.....	12
Adjusting End Clearance.....	13
Pressure Relief Valve Instructions.....	13-14
Troubleshooting.....	15
Warranty.....	16

## MODEL NUMBER CHART

UNMOUNTED PUMPS	UNITS
AS-855U, AS-855M	Units are designated by the un-mounted pump model numbers followed by the magnetic coupling size and a letter indicating drive style.  (Example: AK-855MA MD2 B50 M )  D = Direct Drive, Base Mounted M = Motor, Face Mounted B = Bearing Carrier R = Viking Reducer Drive P = Commercial Reducer Drive
AK-855U, AK-855M	
AL-855U, AL-855M	
KE-855U, KE-855M	
KKE-855U, KKE855M	
	See Page 4 for complete description of the model number

TABLE 1

### WARNING!

Persons with surgical implants of a metallic or electronic nature should avoid working on pump – especially the inner magnet assembly.

This information must be read fully before beginning any maintenance or repair of the pump. All maintenance or repair must be done by SUITABLY TRAINED or qualified persons only.

## INTRODUCTION

The illustrations used in this manual are for identification purposes only and cannot be used for ordering parts. Obtain a parts list from the factory or a Viking® representative. Always give the complete name of the part, part number and material with the model number and serial number of the pump when ordering repair parts. The unmounted pump or pump unit model number and serial number can be found on the nameplate secured to the pump.

This manual deals only with Series 855 magnetic drive pumps. Refer to Figures 1 through 22 for general configuration and nomenclature used in this manual. Pump specifications and recommendations are listed in Catalog Section 685.

In the Viking model number system, the basic size letters (AS, AK, AE etc.) are combined with the series number (855) indicating basic pump construction material.



FIGURE 1  
SERIES AK855UB MD2-32 B  
Pump with Bearing Carrier



FIGURE 2  
AK SERIES 855UB MD2-14 M  
Pump with Motor Directly Mounted to the Bracket

# SAFETY INFORMATION AND INSTRUCTIONS

IMPROPER INSTALLATION, OPERATION OR MAINTENANCE OF PUMP MAY CAUSE SERIOUS INJURY OR DEATH AND/OR RESULT IN DAMAGE TO PUMP AND/OR OTHER EQUIPMENT. VIKING'S WARRANTY DOES NOT COVER FAILURE DUE TO IMPROPER INSTALLATION, OPERATION OR MAINTENANCE.

THIS INFORMATION MUST BE FULLY READ BEFORE BEGINNING INSTALLATION, OPERATION OR MAINTENANCE OF PUMP AND MUST BE KEPT WITH PUMP. PUMP MUST BE INSTALLED, OPERATED AND MAINTAINED ONLY BY SUITABLY TRAINED AND QUALIFIED PERSONS.

THE FOLLOWING SAFETY INSTRUCTIONS MUST BE FOLLOWED AND ADHERED TO AT ALL TIMES.

Symbol Legend :



**Danger** - Failure to follow the indicated instruction may result in serious injury or death.

**WARNING**

**Warning** - In addition to possible serious injury or death, failure to follow the indicated instruction may cause damage to pump and/or other equipment.



**BEFORE** opening any liquid chamber (pumping chamber, reservoir, relief valve adjusting cap fitting, etc.) be sure that :

- Any pressure in the chamber has been completely vented through the suction or discharge lines or other appropriate openings or connections.
- The pump drive system means (motor, turbine, engine, etc.) has been "locked out" or otherwise been made non-operational so that it cannot be started while work is being done on the pump.
- You know what material the pump has been handling, have obtained a material safety data sheet (MSDS) for the material, and understand and follow all precautions appropriate for the safe handling of the material.

**WARNING**

**INSTALL** pressure gauges/sensors next to the pump suction and discharge connections to monitor pressures.



**WARNING**

**USE** extreme caution when lifting the pump. Suitable lifting devices should be used when appropriate. Lifting eyes installed on the pump must be used **only** to lift the pump, **not** the pump with drive and/or base plate. If the pump is mounted on a base plate, the base plate must be used for all lifting purposes. If slings are used for lifting, they must be safely and securely attached. For weight of the pump alone (which does not include the drive and/or base plate) refer to the Viking Pump product catalog.



**BEFORE** operating the pump, be sure all drive guards are in place.



**DO NOT** attempt to dismantle a pressure relief valve that has not had the spring pressure relieved or is mounted on a pump that is operating.



**DO NOT** operate pump if the suction or discharge piping is not connected.



**AVOID** contact with hot areas of the pump and/or drive. Certain operating conditions, temperature control devices (jackets, heat-tracing, etc.), improper installation, improper operation, and improper maintenance can all cause high temperatures on the pump and/or drive.



**DO NOT** place fingers into the pumping chamber or its connection ports or into any part of the drive train if there is **any possibility** of the pump shafts being rotated.



**WARNING**

**THE PUMP** must be provided with pressure protection. This may be provided through a relief valve mounted directly on the pump, an in-line pressure relief valve, a torque limiting device, or a rupture disk. If pump rotation may be reversed during operation, pressure protection must be provided on **both** sides of pump. Relief valve adjusting screw caps must always point towards suction side of the pump. If pump rotation is reversed, position of the relief valve must be changed. Pressure relief valves cannot be used to control pump flow or regulate discharge pressure. For additional information, refer to Viking Pump's Technical Service Manual TSM 000 and Engineering Service Bulletin ESB-31.

**WARNING**

**DO NOT** exceed the pumps rated pressure, speed, and temperature, or change the system/duty parameters from those the pump was originally supplied, without confirming its suitability for the new service.



**WARNING**

**BEFORE** operating the pump, be sure that:

- It is clean and free from debris
- all valves in the suction and discharge pipelines are fully opened.
- All piping connected to the pump is fully supported and correctly aligned with the pump.
- Pump rotation is correct for the desired direction of flow.



**WARNING**

**THE PUMP** must be installed in a matter that allows safe access for routine maintenance and for inspection during operation to check for leakage and monitor pump operation.

## SPECIAL INFORMATION

### DANGER !

Before opening any Viking pump liquid chamber (pumping chamber, reservoir, relief valve adjusting cap fitting etc.) Be sure:

1. That any pressure in the chamber has been completely vented through the suction or discharge lines or other appropriate openings or connections.
2. That the driving means (motor, turbine, engine, etc.) has been “locked out” or made non- operational so that it cannot be started while work is being done on pump.
3. That you know what liquid the pump has been handling and the precautions necessary to safely handle the liquid. Obtain a material safety data sheet (MSDS) for the liquid to be sure these precautions are understood.

Failure to follow above listed precautionary measures may result in serious injury or death.

**ROTATION:** Viking Mag Drive® pumps are designed to run in either direction. See **PUMP ROTATION**, page 11.

#### **PRESSURE RELIEF VALVES:**

1. Viking pumps are positive displacement pumps and must be provided with some sort of pressure protection. This may be a relief valve mounted directly on the pump, an inline pressure relief valve, a torque limiting device or a rupture disk. Do not rely on decoupling of magnets for protection from over pressure; this may result in damage to the magnets, pump, or other equipment.
2. Relief valves are mounted as standard on the casing of AS, AK,AL,KE and KKE size pumps.
3. If the pump rotation is to be reversed during operation, pressure protection must be provided on *both* sides of the pump.
4. The relief valve adjusting screw cap must always point towards the suction side of the pump. See **Figure 3**. If the pump rotation is reversed, remove the pressure relief valve and turn end for end (see **PUMP ROTATION**, page 11 for additional information.
5. Pressure relief valves cannot be used to control pump flow or regulate discharge pressure.

For additional information on pressure relief valves, refer to Technical Service Manual TSM000 and Engineering Service Bulletin ESB-31.

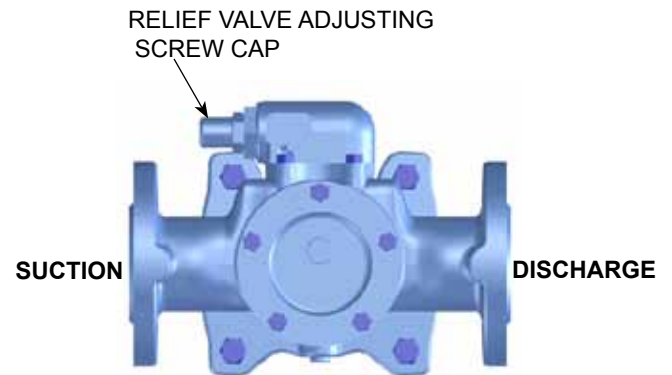

**FIGURE 3**  
**RELIEF VALVE POSITION**

### CAUTION !

Rare earth magnets used in these couplings have extremely strong magnetic fields capable of changing the performance or damaging items such as the following:

- Pacemakers
- Metal implants
- Watches
- Computers and discs
- Credit cards

**Completely assembled magnetic couplings will not affect the items listed above.**

**Altered performance or damage can occur only when the coupling halves are separated.**

**There are no known harmful effects of these magnetic fields on the human body itself.**

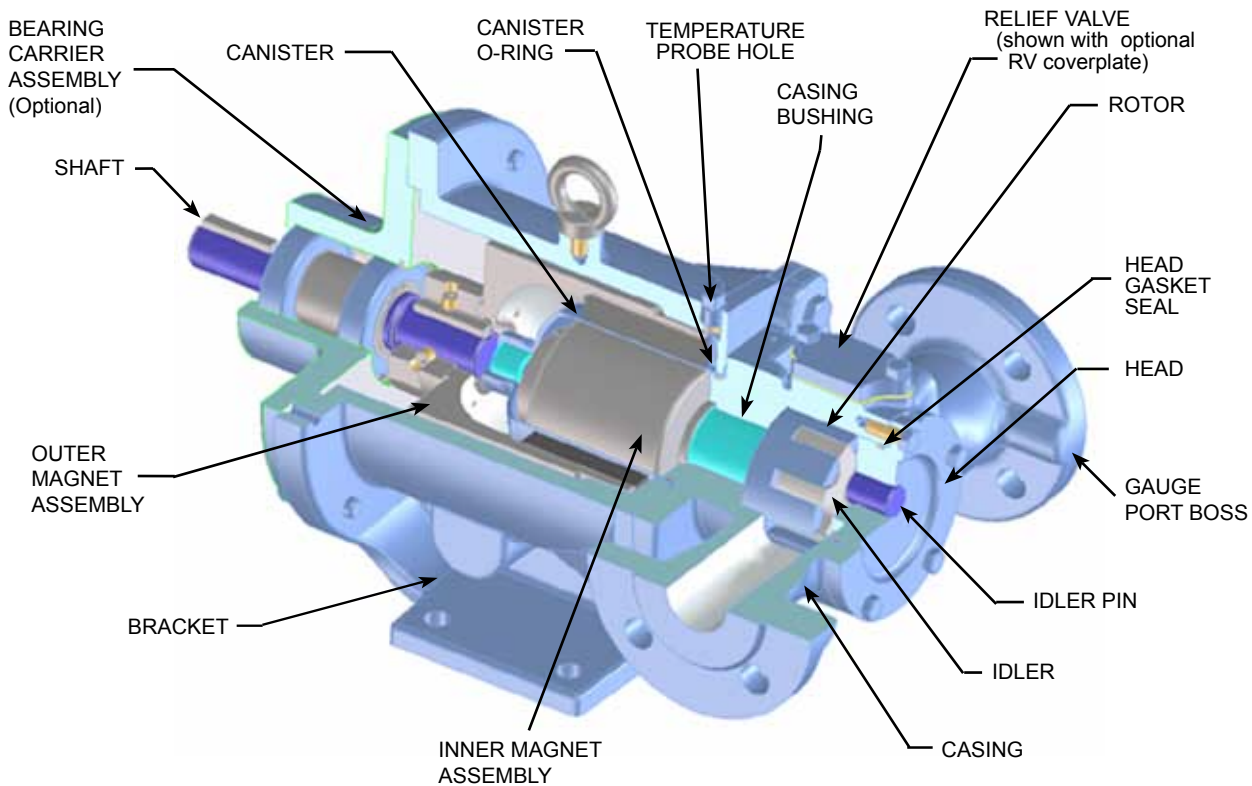

**FIGURE 4**

**CUTAWAY VIEW MAG DRIVE PUMP, MD2-B  
WITH BEARING CARRIER ILLUSTRATED**

## MAINTENANCE

Series 855 pumps are designed for long, trouble-free service life under a wide variety of application conditions with a minimum of maintenance. The points listed below will help provide long service life.

### **CLEANING PUMP:**

Keep the pump as clean as possible. This will facilitate inspection, adjustment and repair work.

### **LUBRICATION:**

Some bearing carriers require external lubrication. This must be applied slowly with a handgun to lubrication fittings every 500 hours of operation with multi-purpose grease, NLGI # 2. Do not over-grease. Applications involving very high or low temperatures will require other types of lubrication. Refer to ESB-515. Consult factory with specific lubrication questions.

### **STORAGE:**

If the pump and coupling are to be stored, drain the pump and pour non-detergent SAE 30-weight oil into the pump port. Apply grease to the pump or the coupling shaft extension, if present or accessible.

Viking suggests rotating the pump shaft every 30 days to circulate the oil in the pump. The coupling should be stored in a dry area.

**Note:** If the liquid to be pumped reacts with oil, use an acceptable alternate.

### **SUGGESTED REPAIR TOOLS:**

The following tools are required to properly repair Series 855 pumps. These tools are in addition to standard mechanics' tools such as open-end wrenches, pliers, screwdrivers, etc. Most of the items can be obtained from an industrial supply house.

1. Soft face hammer
2. Metric Allen wrenches (for set screws)
3. Torque Wrench with a locknut socket
4. External snap ring pliers - (Viking Part # 2-810-029-375)
5. Internal snap ring pliers - (Viking Part # 2-810-047-999)
6. Arbor press
7. Brass bar
8. Hook style spanner wrench

Series

AS855 M B-MD2 B14 B

**Size**  
(Nominal displacement)  
GS HJ AS KE  
GG HL AK KKE  
AL

**Material**  
5 = Cast Iron

**Port Design**  
M= DIN  
U= ANSI

**Coupling Size - Pump Related**  
A size = Used on GS, GG, HJ or HL  
B size = Used on HJ, HL, AS, AK or AL  
C Size = Used on AS, AK, AL, KE, or KKE

**Drive Configurations**  
M = Motor, Face Mount  
D = Direct Drive, Base Mounted  
B = Bearing Carrier  
R = Viking Reducer Drive  
P = Commercial Reducer Drive

**Magnetic Coupling Size and Torque Specification - Drive Related**  
A 4 and 9 Ft-Lbs  
B 14,32 and 50 Ft-Lbs  
C 40,90, 135 and 180 Ft-Lbs

**Magnetic Coupling Design**  
Second generation and not interchangeable with previous design.

FIGURE 5  
MODEL NUMBER SYSTEM

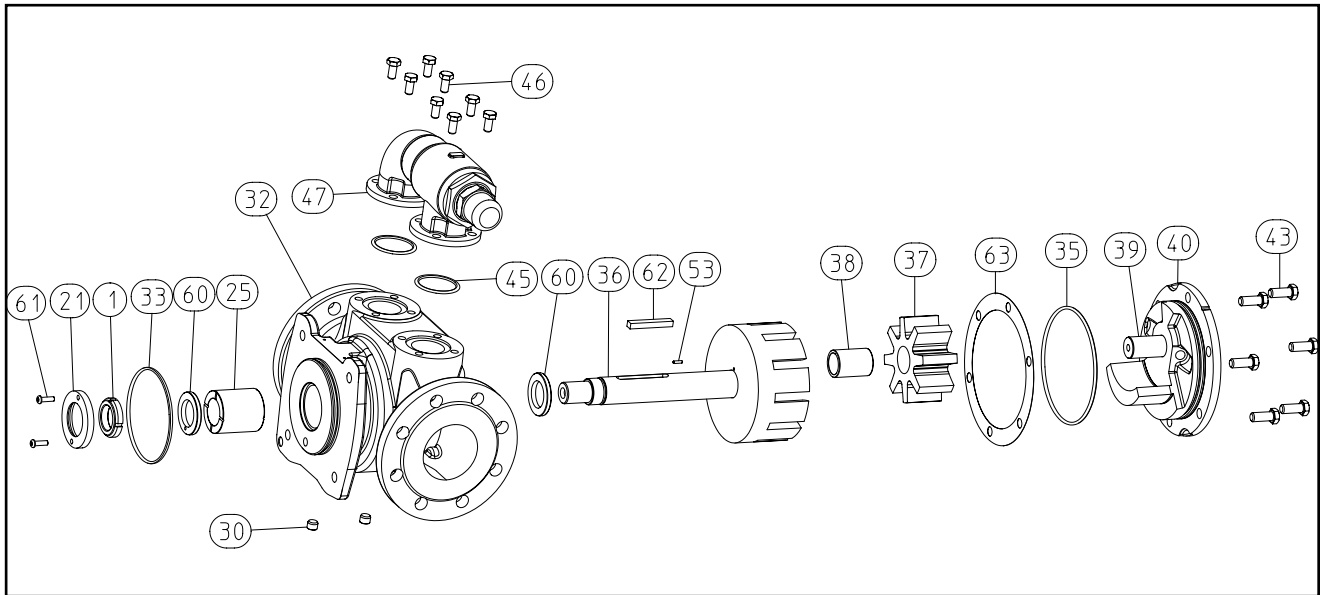

FIGURE 6  
EXPLODED VIEW – SIZES AS, AK, AL, KE & KKE MAG DRIVE PUMPS

ITEM	NAME OF PART	ITEM	NAME OF PART	ITEM	NAME OF PART
1	Locknut	36	Rotor and Shaft Assembly	46	Capscrews (metric) for Relief Valve - 6 Req'd
21	Set Collar	37	Idler	47	Relief Valve
25	Casing Bushing	38	Idler Bushing	53	Locating Pin
30	Pipe Plug - 2 Req'd	39	Idler Pin	60	Thrust Washer - 2 Req'd
32	Casing and Bushing Assembly	40	Head and Idler Pin Assembly	61	Machine Screws (metric) - 2 Req'd
33	Casing Stem O-ring	43	Capscrews (metric) for Head - 6 Req'd	62	Drive Key
35	Head O-ring	45	Relief Valve Gaskets - 2 Req'd	63	Shims for Head (metal)

TABLE 2

MAGNETIC COUPLING OPTIONS	
Pump Size	Magnetic Coupling Sizes
AS	B, C
AK	B, C
AL	B, C
KE	C
KKE	C

TORQUE RATINGS AND DRIVER CONNECTION OPTIONS				
Magnetic Coupling Sizes	Torque Ratings (Ft-Lbs)	Close-Coupled		Long-Coupled
		IEC B-5 Flange Motor Mounts	NEMA Motor Mounts	Bearing Carrier
B	• 14 • 32 • 50	• 100/112 • 132	• 182 / 184TC • 213 / 215TC • 254 / 256TC	Yes
C	• 40 • 90 • 135 • 180	• 132  • 160/180	• 213 / 215TC • 254 / 256TC • 284 / 286TC	Yes

**TABLE 3**  
**COUPLING TORQUE AND SIZE OPTIONS**

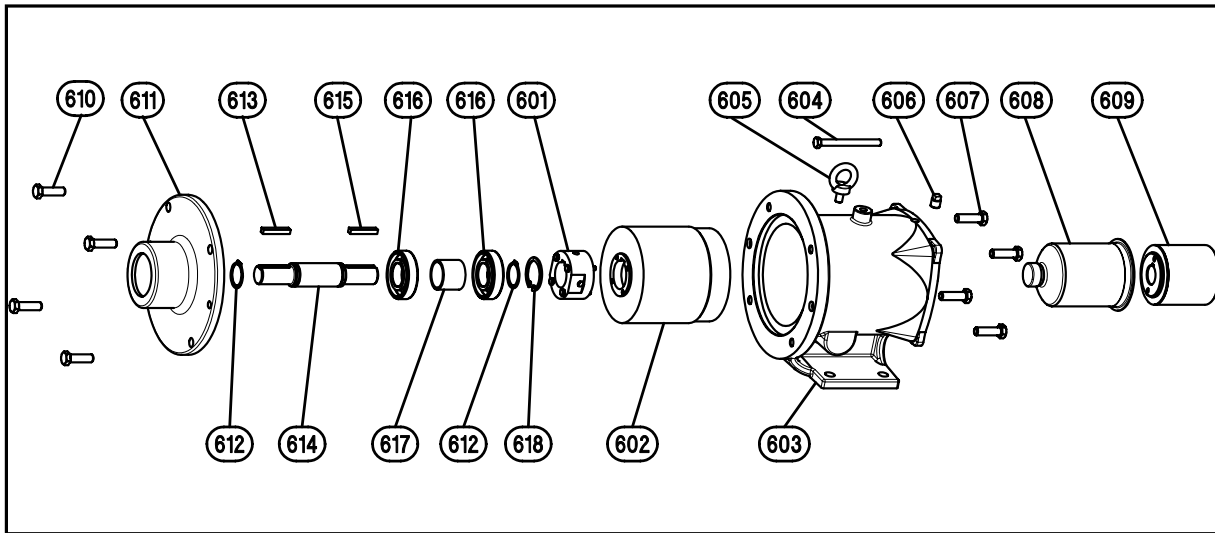

**FIGURE 7**  
**M DRIVE CONFIGURATION**  
**MD2- B SERIES COUPLING AND BEARING CARRIER COMPONENTS**

ITEM	DESCRIPTION	ITEM	DESCRIPTION	ITEM	DESCRIPTION
601	Bolt-on Hub with Hardware	607	Capscrews (metric) for Pump - 4 Req'd	613	Drive Key - Outboard Side
602	Outer Magnet Assembly	608	Canister and Bushing Assembly	614	Shaft
603	Bracket	609	Inner Magnet Assembly	615	Drive Key - Inboard Side
604	Capscrew (jackscrew) for Disassembly (metric)	610	Capscrews (metric) for Motor or Bearing Carrier - (4) Req'd	616	Ball Bearing - 2 Req'd
605	Lifting Eye	611	Bearing Carrier Housing	617	Spacer
606	Pipe Plug for Sensor Hole	612	External Retaining Ring - 2 Req'd	618	Internal Retaining Ring

**TABLE 4**

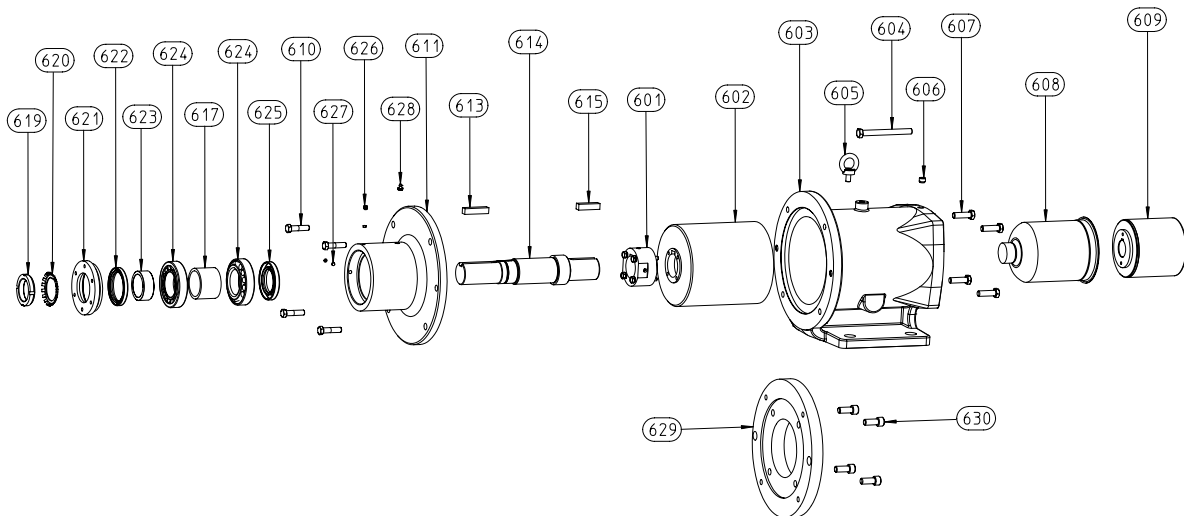

**FIGURE 8  
M DRIVE CONFIGURATION  
MD2- C SERIES COUPLING AND BEARING CARRIER COMPONENTS**

ITEM	DESCRIPTION	ITEM	DESCRIPTION	ITEM	DESCRIPTION
601	Bolt-on Hub with Hardware	611	Bearing Carrier Housing	623	Outer Bearing Spacer
602	Outer Magnet Assembly	613	Drive Key - Outboard Side	624	Tapered Roller Bearing - 2 Req'd
603	Bracket	614	Shaft	625	Lip Seal (Inner)
604	Capscrew (jackscrew) for Disassembly (metric)	615	Drive Key - Inboard Side	626	Setscrew - 2 Req'd
605	Lifting Eye	617	Inner Bearing Spacer	627	Insert - 2 Req'd
606	Pipe Plug for Sensor Hole	619	Locknut	628	Grease Fitting
607	Capscrews (metric) for Pump - 4 Req'd	620	Lockwasher	629	Adapter (NEMA motor only)
608	Canister and Bushing Assembly	621	End Cap	630	Capscrews (metric) for Adaptor - 4 Required
609	Inner Magnet Assembly	622	Lip Seal (Outer)		
610	Capscrews (metric) for Motor or Bearing Carrier - 4 Req'd (284 Motor Frame, - 5 req'd)				

**TABLE 5**

## PUMP DISASSEMBLY

### WARNING!

**Refer to DANGER & CAUTION listed on page 2 before proceeding.**

- To drain the liquid being pumped, remove the two (2) drain plugs located in the bottom of the casing. Once the liquid has drained replace the plugs.
  - Refer to Figures 4, 6, 7 & 8** for names of parts.
  - Mark the head and casing before disassembly to insure proper reassembly.
  - To inspect the head and pin assembly and idler and bushing assembly, remove the head capscrews.
  - Remove the head from the pump. Do not allow the idler to fall from the idler pin. Tilt the top of the pump head back when removing to prevent this. Avoid damaging the head shim set since all shims are required to maintain end clearance.
  - Remove the idler and bushing assembly. If the idler bushing needs to be replaced, see **"INSTALLATION OF BUSHINGS"** on page 10. If further disassembly is required, the pump must be separated from coupling. Refer to **"DISASSEMBLY OF COUPLING"** on page 8 before proceeding with Step 7.
  - With the inner magnet removed, now remove the pump shaft key. Remove the outer thrust washer. The rotor and shaft may now be removed by tapping on the end of the shaft with a soft face hammer (If a soft face hammer is not available a regular hammer may be used with a piece of hardwood).
  - Remove the inner thrust washer from behind the rotor.
- The casing should be examined for wear, particularly in the area between the ports. Clean all other parts thoroughly and examine for wear or damage. Check the bushings, idler pin and thrust washers; replace if necessary.
- When making major repairs, such as replacing a rotor and shaft, it is advisable to also install a new head and idler pin, idler and bushing, and casing bushings. See **"INSTALLATION OF BUSHINGS"** on page 10.

# DISASSEMBLY OF COUPLING

## Series MD2-B and MD2-C, All Sizes

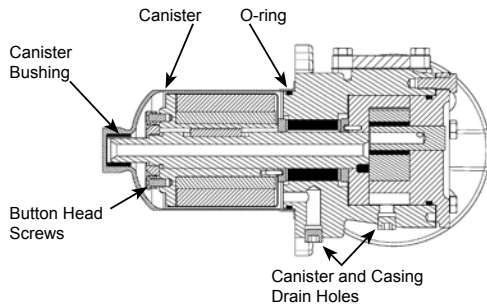

**FIGURE 9  
PUMP, INNER MAGNET AND CANISTER ASSEMBLY**

1. Remove the piping to the ports and remove the capscrews securing the pump to the bracket. Support the pump with an overhead hoist if possible. Use the M10 x 120 capscrew (jackscrew) in the bracket to separate the inner magnet from the outer. (See Figure Sequence 10).

### CAUTION !

Use extreme caution, when pulling the inner magnet away from the outer magnet (see Figure 10). Do not place your fingers between the pump mounting flange and the face of the bracket. If you do not completely pull the pump out it will snap back and could pinch a finger or hand. Once the inner magnet is removed from the bracket be careful setting it down as it will attract any iron or steel object.

2. The canister will contain some liquid, therefore use care while removing from the pump and pull it straight off.
3. Remove the two 6mm buttonhead machine screws and the set collar. Insert a brass bar through a port between two rotor teeth and remove the locknut (See Figure 11). Slide the inner magnet off the shaft. Do not forget this is a very strong magnet. If further pump disassembly is required, refer to Step 7 of **PUMP DISASSEMBLY**.
4. Do not remove the O-ring unless it is bad, especially if PTFE (derivative) encapsulated. If a new O-ring is required, follow instructions in the **ASSEMBLY** section on page 10.
5. You should be able to visually inspect the outer magnets from the end of the bracket. If removal is necessary, start by removing the (4) capscrews (See Figure 12) and separate the bracket from the motor or bearing carrier. Loosen the 2 setscrews on the outer shell hub and slide the outer magnet assembly off the shaft. If the unit features a bearing carrier, refer to Page 9 for disassembly of the bearing carrier housing.

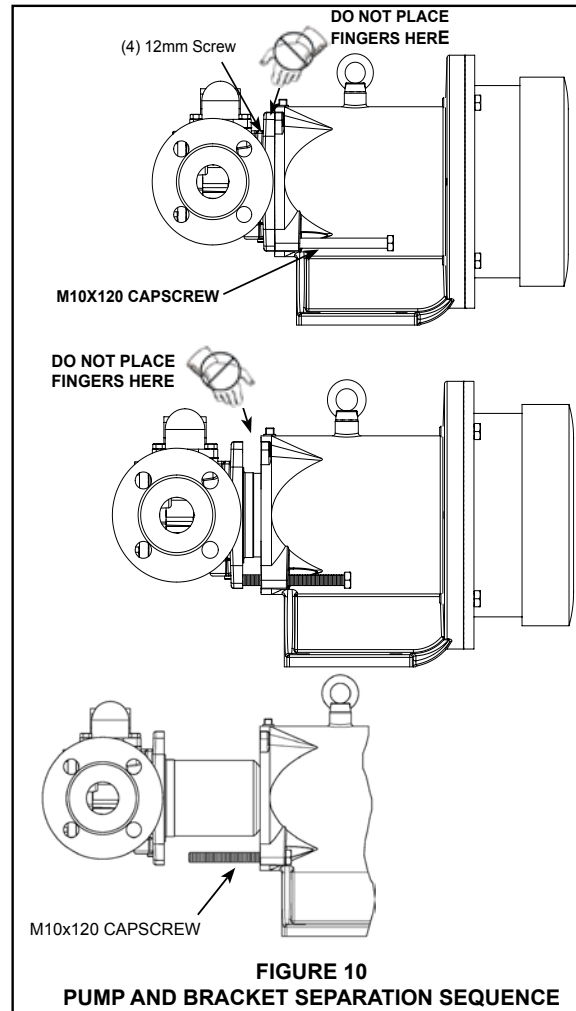

**FIGURE 10  
PUMP AND BRACKET SEPARATION SEQUENCE**

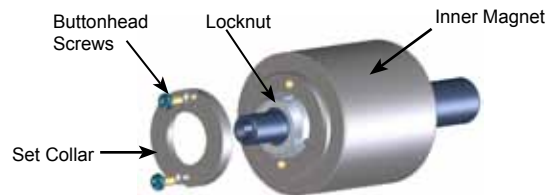

**FIGURE 11  
INNER MAGNET AND LOCKNUT ASSEMBLY**

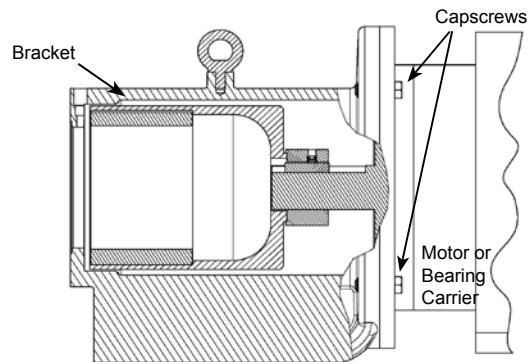

**FIGURE 12  
MOTOR (OR BEARING CARRIER) AND BRACKET**

# DISASSEMBLY / ASSEMBLY OF BEARING CARRIER

## Bearing Carrier for MD2-B Couplings

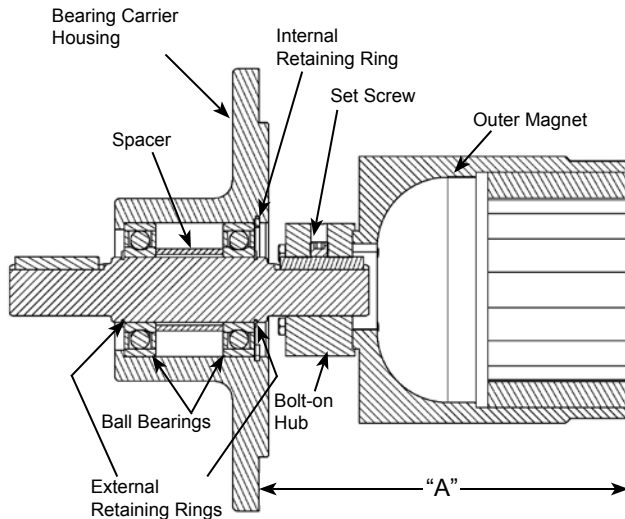

**FIGURE 13**  
**MD2-B OUTER MAGNET, BOLT ON HUB**  
**AND BEARING CARRIER**

### DISASSEMBLY

The bearing carrier for an MD2 B coupling features two sealed ball bearings along with the outer magnet assembly. If further disassembly of this unit is required, reference **Figure 7 on page 6 and Figure 13** then proceed as follows:

1. Remove the internal retaining ring. Using a press, press the shaft out of the housing.
2. Remove the external retaining rings from shaft. Place the unit into the press and push out shaft out of the bearings.

### ASSEMBLY

1. Place some Loctite® on the O.D. of the first bearing and press into the housing bore. Position the bearing spacer in the bore and insert the second bearing. Center the bearing spacer then press in the shaft with one external retaining ring on shaft. Press down until the ring contacts the bearing race, then install the second ring. Install the internal retaining ring into the bearing housing.
2. Slide the outer magnet assembly onto the pump shaft. Locate the outer magnet per dimension "A" listed below then tighten the two setscrews.

"B" Coupling Outer Magnet  
 Location Dimension\*

Pump Design	"A" Dim.
U.S. Inch Design	8.49 inches
Metric Design	220.4 mm

## Bearing Carrier for MD2-C Couplings

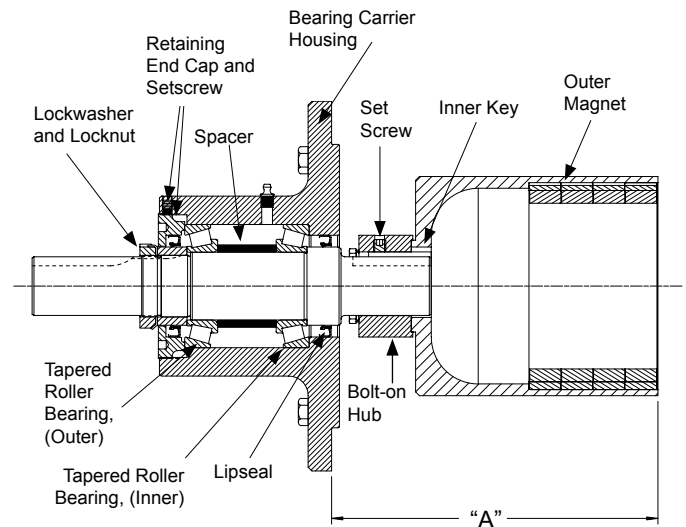

**FIGURE 14**  
**MD2-C OUTER MAGNET, BOLT ON HUB**  
**AND BEARING CARRIER**

### DISASSEMBLY

The bearing carrier for the MD2 C coupling features two tapered roller bearings secured by a threaded end cap. The unit is greased externally using the grease fitting. If further disassembly is required, reference **Figure 8 on page 7 and Figure 14**, then proceed as follows:

1. Remove the two setscrews from the bolt-on hub and slide the outer magnet off of the shaft. Remove the outboard drive key in shaft.
2. Place the inboard side of the shaft in a vise with padded jaws. Bend the lockwasher tab up and gently tap the locknut in a counterclockwise direction. Remove the locknut and lockwasher.
3. Loosen the two setscrews retaining the end cap. Back out the end cap completely. Pull or gently tap the shaft out the back of the bearing housing. Be sure to keep the cup and cone of the outer bearing together. If either the cup or cone requires replacing, it is recommended to replace as a set. The inner cone will probably stay in the housing unless it is to be replaced.
4. One lip seal is pressed into the end cap and the other is pressed into the bearing housing. Do not remove the lipseals unless they require replacement. If removed, pay close attention to the orientation as shown in **Figure 14** when installing the new lip seals.

\*Dimensions are not the same between designs

Loctite® is a trademark of Henkel Consumer Adhesives, Inc.

## Bearing Carrier for MD2-C Couplings (Cont.)

### ASSEMBLY

Depending on the condition of the bearings, either replace or repack existing bearings by cleaning and packing with multi-purpose NLGI # 2 grease. Replace the lip seals if necessary. See Figure 14, page 9 for lipseal orientation.

1. Place the bearing housing milled-face down with cast surface up. If the inner lip seal was removed, install with the cup up. Install the cup of inner bearing into housing (cup up).
2. Slide the inner tapered roller bearing cone onto the shaft (cone down) and then the inner spacer followed by the outer cone (cone up).
3. Guide shaft into the housing and into the inner lip seal. Slide the tapered roller bearing outer cup into the housing (cup down) and the bearing spacer collar onto shaft.
4. Thread in the end cap until it meets the outer cup. Install the lockwasher and locknut. Secure the end of the shaft in a vice with padded jaws then tighten the locknut. Tighten the end cap until there is considerable drag on the bearings, then back off the end cap approximately 10°. Secure the end cap into position by tightening the two set screws.
5. Tighten the locknut again, then bend over the appropriate lockwasher tab.
6. Install the inboard drive key, then slide the magnet onto the shaft. Locate the outer magnet per dimension "A" listed below. Tighten the two setscrews to lock into proper position.

"C" Coupling Outer Magnet  
Location Dimension

Pump Design	"A" Dim.
U.S. Inch Design	10.43 inches
Metric Design	265 mm

## INSTALLATION OF BUSHINGS

### CARBON GRAPHITE

The canister bushing (see Figure 9 on page 8) requires a special fixture for proper assembly so the bushing is only sold as part of the canister assembly.

If attempting to install the carbon graphite idler or casing bushing, extreme care must be taken to prevent breaking. Carbon graphite is a brittle material and easily cracked. If cracked, the bushing will quickly disintegrate. Using a lubricant on the bushing and mating part will help facilitate installation.

Figure 15 shows the proper position of the casing bushing after installation. This will require a special fixture for proper position. Improper location may result in a pump with excessive slip or requiring a large number of shims. The additional precautions listed below must be followed for installation:

1. An arbor press must be used for installation.
2. Be certain the bushing is started straight.
3. Do not stop the pressing operation until the bushing is in the proper position; starting and stopping will result in a cracked bushing.
4. After installation, check the bushing for cracks.

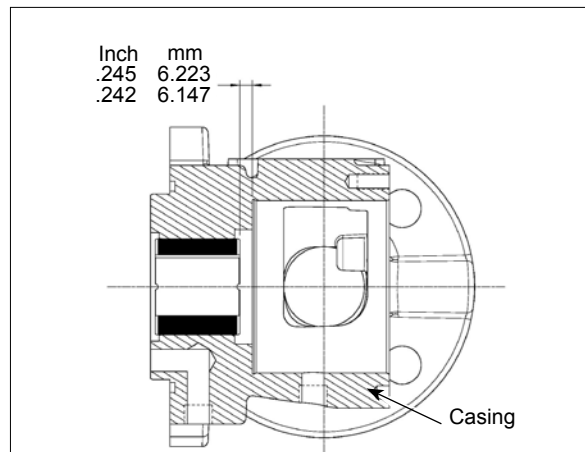

FIGURE 15  
CASING BUSHING POSITIONING

### ASSEMBLY OF PUMP

Use a suitable lubricant compatible with the fluid being handled when reassembling the pump.

Inspect all parts, especially drilled holes in the casing (for draining) to make sure they are not plugged. Replace any worn parts, remove any burrs, and clean all parts before assembling the pump.

1. If the canister O-ring needs to be replaced, apply a lubricant to the O-ring and place it into the O-ring groove. If the O-ring is PTFE (derivative) encapsulated, follow these special instructions.

**Do not** attempt to reuse a PTFE (derivative) encapsulated O-ring if it has been removed. Immerse a new O-ring in boiling water for a few minutes. Remove it from the water and stretch out the O-ring so it will fit onto the casing hub without forcing it over a sharp edge. Run hot water\* over the O-ring until it shrinks down tight onto the pilot of the pump. Dry with compressed air.

2. Clean the rotor and shaft so it is free of dirt, grit and other debris and apply lubricant. Place one thrust washer onto shaft so that the blind hole in thrust washer will line up with the drive pin on the back of the rotor. Push the rotor and shaft it into the casing as far as it will go.
3. Slide the second thrust washer onto the shaft, drive hole facing out and then install the key into the shaft.
4. Slide the inner magnet onto the shaft and engage the pin of the magnet into the hole of the thrust washer. Install the locknut, beveled edge out. Tighten the locknut to the torque value given in **Table 6**. Place a mark on the trailing edge of the locknut slot. Refer to Figure 16. Back off the locknut until the leading edge of that same slot lines up with the mark. This will establish the proper clearance for the thrust washers.
5. Place the set collar on the locknut and install the two machine screws.
6. If the old metal shims are not reusable or if any parts have been replaced, operating clearances will need to be re-established. Refer to **“ADJUSTING END CLEARANCE” on page 13**. Otherwise, place the head shims on the head. The proper amount of shims should be used to provide the correct end clearance. **Table 7** gives the quantity of shims available in a gasket set along with standard end clearance.

Locknut Torque Requirement		
	In-Lbs	N-m
MD2-B	60	6.8
MD2-C	80	9

**TABLE 6**

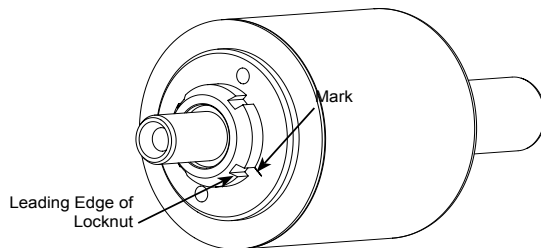

**FIGURE 16**

\*Hot water makes the PTFE more pliable and allows the inner elastomer to pull the PTFE back to the original size.

	<b>NORMAL<sup>1</sup> END CLEARANCE (inch)</b>	<b>SET OF HEAD SHIMS INCLUDES</b>
AS, AK, AL 855	0.005	(1) .007 (1) .005
KE, KKE 855	0.005	(2) .002 (2) .001

<sup>1</sup> End Clearances are adequate for viscosities up to 2500 SSU / 540 cSt (SAE 40 lube oil at room temperature). Higher viscosities require additional clearances. As a general rule the end clearance is doubled for higher viscosities. For specific recommendations for end clearance for viscosity or for operating temperatures above 225 °F (107 °C), check with your Viking representative or consult the factory.

**TABLE 7**

7. Coat the idler pin with a suitable lubricant and place the idler on the idler pin in head. Make sure the O-ring for the head is installed (In the O-ring is PTFE, follow instructions given in step 1).
  8. The head can now be assembled onto the pump. Tilt the top of the pump head away from the pump slightly until the crescent enters the inside diameter of the rotor and rotate the idler until its teeth mesh with the rotor teeth.
- The pump head and casing should have been marked before disassembly to insure proper reassembly. If not, be sure the idler pin, which is offset in the pump head, is placed in the 12 o'clock position from the port connections to allow for proper flow of liquid through the pump. Install the head capscrews. Rotate the shaft to make sure it turns freely.
9. Follow the instructions listed for assembling the appropriate size coupling on page 12.

## PUMP ROTATION

The pump is designed to operate in either direction. Process fluid is generally fed to the inner thrust washer and bushing interface and then through a groove in the bushing to the outer thrust washer. Then the fluid is pulled into the canister bushing and back through the hollow shaft and idler pin to the suction side of the pump. When the pump is operated in the opposite direction, the fluid flow is reversed.

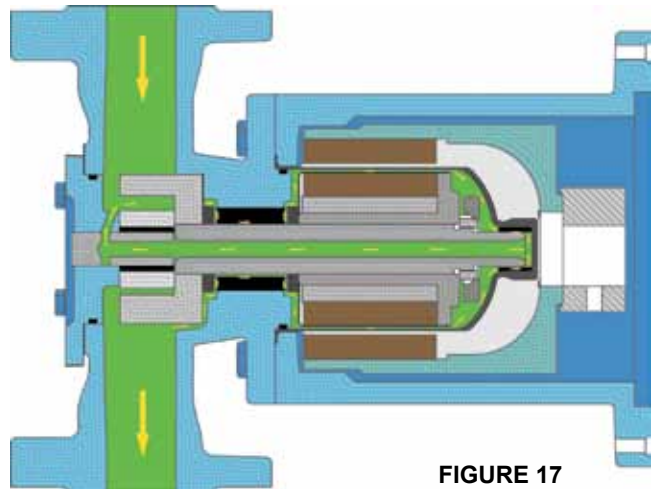

**FIGURE 17**

# ASSEMBLY OF COUPLING

## Series MD2-B and MD2-C, All Sizes

### DANGER !

Follow these directions exactly to avoid injury to self or damage to the pumping unit. Be careful to keep the inner and outer magnets at least (1) foot apart until step 4. Do not engage the magnets in any other fashion.

### CAUTION !

Do not place fingers onto the front of pump mounting flange. Align the canister into bore of the bracket and gently slide it in. When the magnets start to engage, the unit will finish engagement on its own very rapidly unless the M10x120mm capscrew is properly used. Make sure fingers are not on the front of the pump. See Figure Sequence 19.

### DANGER !

Before starting pump, be sure all drive equipment guards are in place. Failure to properly mount guards may result in serious injury or death.

1. Inspect the magnets for any steel objects, which may be attached. Remove any foreign material.

#### MD2-B Couplings:

Mount the outer magnet assembly. Locate the outer magnet assembly per dimension (See Figure 18).

#### MD2- C Couplings:

Units using a NEMA C-face frame motor will require an adaptor plate. Mount the adaptor plate to the motor if it was removed. Mount the outer magnet assembly. Locate the outer magnet assembly per dimension (See Figure 18).

Apply Loctite® and tighten the setscrews onto the motor or bearing carrier key and shaft.

2. If the bracket is not fastened to a base, clamp it down. Mount the motor or bearing carrier to the bracket. Reach in and rotate the magnets by hand to make sure there is no interference. If rubbing occurs check the dimension in Figure 18 or contact the factory.
3. Check to make sure the pump rotates freely by turning the inner magnet assembly. Inspect the magnet to make sure it has not picked up any foreign particles, which could damage the pump. Make sure the canister O-ring is in good condition and in place. Place the canister onto the pump and press on until the canister is in contact with the pump mounting flange.
4. Use a fully threaded M10X120mm capscrew (jackscrew) to guide the canister into the bracket. Thread the capscrew all the way into the bracket as shown in Figure Sequence 19. Use an overhead hoist to support the pump if possible while guiding the canister into the bracket opening.

Carefully back out the capscrew while guiding the canister into the bracket. Secure the pump to the bracket with four 12mm capscrews.

5. Be certain that the power supply to the pump is “Locked-out”. Check that pump rotates freely by spinning the motor fan blades or the bearing carrier shaft.

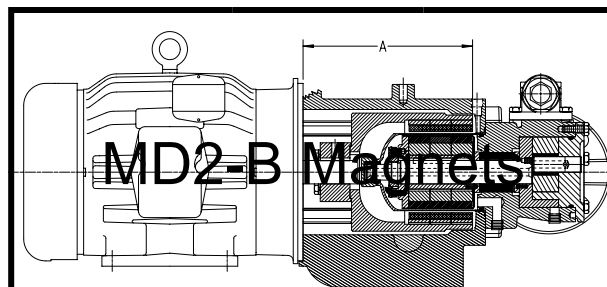

Dimensions are not the same between designs

Motor	“A” Dimension (Inch)	“A” Dimension (Metric)
I.E.C. 100/112	7.89	200.4 MM
I.E.C. 132	8.68	220.5 MM
182TC/184TC	8.11	206 MM
213TC/215TC	8.49	215.7 MM
254TC/256TC	9.11	231.5 MM

FIGURE 18

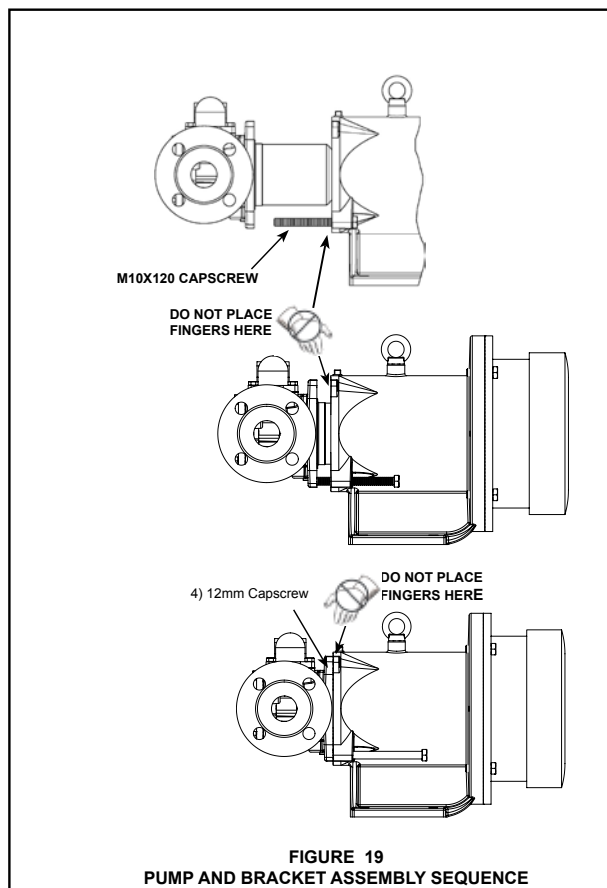

FIGURE 19  
PUMP AND BRACKET ASSEMBLY SEQUENCE

# ADJUSTING END CLEARANCE

Table 7-A provides standard operating end clearance for this pump. Use either of the following procedures to properly adjust the end clearance when replacing shims or reassembling the pump.

## PROCEDURE A

After the rotor has been installed and the locknut has been positioned and retained, insert a feeler gage of the proper end clearance thickness into the port at the root (base) of two rotor teeth (See Figure 20). For convenience, remove the head O-ring and install one 0.007" shim onto the head. With the idler on the idler pin, place the head into the pump casing. With the capscrews tight, the feeler gage should fit snugly between the idler and the rotor face; otherwise shims should be added or reduced in thickness until the proper clearance is attained.



FIGURE 20

## PROCEDURE B

If the pump is in line and ports are not accessible, remove the head and shims. Put the head back on (without shims) and measure the gap as shown (See Figure 21). After determining the gap between the head and casing, select a combination of shims equal to the measured gap plus the desired end clearance (See Figure 21). Remove head, install shims then install head. Tighten the head capscrews and check the pump clearance by making sure the pump turns freely by hand. Since the pump shaft is concealed, it is best to work up to the proper end clearance because it is difficult to determine when there is too much end clearance with this approach.

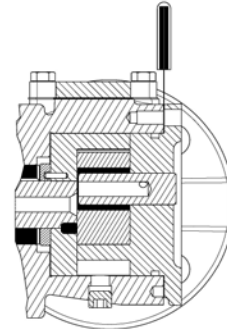

FIGURE 21

	NORMAL <sup>1</sup> END CLEARANCE (inch)	SET OF HEAD SHIMS INCLUDES
AS, AK, AL 855	0.005	(1) .007 (1) .005
KE, KKE 855	0.005	(2) .002 (2) .001

<sup>1</sup> End Clearances are adequate for viscosities up to 2500 SSU / 540 cSt (SAE 40 lube oil at room temperature). Higher viscosities require additional clearances. As a general rule the end clearance is doubled for higher viscosities. For specific recommendations for end clearance for viscosity or for operating temperatures above 225 °F (107 °C), check with your Viking representative or consult the factory.

TABLE 7-A

# PRESSURE RELIEF VALVE INSTRUCTIONS

## DANGER !

Before opening any Viking pump liquid chamber (pumping chamber, reservoir, relief valve adjusting cap fitting etc.) Be sure:

1. That any pressure in chamber has been completely vented through suction or discharge lines or other appropriate openings or connections.
2. That the driving means (motor, turbine,

engine, etc.) has been “locked out” or made non- operational so that it cannot be started while work is being done on pump.

3. That you know what liquid the pump has been handling and the precautions necessary to safely handle the liquid. Obtain a material safety data sheet (msds) for the liquid to be sure these precautions are understood.

Failure to follow above listed precautionary measures may result in serious injury or death.

## DISASSEMBLY – RELIEF VALVE

Mark the valve and head before disassembly to insure proper reassembly.

1. Remove the valve cap.
2. Measure and record the length of extension of the adjusting screw. Refer to "A" on **Figure 22**.
3. Loosen the locknut and back out the adjusting screw until spring pressure is released.
4. Remove the bonnet, spring guide, spring and poppet from the valve body. Clean and inspect all parts for wear or damage and replace as necessary.

## ASSEMBLY – RELIEF VALVE

Reverse the procedures outlined under **DISASSEMBLY – RELIEF VALVE**. If the valve is removed for repairs, be sure to replace in the original position. The relief valve adjusting screw cap must **always** point towards the suction side of the pump. If the pump rotation is reversed, remove the relief valve and turn end for end. **Refer to Figure 3, page 3.**

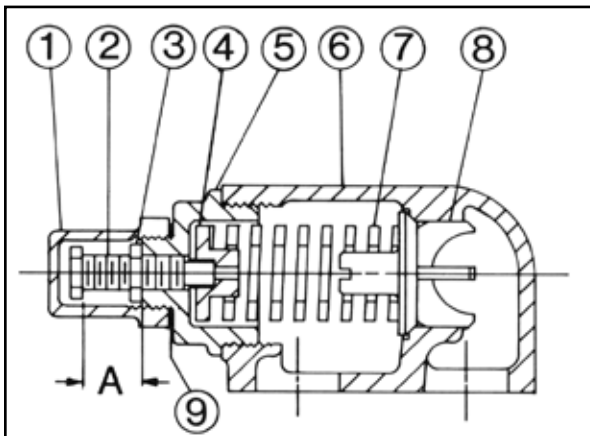

**FIGURE 22**  
**VALVE – AS, AK, AL, KE AND KKE SIZES**

VALVE - LIST OF PARTS	
1. Valve Cap	6. Valve Body
2. Adjusting Screw	7. Valve Spring
3. Lock Nut	8. Poppet
4. Spring Guide	9. Cap Gasket
5. Bonnet	

**TABLE 8**

## DANGER!

**Before starting pump, be sure all drive equipment guards are in place.**

**Failure to properly mount guards may result in serious injury or death.**

## PRESSURE ADJUSTMENT

If a new spring is installed or if the pressure setting of the pressure relief valve is to be changed from that which the factory has set, the following instructions must be carefully followed.

1. Carefully remove the valve cap, which covers the adjusting screw.
2. Loosen the locknut, which locks the adjusting screw so pressure setting will not change during operation of pump.
3. Install a pressure gauge in the discharge line for the actual adjustment operation.
4. Turn the adjusting screw in to increase pressure and out to decrease pressure.
5. With discharge line closed at a point beyond the pressure gauge, gauge will show the maximum pressure valve will allow while the pump is in operation.

## IMPORTANT

When ordering parts for the pressure relief valve, always give the model number and serial number of the pump as it appears on nameplate and name of the part wanted. When ordering springs, be sure to give pressure setting desired.

# TROUBLESHOOTING

Some of the following may help pinpoint the problem:

## **Pump does not pump:**

- Pump has lost its prime from air leak or low level in tank.
- Suction lift is too high.
- Pump is rotating in the wrong direction.
- The strainer may be clogged.
- The bypass valve is open, the pressure relief valve is set too low or the pressure relief valve poppet is stuck open.
- Improper end clearance.
- The pump is worn out.
- Are there any changes in liquid, system or operation that would influence pump or coupling performance, e.g. new liquid, additional lines or process changes?
- Temperature changes either in the liquid or the environment.
- The magnetic coupling is decoupling. Changes in application (temperature, pressure, viscosity, etc.) may require torque beyond coupling capabilities.

## **Pump starts, then loses its prime:**

- The supply tank is empty.
- Liquid is vaporizing in the suction line.
- An air leak or air pocket in the suction line.

## **Pump is noisy:**

- The pump is being starved (viscous liquid cannot get to pump fast enough). Increase the suction pipe size, reduce its length or slow down the pump.
- The pump is cavitating (liquid vaporizing in suction line). Increase suction pipe size or reduce its length.
- Check alignment.
- The magnetic coupling has decoupled. Shut off and restart.

## **Pump is not delivering up to capacity:**

- The pump is starving or cavitating - increase suction pipe size or reduce length or reduce pump speed.
- The strainer is partially clogged.
- An air leak somewhere in suction line.
- The pump may be running too slow. Is motor the correct speed and wired up correctly ?
- The pressure relief valve is set too low, stuck open or has a damaged poppet or seat.
- The bypass line around the pump is partially open.
- The pump is worn out or there is too much end clearance.

## **Pump takes too much power (stalls motor):**

- The liquid is more viscous than the unit is sized to handle.
- The system pressure relief valve is set too high.
- The bushings have frozen up or the liquid has set up in the pump.

**CAUTION !**

**TO REDUCE THE RISK OF LEAKAGE WITH VIKING MAG DRIVE PUMPS, USERS SHOULD COMPLY WITH THE FOLLOWING GUIDELINES AND ADHERE TO THE FOLLOWING PROCEDURES:**

- The pump configuration and materials used in a pump are tailored to the application for which it is ordered. Users should never use a pump for an application that is different from the application specified when the pump was ordered. This includes differences in liquid, speed, pressure, temperature or viscosity.
- Users must understand the characteristics of liquids they are pumping and be especially aware of any particulates in the liquid. Particulates can cause rapid wear of the bushings, especially if carbon graphite bushings are used. Hard bushings and hard shafts can reduce the risk of rapid wear, but the use of hard materials is not always the optimal solution. In applications involving non-abrasive, non-self lubricating liquids, carbon graphite bushings are typically the preferred material.
- Users should periodically inspect their pump for wear. This is especially critical and should be carried out with greater frequency when carbon graphite bushings are used or the same pump has not previously been used for the same application, including the same liquid, speed, pressure, temperature and viscosity. Users should promptly replace worn parts when they are discovered.
- Users should continuously monitor pumps that are handling hazardous liquids. This is especially critical for unmanned, remote locations. If a user does not have in-house expertise in the area of monitoring, it should contact a local engineering firm with monitoring experience.

**VIKING  
PUMP****IDEX  
CORPORATION****WARRANTY**

Viking warrants all products manufactured by it to be free from defects in workmanship or material for a period of one (1) year from date of startup, provided that in no event shall this warranty extend more than eighteen (18) months from the date of shipment from Viking. If, during said warranty period, any products sold by Viking prove to be defective in workmanship or material under normal use and service, and if such products are returned to Viking's factory at Cedar Falls, Iowa, transportation charges prepaid, and if the products are found by Viking to be defective in workmanship or material, they will be replaced or repaired free of charge, FOB. Cedar Falls, Iowa.

Viking assumes no liability for consequential damages of any kind and the purchaser by acceptance of delivery assumes all liability for the consequences of the use or misuse of Viking products by the purchaser, his employees or others. Viking will assume no field expense for service or parts unless authorized by it in advance.

Equipment and accessories purchased by Viking from outside sources which are incorporated into any Viking product are warranted only to the extent of and by the original manufacturer's warranty or guarantee, if any.

THIS IS VIKING'S SOLE WARRANTY AND IS IN LIEU OF ALL OTHER WARRANTIES, EXPRESSED OR IMPLIED, WHICH ARE HEREBY EXCLUDED, INCLUDING IN PARTICULAR ALL WARRANTIES OF MERCHANTABILITY OR FITNESS FOR A PARTICULAR PURPOSE. No officer or employee of IDEX Corporation or Viking Pump, Inc. is authorized to alter this warranty.