

CONTENTS

Introduction.....	1
Special Information.....	2
Lubrication.....	2
Installation.....	3
Operation.....	3
Disassembly.....	3
Assembly	
“A” Reducer.....	4
“B” Reducer.....	5
“C” Reducer.....	6
Technical Data.....	7
Warranty.....	8



FIGURE 1
“A” SIZE HELICAL GEAR REDUCER

INTRODUCTION

The illustrations used in this manual are for identification purposes only and cannot be used for ordering parts. Obtain a parts list from the factory or a Viking® representative. Always give the complete name of the repair part and part number along with the reducer part number when ordering repair parts. The reducer part number is stamped on the nameplate.

UNMOUNTED PUMP AND UNIT MODEL NUMBERS

“A”, “B” AND “C” SIZE REDUCERS		
SIZE	PART NUMBER	RATIO
A	3-551-049-224	2.24:1
	3-551-050-276	2.76:1
	3-551-051-343	3.43:1
	3-551-052-417	4.17:1
B	3-551-054-187	1.87:1
	3-551-055-224	2.24:1
	3-551-001-276	2.76:1
	3-551-002-340	3.40:1
	3-551-003-419	4.19:1
	3-551-004-506	5.06:1
	3-551-005-627	6.27:1
	3-551-007-765	7.65:1
C	3-551-056-221	2.21:1
	3-551-032-280	2.80:1
	3-551-008-331	3.31:1
	3-551-009-421	4.21:1
	3-551-010-508	5.08:1
	3-551-011-624	6.24:1
	3-551-012-795	7.95:1



FIGURE 2
“B” SIZE HELICAL GEAR REDUCER



FIGURE 3
“C” SIZE HELICAL GEAR REDUCER

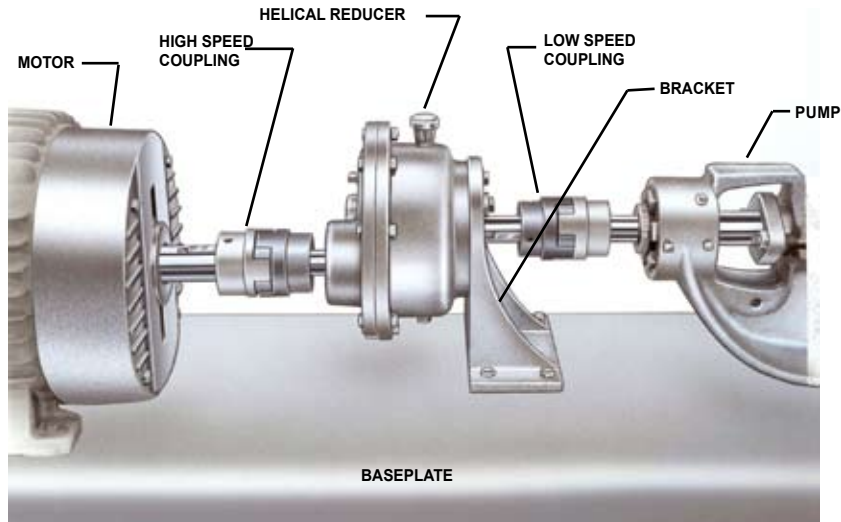

NOTE: UNIT FURNISHED WITH COUPLING GUARDS AS STANDARD

FIGURE 4
TYPICAL INSTALLATION

SPECIAL INFORMATION

DANGER !

Before opening any Viking pump liquid chamber (pumping chamber, reservoir, relief valve adjusting cap fitting etc.) , or drive equipment be sure:

1. That any pressure in the chamber has been completely vented through the suction or discharge lines or other appropriate openings or connections.
2. That the driving means (motor, turbine, engine, etc.) has been "locked out" or made non-operational so that it cannot be started while work is being done on pump.
3. That you know what liquid the pump has been handling or in the reducer and the precautions necessary to safely handle the liquid. Obtain a material safety data sheet (MSDS) for the liquid to be sure these precautions are understood.
4. Before starting unit or reducer, be sure all drive equipment guards are in place.

Failure to follow above listed precautionary measures may result in serious injury or death.

LUBRICATION

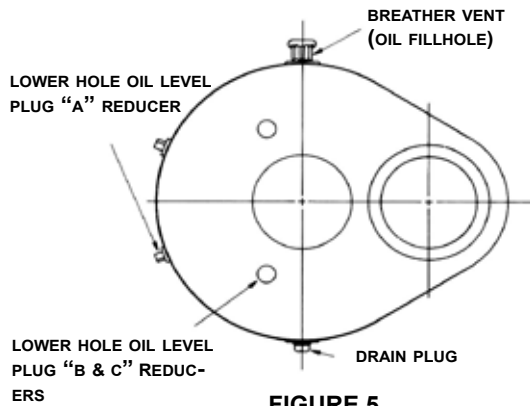

FIGURE 5

VIKING GEAR REDUCERS ARE SHIPPED WITHOUT OIL. BEFORE OPERATING THE REDUCER, BE SURE TO ADD THE PROPER AMOUNT AND TYPE OF LUBRICANT. CAUTION! DO NOT OVER FILL. See chart below.

REDUCER SIZE	QUANTITY	MOTOR OIL TYPE & SERVICE
A	3/8 PT. (6 OZ.)	Use SAE 30 Above 32°F Use SAE 10W Below 32°F
B	1/2 PT. (8 OZ.)	
C	2 & 1/4 PT. (36 OZ.)	

1. Remove the breather and add the proper lubricant for the type of service and quantity given after each size reducer.
2. After the first 100 hours of operation, drain and refill with new lubricant.
3. Check the lubricant level every 2000 hours of operation or every six months, which ever occurs first. Add lubricant as necessary.
4. Once each year drain and refill. If the reducer is outdoors, change to proper lubricant each spring and fall.

INSTALLATION

Viking helical gear reducers are shipped completely assembled and ready for installation *except for the addition of lubricant*.

1. Fasten the pump securely to the baseplate.
2. Mount the reducer on the reducer bracket finger tight. The breather cap should be located on the upper side of the reducer and drain plug on the bottom.
3. Place the coupling halves on the high and low speed reducer shafts.
4. Align the low speed shaft coupling half with the coupling half on the pump or driver shaft. Use a straight edge to align the coupling as in figure 6. A C-clamp, clamped over pieces of keystick, may be used to hold this alignment until the mounting bracket is securely bolted to the base plate. It may be necessary to shim the bracket to the exact center height of the pump or driven shaft. For additional information on coupling alignment, refer to Engineering Service Bulletin #ESB 61.

USE STRAIGHT EDGE. THESE SURFACES MUST BE PARALLEL

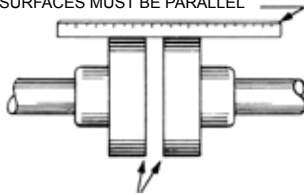

CHECK WIDTH BETWEEN THESE SURFACES WITH INSIDE CALIPERS TO BE CERTAIN THE FACES ARE EQUAL DISTANCE APART AND PARALLEL

FIGURE 6
COUPLING ALIGNMENT

5. Rotate the reducer in the "banana" slots of the bracket until the high speed coupling half is at the exact center height of the motor coupling half.
6. Securely tighten the reducer to the bracket .
7. Align the high speed shaft coupling and fasten the motor securely to base plate.

CAUTION! DO NOT EXCEED RECOMMENDED MAXIMUM HORSEPOWER, SEE CATALOG SPECIFICATION SHEET. DO NOT OPERATE BEFORE ADDING LUBRICANT.

OPERATION

After the first few hours of operation, inspect reducer for leaks. If leakage between gear case and cover cannot be stopped by tightening of nuts or capscrews, the gasket should be replaced. Leakage around either shaft indicates a damaged lip seal which should be replaced.

The operating temperature on the outside of the reducer case, after a few hours operation, should not be more than approximately 75° F higher than surrounding air temperature. The oil within the Reducer should never exceed 200° F.

Gear Ratios

Four different gear ratios are available for the "A" size Reducers. Eight ratios are available for "B" size reducers and seven ratios for "C" size reducers. Complete reducers within a size may be interchanged on a Viking pump unit to obtain desired pump speeds and capacities.

Gear ratios may be changed in all reducers within each size by selecting the proper pinion and gear of a common ratio. A pinion from one ratio cannot be used with a gear from a different ratio. Certain "B" and "C" reducers require additional or different parts besides the pinion and gear to make the ratio change. See the chart below for changes required.

SIZE	RATIO	CHANGES REQUIRED
B	6.27 to 1	Snap ring for pinion and shaft
	7.65 to 1	Two spacers (A larger O.D. than is used on other ratios) and gear shaft
C	7.95 to 1	Gear shaft and a longer key, also a snap ring.

NOTE: SNAP RING IS FURNISHED WITH "C" 7.95 TO 1 PINION AND SHAFT

When changing the reducer ratio, the nameplate should also be changed to new ratio reducer part number. After making any output or input speed change (complete reducer or gear ratio changes), a check should be made to ensure the couplings are of sufficient size for the conditions which reducer will be operating. For ratios available see page 1 of this manual, catalog specification sheet or consult factory or Viking representative.

DISASSEMBLY

Before starting disassembly, study the exploded view (see Fig. 7, 8 or 9) for the particular size reducer that is being disassembled to help determine parts relationship. The parts are indexed in a logical sequence of disassembly and will prove to be a valuable aid in dismantling the reducer.

1. Disconnect the couplings and remove the capscrews holding the mounting bracket to the base. Remove the coupling halves and bracket from the reducer.
2. Remove the breather and drain plugs. Drain all lubricant from the reducer.
3. Remove the capscrews from the gear case halves.
4. Tap firmly and alternately on the gear shaft and pinion shaft. This will separate the reducer halves.
5. With two screwdrivers at opposite sides, carefully pry the reducer cover loose from internal ball bearings. **DO NOT FORCE**. Be careful not to damage the gasket or gasket surface.
6. Grasp the pinion and gear shafts and pull both assemblies simultaneously from the case or cover.
7. Use a conventional gear or bearing puller to remove the bearing from gear shaft. Remove the bevelled spacer on "B" and "C" size reducers. Press the shaft from the gear.
8. Use a puller and remove bearings from the pinion shaft. Remove the spacer from "B" size 7.65 to 1 ratio from the pinion shaft.
9. Remove the lip seals from the gear case halves (cover and case) only if they show signs of deterioration or damage. Lip seals must be pressed or driven out from the inside of gear case and cover on "B" and "C" reducers. "A" size reducer may have lip seals pressed in or out from either side of gear case half.

ASSEMBLY

"A" Reducer Assembly - See Fig.7

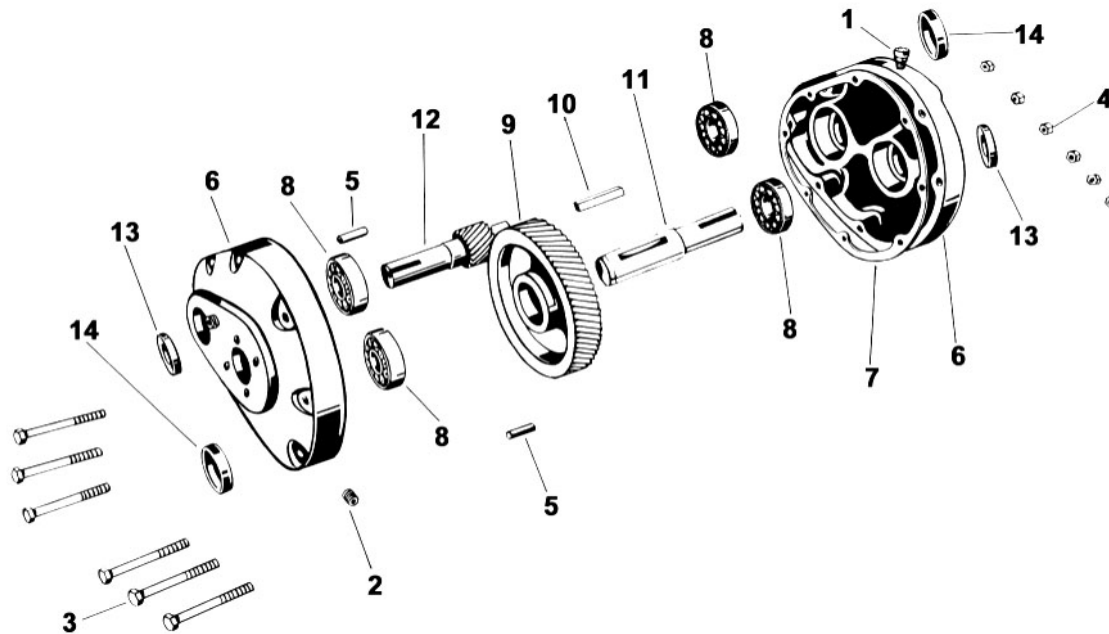

FIGURE 7
"A" SIZE HELICAL GEAR REDUCER - EXPLODED VIEW

ITEM	NAME OF PART	ITEM	NAME OF PART	ITEM	NAME OF PART
1	Breather	6	Gear Case Half (Set-2)	11	Gear Shaft
2	Pipe Plug (Set-3)	7	Gasket	12	Pinion & Shaft
3	Capscrew (Set-6)	8	Ball Bearing (Set-4)	13	Lip Seal (Set-2)
4	Nut (Set-6)	9	Gear	14	Cover (Set-2)
5	Dowel Pin (Set-2)	10	Key		

1. Install ball bearings on the pinion shaft. Be sure the single row bearings are seated firmly against the shoulders on the pinion shaft.
2. Install the square key in the gear shaft and press the gear into place.
3. Be sure the gear is centered on the shaft. Install the ball bearings on each side of the gear. Be sure the bearings are seated firmly against the gear and the shaft is still centered.
4. If the lip seal has been removed during disassembly, place the gear case halves, gasket faces down, on a surface which will not mar the face. Put gasket sealer on O.D. of lip seals. Drive new lip seals into the gear case halves (lip towards inside of reducer) with a wood block covering entire lip seal. Drive evenly until the lip seals are flush with the outer face of the gear case halves.
5. If steel covers have been removed during disassembly, install one cover in the bore of the gear case half opposite the pinion shaft extension. This cover should be flush with outer edge of case. Install a second cover in the bore of the gear case half, opposite the gear shaft extension .090 below the surface of the gear case. NOTE: Coat the side of the covers with sealer and drive the cover from the inside of case towards outside of case.
6. Apply lubricant to the lip seal sealing surfaces.
7. Block the gear case, open side up, to provide at least 2" clearance between the case and the assembly bench.
8. Make certain the pinion and gear shaft keyways are free of burrs and sharp edges to prevent damaging the sealing surfaces in the lip seals.
9. Take the pinion and gear assemblies, mesh the gear teeth and insert simultaneously into the gear case half. Rotate the gear shaft slightly as it is pushed through the lip seal. Tap the end of pinion shaft and gear shaft with a hard wood block to seat the bearings in the counterbores.
10. Place gasket on the gear case. If the gasket is damaged, discard it and use a new gasket.
11. Align the gear case half with ends of the pinion and gear shafts, and carefully pass the other half into place. Rotate the pinion shaft during assembly. Tap the gear case with a hard wood block to seat the bearings.
12. Install the six capscrews and nuts and tighten securely, alternating around gear case to prevent distortion.
13. Install drain plug. Be sure the proper amount and type of lubricant is added. See "Lubrication" instructions, page 2.

ASSEMBLY

"B" Reducer Assembly - See Fig. 8

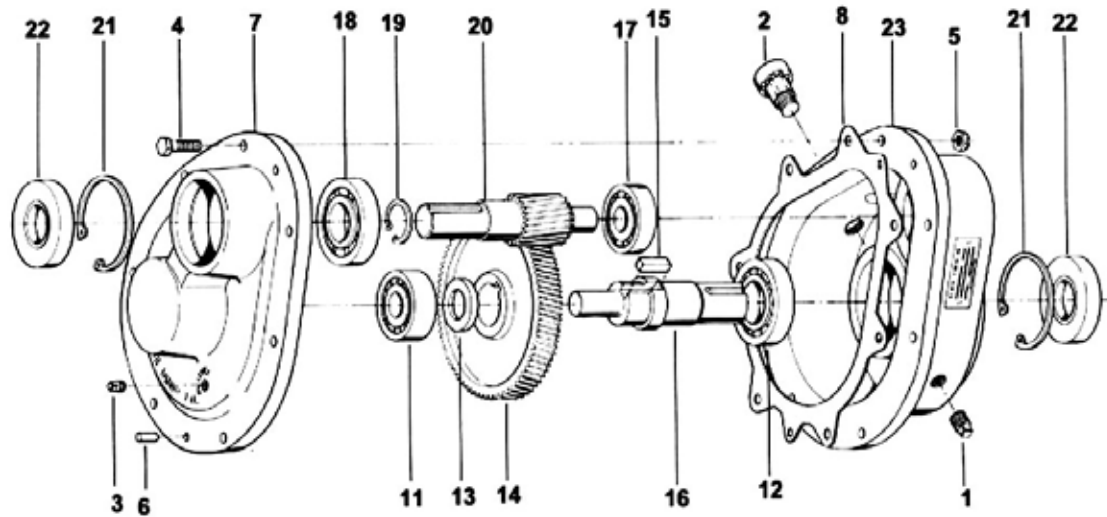

FIGURE 8
"B" SIZE HELICAL GEAR REDUCER - EXPLODED VIEW

ITEM	NAME OF PART	ITEM	NAME OF PART	ITEM	NAME OF PART
1	Drain Plug	11	Ball Bearing	19	Snap Ring (for 6.27 to 1 ratio only)
2	Breather	12	Ball Bearing	20	Pinion and Shaft
3	Pipe Plug (Set-2)	13	Spacer (7.65 to 1 Ratio - 2 Req'd)	21	Snap Ring (Set-2)
4	Capscrew (Set-7)	14	Gear	22	Lip Seal (Set-2)
5	Nut (Set-7) "B" only	15	Key	23	Gear Case
6	Dowel Pin Locating (Set-2)	16	Gear Shaft		
7	Gear Case Cover	17	Ball Bearing		
8	Gasket	18	Ball Bearing		

1. Install the ball bearing on the pinion and shaft. Be sure the bearings are seated firmly against the shoulders on the shaft.

NOTE: The "B" reducer with 6.27 to 1 ratio requires a snap ring. This snap ring must be installed in the groove on the shaft prior to bearing assembly. The bearing should be seated against the snap ring.

The "B" reducer with 7.65 to 1 ratio requires two spacers, one on the pinion and shaft and one on the gear shaft. The spacer for the pinion and shaft should be installed with bevelled edge toward bearing. Install the ball bearing on the pinion and shaft, seating the bearing firmly against the spacer.

2. Install the square key in the gear shaft and press the gear into place. Be sure the gear seats against the shoulder on the shaft.
3. Place the spacer on the gear shaft with the bevelled edge toward the gear. Install the bearing over the gear shaft and seat firmly against the spacer. Install a second bearing on the large end of the gear shaft and seat the bearing firmly against the shaft shoulder.
4. If the lip seals have removed during disassembly place the gear case and cover, gaskets face down, on a surface which will not mar the face. Be sure the snap rings are in the face and cover. Put gasket sealer on the O.D. of the

lip seals. Drive new lip seals with lip toward the inside of the reducer, in place against the snap rings. Use a wood block covering entire lip seal and drive evenly. Apply lubricant to lip seal surfaces.

5. Block the gear case, open side up, to provide at least 3¼" clearance between the case and the assembly bench.
6. Make certain the pinion and gear shaft keyways are free of burrs and sharp edges to prevent damaging the lip seal sealing surfaces. Take the pinion and gear assemblies, mesh the gear teeth, and insert simultaneously into the gear case half. Rotate the gear shaft slightly as it is pushed through lip seal. Tap end of the pinion shaft and gear shaft with hardwood block to seat the bearings in counter bores.
7. Place gasket on the gear case. If the gasket is damaged, discard it and use a new gasket.
8. Align the gear case cover with the ends of pinion and gear shafts, and carefully push the cover into place. Rotate the pinion shaft during assembly. Tap the cover with a hardwood block to seat the bearings in the cover.
9. Install the seven capscrews and nuts and tighten securely, alternating around gear case to prevent distortion.
10. Install the drain plug. Be sure the reducer is filled with the proper lubricant. See "Lubrication" instructions, page 2.

ASSEMBLY

"C" Reducer Assembly - See Fig. 9

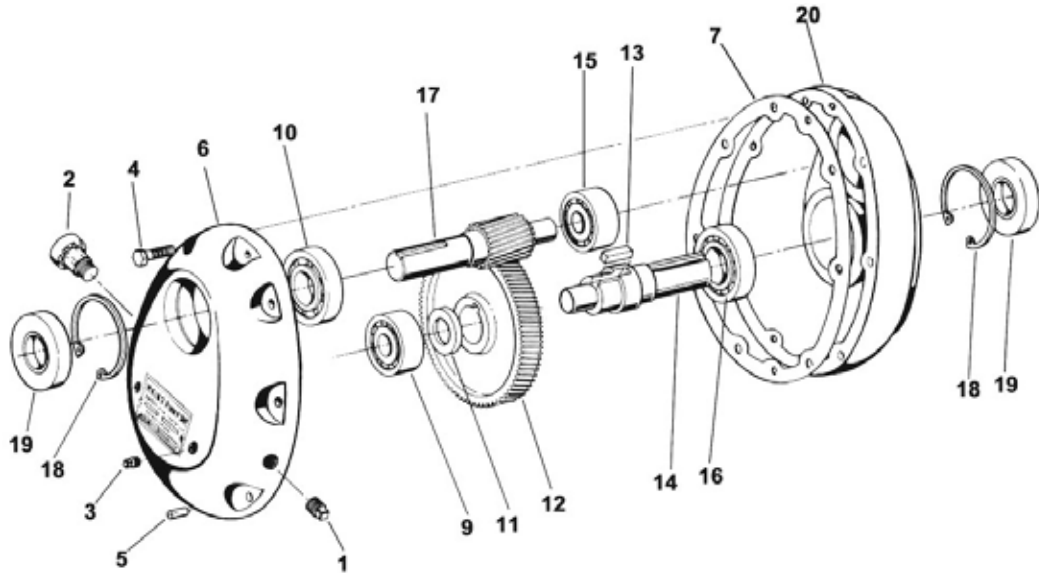

FIGURE 9
"C" SIZE HELICAL GEAR REDUCER - EXPLODED VIEW

ITEM	NAME OF PART	ITEM	NAME OF PART	ITEM	NAME OF PART
1	Drain Plug	7	Gasket	14	Gear Shaft
2	Breather	9	Ball Bearing (Double Row)	15	Ball Bearing (Double Row)
3	Pipe Plug (Set-2)	10	Ball Bearing (Single Row)	16	Ball Bearing (Single Row)
4	Capscrew (Set-2)	11	Spacer	17	Pinion and Shaft
5	Dowel Pin Locating (Set-2)	12	Gear	18	Snap Ring (Set-2)
6	Gear Case Cover	13	Key	19	Lip Seal (Set-2)

1. Install the ball bearing on the pinion shaft; the double row bearing on the small diameter end, and the single row bearing on the large diameter end. Be sure the bearings are seated firmly against the shoulders on the shaft.
NOTE: The pinion and shaft for "C" reducer (7.95 to 1 ratio) is furnished with a snap ring. This snap ring must be installed in the groove on the shaft prior to bearing assembly. The bearing should be seated against the snap ring.
2. Install the square key in the gear shaft and press the gear into place. Be sure the gear seats against the shoulder on the shaft.
3. Place the spacer on the gear shaft with beveled edge toward the gear. Install the bearing over gear shaft and seat firmly against the spacer. Install a second bearing on large end of the gear shaft and seat the bearing firmly against the shaft shoulder.
4. If the lip seals have been removed during disassembly place gear case and cover, gaskets face down, on surface which will not mar the face. Be sure the snap rings are in the face and cover. Put gasket sealer on the O.D. of lip seals. Drive new lip seals with lip toward the inside of the reducer, in place against the snap rings. Use a wood block covering entire lip seal and drive evenly. Apply lubricant to lip seal surfaces.
5. Block the gear case, open side up, to provide at least 3/4" clearance between case and assembly bench.
6. Make certain the pinion and gear shaft keyways are free of burrs and sharp edges to prevent damaging the lip seal sealing surfaces. Take the pinion and gear assemblies, mesh the gear teeth, and insert simultaneously into the gear case half. Rotate the gear shaft slightly as it is pushed through the lip seal. Tap the end of the pinion shaft and gear shaft with hardwood block to seat the bearings in the counter bores.
7. Place the gasket on gear case. If the gasket is damaged, discard it and use a new gasket.
8. Align the gear case cover with the ends of the pinion and gear shafts, and carefully push the cover into place. Rotate the pinion shaft during assembly. Tap the cover with a hardwood block to seat the bearings in cover.
9. Install the seven capscrews and nuts and tighten securely, alternating around the gear case to prevent distortion.
10. Install the drain plug. Be sure the reducer is filled with proper lubricant. See "Lubrication" instructions, page 2.

SELECTING THE CORRECT VIKING HELICAL GEAR REDUCER

1. Determine ratio to obtain desired output speed.
 2. Determine actual horsepower requirements of application.
 3. Determine equivalent horsepower for the application by multiplying the actual horsepower to be transmitted by the appropriate service factors, which can be obtained in the Service Factor Table below.
 4. Refer to the recommended maximum reducer horsepower line in the horsepower tables below and make sure the equivalent horsepower for a given input speed and ratio is less than or equivalent to the maximum recommended horsepower shown in the chart.
- This service factor takes into account the time length of service per day, the load classification (uniform, moderate shock, heavy shock), and the type of drive.

Service Factor Table

POWER SOURCE ^{(1) (3)}	CHARACTER OF DRIVEN LOAD ^{(2) (3)}	INTERMITTENT UP TO 3 HRS. A DAY	8-10 HRS. A DAY	24 HRS. A DAY
Electric Motor, Steam Turbine, or Hydraulic Motor	Uniform	.8	1.0	1.25
	Moderate Shock	1.0	1.25	1.5
	Heavy Shock	1.5	1.75	2.0
Multi-Cylinder Internal Combustion Engine	Uniform	1.0	1.25	1.5
	Moderate Shock	1.25	1.5	1.75
	Heavy Shock	1.75	2.0	2.25

1. For applications driven by single cylinder engines, refer to factory for other service factors.
2. Rotary pump applications are considered as uniform loads.
3. Use of belt or chain type drives to either reducer input or output shaft is not recommended.

“A” Size Helical Reducer Horsepower Table

Part No./Ratio (3-551-049-224/2.24:1) (3-551-050-276/2.76:1) (3-551-051-343/3.43:1) (3-551-052-417/4.17:1)

HIGH SPEED SHAFT INPUT RPM ⁽¹⁾	VIKING GEAR REDUCER RATIOS “A” SIZE				
	2.24:1	2.76:1	3.43:1	4.17:1	
1750	780	640	520	420	LOW SPEED SHAFT RPM
	6.1	4.9	3.8	3.1	MAXIMUM REDUCER HP
1450	640	520	420	350	LOW SPEED SHAFT RPM
	5.2	4.2	3.2	2.7	MAXIMUM REDUCER HP
1150	520	420	350	280	LOW SPEED SHAFT RPM
	4.3	3.4	2.6	2.2	MAXIMUM REDUCER HP
950	420	350	280	230	LOW SPEED SHAFT RPM
	3.6	2.9	2.2	1.8	MAXIMUM REDUCER HP

1 For input speeds higher than 1750 RPM, consult the factory.

“B” Size Helical Reducer Horsepower Table

Part No./Ratio (3-551-054-187/1.87:1) (3-551-055-224/2.24:1) (3-551-001-276/2.76:1) (3-551-002-340/3.40:1) (3-551-003-419/4.19:1) (3-551-004-506/5.06:1) (3-551-005-627/6.27:1) (3-551-007-765/7.65:1)

HIGH SPEED SHAFT INPUT RPM ⁽¹⁾	VIKING GEAR REDUCER RATIOS “B” SIZE								
	1.87:1	2.24:1	2.76:1	3.40:1	4.19:1	5.06:1	6.27:1	7.65:1	
1750	950	780	640	520	420	350	280	230	LOW SPEED SHAFT RPM
	19.0	17.0	15.0	13.0	11.0	9.5	7.6	6.4	MAXIMUM REDUCER HP
1450	780	640	520	420	350	280	230	190	LOW SPEED SHAFT RPM
	17.3	15.5	13.4	11.6	9.9	8.5	6.4	5.4	MAXIMUM REDUCER HP
1150	640	520	420	350	280	230	190	155	LOW SPEED SHAFT RPM
	16.5	14.0	11.6	10.1	8.5	7.3	5.3	4.4	MAXIMUM REDUCER HP
950	520	420	350	280	230	190	155	125	LOW SPEED SHAFT RPM
	15.5	12.8	10.1	9.0	7.6	6.0	4.3	3.7	MAXIMUM REDUCER HP

1 For input speeds higher than 1750 RPM, consult the factory.



TECHNICAL SERVICE MANUAL

VIKING® HELICAL GEAR REDUCERS “A”, “B”, AND “C” SIZES

SECTION	TSM 610
PAGE	8
ISSUE	F

“C” Size Helical Reducer Horsepower Table

Part No./Ratio (3-551-056-221/2.21:1) (3-551-008-331/3.31:1) (3-551- 009-421/4.21:1) (3-551-010-508/5.08:1)
(3-551-011-624/6.24:1) (3-551-012-795/7.95:1) (3-551-032-280/2.80:1)

HIGH SPEED SHAFT INPUT RPM ⁽¹⁾	VIKING GEAR REDUCER RATIOS “C” SIZE							
	2.21:1	2.80:1	3.31:1	4.21:1	5.80:1	6.24:1	7.95:1	
1750	780	640	520	420	350	280	220	LOW SPEED SHAFT RPM
	49.8	43.5	39.0	32.4	26.6	19.7	18.0	MAXIMUM REDUCER HP
1450	640	520	420	350	280	230	180	LOW SPEED SHAFT RPM
	45.3	36.6	32.8	27.2	22.3	16.7	15.2	MAXIMUM REDUCER HP
1150	520	420	350	280	230	190	145	LOW SPEED SHAFT RPM
	40.1	30.0	26.8	22.2	18.2	13.8	12.6	MAXIMUM REDUCER HP
950	420	350	280	230	190	155	120	LOW SPEED SHAFT RPM
	29.1	24.7	22.1	18.3	15.0	11.4	10.4	MAXIMUM REDUCER HP

¹ For input speeds higher than 1750 RPM, consult the factory.



WARRANTY

Viking warrants all products manufactured by it to be free from defects in workmanship or material for a period of one (1) year from date of startup, provided that in no event shall this warranty extend more than eighteen (18) months from the date of shipment from Viking. If, during said warranty period, any products sold by Viking prove to be defective in workmanship or material under normal use and service, and if such products are returned to Viking's factory at Cedar Falls, Iowa, transportation charges prepaid, and if the products are found by Viking to be defective in workmanship or material, they will be replaced or repaired free of charge, FOB. Cedar Falls, Iowa.

Viking assumes no liability for consequential damages of any kind and the purchaser by acceptance of delivery assumes all liability for the consequences of the use or misuse of Viking products by the purchaser, his employees or others. Viking will assume no field expense for service or parts unless authorized by it in advance.

Equipment and accessories purchased by Viking from outside sources which are incorporated into any Viking product are warranted only to the extent of and by the original manufacturer's warranty or guarantee, if any.

THIS IS VIKING'S SOLE WARRANTY AND IS IN LIEU OF ALL OTHER WARRANTIES, EXPRESSED OR IMPLIED, WHICH ARE HEREBY EXCLUDED, INCLUDING IN PARTICULAR ALL WARRANTIES OF MERCHANTABILITY OR FITNESS FOR A PARTICULAR PURPOSE. No officer or employee of IDEX Corporation or Viking Pump, Inc. is authorized to alter this warranty.