



# TECHNICAL SERVICE MANUAL

**HEAVY DUTY PUMPS  
SERIES 335 AND 4335  
SIZES N, R, AND P**

SECTION	TSM 143
PAGE	1 OF 15
ISSUE	D

## CONTENTS

Introduction	1
Special Information	2
Maintenance	2
Packed Pumps	4
Mechanical Seal Pumps	8
Optional PTFE Seal	12
Thrust Bearing Adjustment	13
Installation of Carbon Graphite Bushings	13
Pressure Relief Valve Instructions	14
Warranty	15



FIGURE 1

## INTRODUCTION

The illustrations used in this manual are for identification purposes only and cannot be used for ordering parts. Obtain a parts list from the factory or a Viking® representative. Always give the complete name of the part, part number and material with the model number and serial number of the pump when ordering repair parts. The unmounted pump or pump unit model number and serial number are on the nameplate.

In the Viking model number system, basic size letters are combined with the series number (335 and 4335) indicating both unmounted or mounted pump unit.

### MODEL NUMBER CHART

UNMOUNTED PUMP		UNITS
PACKED	MECH. SEAL	Units are designated by the unmounted pump model numbers followed by a letter indicating drive style. P = Commercial Speed Reducers
N335	N4335	
R335	R4335	
P335	P4335	

This manual deals only with Series 335 and 4335 Heavy-Duty Pumps. Refer to Figures 1 through 20 for general configuration and nomenclature used in this manual. Pump specifications and recommendations are listed in Catalog Section 143, for series 335 and 4335 Heavy-Duty Pumps.

### DANGER !

**Before opening any Viking pump liquid chamber (pumping chamber, reservoir, relief valve adjusting cap fitting etc.) be sure:**

1. That any pressure in chamber has been completely vented through the suction or discharge lines or other appropriate openings or connections.
2. That the driving means (motor, turbine, engine, etc.) has been "locked out" or made non-operational so that it cannot be started while work is being done on the pump.
3. That you know what liquid the pump has been handling and the precautions necessary to safely handle the liquid. Obtain a material safety data sheet (msds) for the liquid to be sure these precautions are understood.

**Failure to follow the above listed precautionary measures may result in serious injury or death.**

## SPECIAL INFORMATION

**ROTATION:** Viking pumps operate equally well in a clockwise or counterclockwise rotation. Shaft rotation determines which port is suction and which is discharge. The suction port location is where pumping elements (gear teeth) come out of mesh.

**CIRCULATION LINES:** are standard equipment (N & R size only) and must be properly connected. Packed pumps have a line connected from the packing chamber to the discharge port. Mechanical seal pumps have a line connected from the seal chamber to the suction port. If the pump rotation is reversed be sure the circulation lines are connected to the suction or discharge port as noted above to avoid excessive leakage or damage to pump. If the pump is handling heated product be sure the circulation line is insulated to assure continued flow.

The jacketed head (R & P only, optional on N size) and rotor bearing sleeve provide large chambers at both ends of the pumping chamber for temperature control of product in the pump. These features do not alter basic steps in the disassembly and assembly of your pump.

### **PRESSURE RELIEF VALVES:**

1. Viking pumps are positive placement pumps and must be provided with some sort of pressure protection. This may be a relief valve mounted directly on the pump, an inline pressure relief valve, a torque limiting device or a rupture disk.
2. A non-jacketed relief valve is standard on these pumps. Options include plain and jacketed relief valves. N size pumps with a jacketed head with a relief valve is not available. R size pumps are standard with a jacketed head but also have both plain and jacketed relief valve available as options. P size pumps are standard with a jacketed head and non-jacketed relief valve.
3. If the pump rotation is to be reversed during operation, pressure protection must be provided on *both* sides of pump.
4. The relief valve adjusting screw cap must always point towards suction side of pump. If pump rotation is reversed, remove the pressure relief valve and turn end for end. Refer to Figure 2.
5. Pressure relief valves cannot be used to control the pump flow or regulate the discharge pressure.

For additional information on pressure relief valves, refer to Technical Service Manual TSM000 and Engineering Service Bulletin ESB-31.

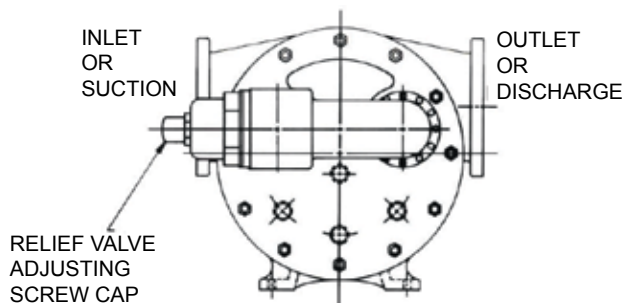

FIGURE 2

**SPECIAL MECHANICAL SEALS:** can be installed in a modified stuffing box.

Extra care must be taken in the repair of pumps with mechanical seals. Read and follow all special information supplied with the pump.

## MAINTENANCE

The Series 335 and 4335 pumps are designed for long trouble free life under a wide variety of application conditions with a minimum of maintenance. The points listed below will help provide long service life.

**LUBRICATION:** External lubrication must be applied slowly with a handgun to all lubrication fittings every 500 hours of operation with multi-purpose grease, NLGI # 2. Do not over-grease. Applications involving very high or low temperatures will require other types of lubrication. **Refer to Engineering Service Bulletin ESB-515.** Consult factory with specific lubrication questions.

**PACKING ADJUSTMENT:** New packed pumps require an initial packing adjustment to control leakage as the packing "runs in". Make initial adjustments carefully and do not over-tighten the packing gland. After the initial adjustment, inspection will reveal the need for packing gland adjustment or packing replacement. **Refer to instructions under DISASSEMBLY, page 4, and ASSEMBLY, page 6,** regarding repacking the pump.

**CLEANING PUMP:** Keep the pump as clean as possible. This will facilitate inspection; adjustment and repair work and help prevent overlooking a dirt covered grease fitting.

**STORAGE:** If the pump is to be stored, or not used for six months or more, the pump must be drained and a light coat of non-detergent SAE 30 weight oil must be applied to all internal pump parts. Lubricate fittings and apply grease to the pump shaft extension. Viking suggests rotating the pump shaft by hand one complete revolution every 30 days to circulate the oil.

**SUGGESTED REPAIR TOOLS:** The following tools must be available to properly repair Series 335 and 4335 pumps. These tools are in addition to standard mechanics' tools such as open end wrenches, pliers, screwdrivers etc. Most of the listed items can be obtained from an industrial supply house.

1. Soft Headed Hammer
2. Allen Wrenches (for some mechanical seals and set collars)
3. Packing hooks, flexible (packed pumps)  
Large for 0.375 inch and up cross section packing
4. Bearing locknut spanner wrench  
(Source: #471 J.H. Williams & Co. or equal)
5. Spanner wrench (Supplied with pump)  
Viking Part Number 3-810-009-631
6. Brass Bar
7. Arbor Press

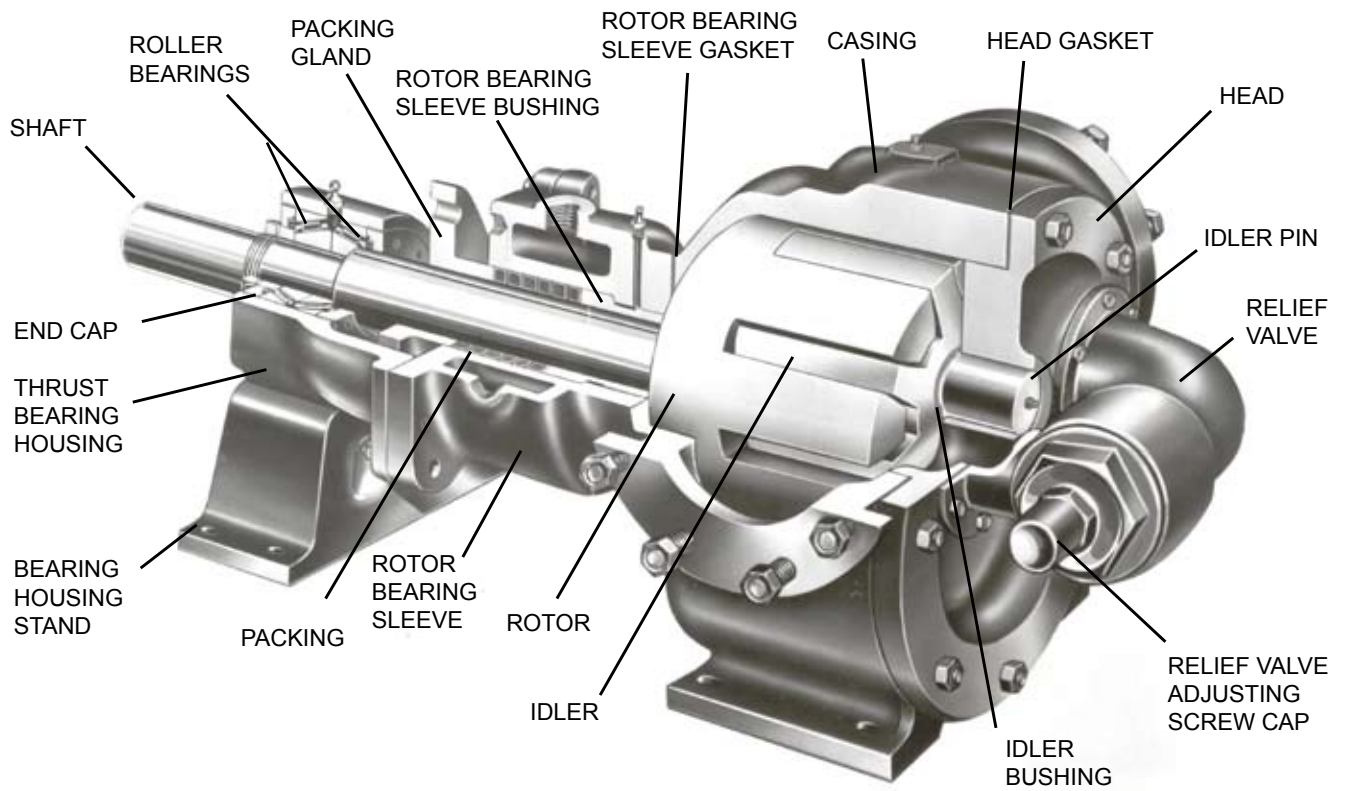
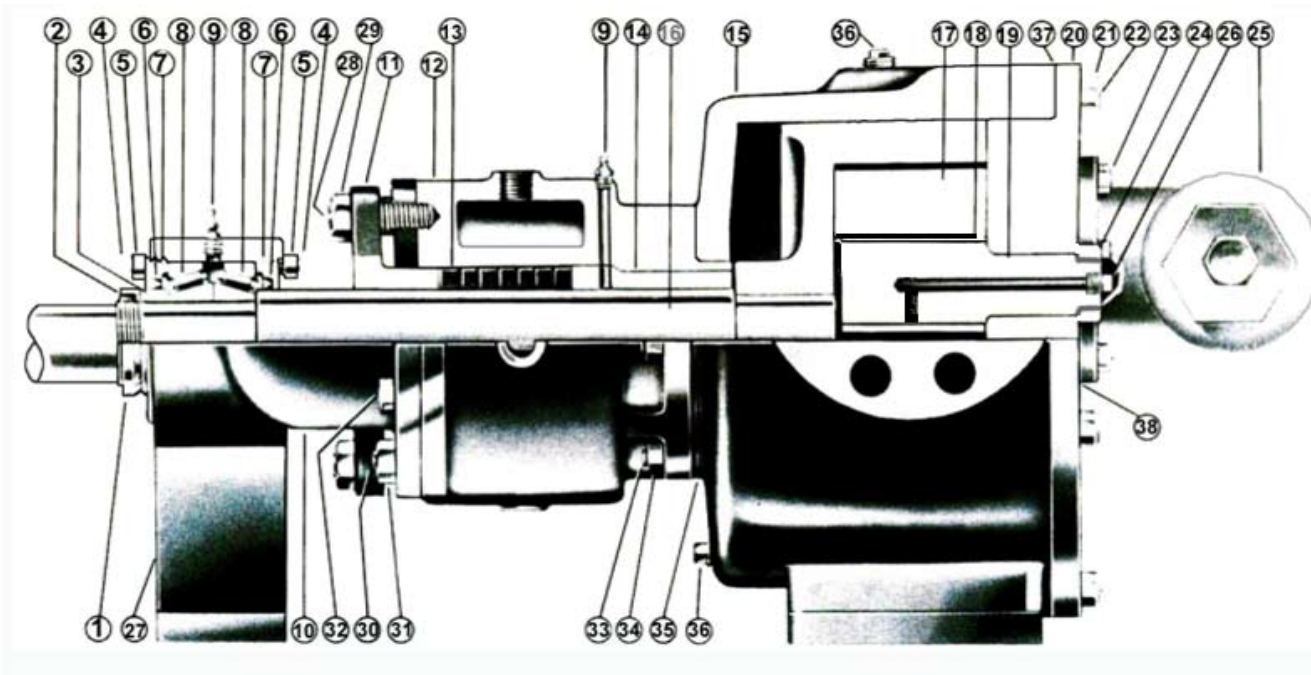

**FIGURE 3**

**CUTAWAY OF PACKED PUMP MODEL N335**

# PACKED PUMPS

## Model N, R, and P335



**FIGURE 4 DETAILS FOR SECTIONAL VIEW - MODELS N, R AND P335**

ITEM	NAME OF PART	ITEM	NAME OF PART	ITEM	NAME OF PART	ITEM	NAME OF PART
1	Locknut	11	Packing Gland	21	Nut For Head	31	Bearing Housing Nut
2	Lockwasher	12	Rotor Bearing Sleeve & Bushing	22	Stud For Head	32	Bearing Housing Capscrew
3	Bearing Spacer Collar	13	Packing	23	Capscrew For Valve	33	Stud For Rotor Bearing Sleeve
4	Capscrew for Adjusting Locknut	14	Bushing, Rotor Bearing Sleeve	24	Idler Pin Nut (Not N)	34	Nut For Rotor Bearing Sleeve
5	End Cap Lock	15	Casing	25	Internal Relief Valve	35	Rotor Bearing Sleeve Gasket
6	Lip Seal	16	Rotor and Shaft	26	Pipe Plug	36	Pipe Plug
7	End Cap	17	Idler and Bushing	27	Bearing Housing Stand	37	Head Gasket
8	Roller Bearing	18	Idler Bushing	28	Packing Gland Stud	38	Relief Valve Gasket
9	Grease Fitting	19	Idler Pin	29	Packing Gland Nut	*	Suck Back line Not Illus.
10	Thrust Bearing Housing	20	Head and Idler Pin	30	Bearing Housing Stud		

## DANGER !

Before opening any Viking pump liquid chamber (pumping chamber, reservoir, relief valve adjusting cap fitting etc.) Be sure:

1. That any pressure in the chamber has been completely vented through the suction or discharge lines or other appropriate openings or connections.
2. That the driving means (motor, turbine, engine, etc.) has been "locked out" or made non-operational so that it cannot be started while work is being done on the pump.
3. That you know what liquid the pump has been handling and the precautions necessary to safely handle the liquid. Obtain a material safety data sheet (MSDS) for the liquid to be sure these precautions are understood.

Failure to follow above listed precautionary measures may result in serious injury or death.

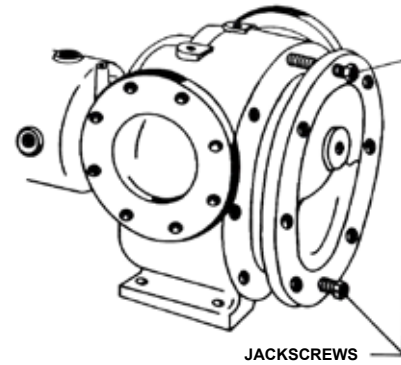
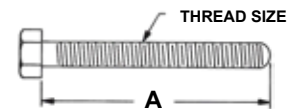

FIGURE 5



PUMP SIZE	NO. SCREWS USED	A	THREAD SIZE (INCH)
N	2	4.00	0.50" - 13 NC
R	2	4.50	0.63" - 11 NC
P	3	5.00	0.50" - 13 NC

FIGURE 6  
MINIMUM JACKSCREW LENGTH

## DISASSEMBLY

1. Mark the head and casing before disassembly to ensure proper reassembly. The idler pin, which is offset in pump head, must be positioned towards and equal distance between the port connections to allow for proper flow of liquid through the pump. (Refer to figure 5)

It is not necessary to remove the relief valve to take the head off the pump; however, removing the relief valve will lessen the total weight of the part. Do not use chain or cable around the relief valve body to support the head during removal. For **PRESSURE RELIEF VALVE INSTRUCTIONS**, refer to page 14.

Remove all nuts from the head. Jackscrews should be used to back the head away from the casing as shown in Figure 5. For proper size and length of jackscrews for pump size refer to the table in Figure 6. The use of a hoist to support head will facilitate its removal.

Back the head away from casing. Do not allow the idler to fall from the idler pin. To prevent this, tilt the top of the head back when removing. Remove the head from pump. If a hoist is not available, cribbing or blocking can be used to support head. This will eliminate having to lift the head into position when reassembling the pump.

2. Remove the head gasket, idler and bushing assembly.
3. Remove the pipe plug from the drain hole in the casing, this breaks the vacuum behind rotor.

4. Remove the packing gland nuts and slide the gland out of the rotor bearing sleeve.
5. Insert a length of hard wood or brass bar through the port opening between the rotor teeth to keep the shaft from turning.
6. Bend the tang on the lock washer up, and with a spanner wrench remove the locknut and lockwasher from the shaft. Refer to Figure 7.
7. Remove the length of hardwood or brass bar from the port opening.
8. Cushion the end of the shaft with a hardwood block or piece of brass and drive the rotor out of casing, being careful to avoid damaging the rotor bearing sleeve bushing. Support the weight of rotor with a hoist. A cable sling can be used around the shaft, or around rotor teeth, to carry the weight of the part.
9. Remove the end cap lockscrews, disengage the end cap locks and with a spanner wrench remove the end caps. Remove the roller bearings.
10. Remove the nuts and capscrews and take off the thrust bearing housing. Remove the packing from the rotor bearing sleeve. **NOTE:** Model P335 has a lantern ring.
11. Check the rotor bearing sleeve bushing while the rotor bearing sleeve is mounted on the casing. If worn, the bushing must be replaced. Disconnect the circulation line and remove the rotor bearing sleeve from casing. A press must be used to remove the old bushing. If the bushing has a shoulder on the stuffing box end, it must be pressed out through

the packing end of the rotor bearing sleeve. If the bushing is carbon graphite, refer to **INSTALLATION OF CARBON GRAPHITE BUSHINGS**, page 13.

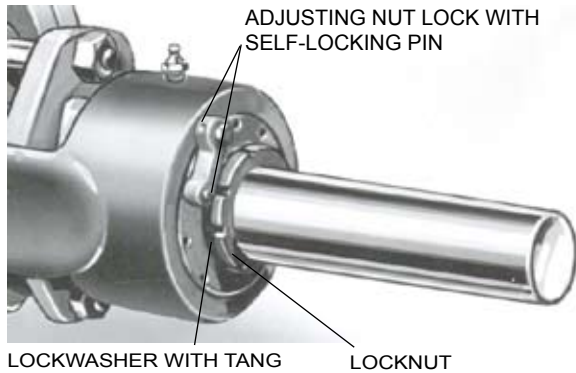

**FIGURE 7**

12. Clean all parts thoroughly and examine for wear and damage. Check the idler bushing and idler pin; replace if necessary.

If the idler pin is to be replaced, the oil groove must be installed facing the center of the crescent on the head.

If lipseals need replacement, press into the end cap, with the lip facing the bearings.

If the idler bushing is to be replaced, a press must be used to remove the old bushing and install the new one. The bushing position after being pressed in should be flush with the face of the idler. For a carbon graphite idler bushing, refer to **INSTALLATION OF CARBON GRAPHITE BUSHINGS**, page 13.

Wash the anti-friction bearings (roller bearings) in clean solvent. Blow out the bearings with compressed air. Do not allow the bearings to spin; turn the bearing slowly by hand. Spinning the bearings will damage the race and rollers. Make sure the bearings are clean, then lubricate with non-detergent SAE 30 weight oil and check for roughness. Roughness can be determined by turning the outer race by hand. **CAUTION:** do not intermix the inner and outer races for the roller bearings. Replace the bearings if they have roughness.

Examine the casing for wear. Check the condition of the casing at the sealing area (surface between suction and discharge port). If the surface is in good condition, the casing need not be replaced.

When making major repairs, such as replacement of a rotor, it is usually considered advisable to install a new head and idler. When making minor repairs, where only an idler bushing and idler pin are required, other new parts are usually not necessary.

## ASSEMBLY

1. Install the rotor bearing sleeve and gasket on the casing. Coat both sides of the gasket with thread sealant (pipe dope) and quickly install the gasket and rotor bearing sleeve on the casing. Place a support under the rotor bearing sleeve to prevent the casing and rotor bearing sleeve from tilting down while the rotor is being installed.
2. Check the casing to be sure the drain plug has been removed.
3. Carefully check the shaft, remove any burrs or rough surfaces to avoid damaging the rotor bearing sleeve bushing while installing the rotor and shaft into the casing. Coat the inner diameter of the rotor bearing sleeve bushing and shaft with a thin coat of non-detergent SAE 30 weight oil.

Support the weight of the rotor with a hoist. A cable sling can be used around the shaft, or rotor teeth to carry the weight of the part while being assembled into the casing.

Place the end of the rotor shaft through the casing, into the bushing slowly turn rotor from right to left while pushing into the casing. When the shaft first protrudes from stuffing box, stop pushing. Check to see if the large diameter of the shaft has protruded far enough into rotor bearing sleeve to permit installing packing rings.

Use packing suitable for the liquid being pumped. Lubricate packing rings with oil, grease or graphite to aid assembly. Packing ring joints should be staggered from one side of shaft to the other. A length of pipe will help set each packing ring.

4. Place the packing gland and inner end cap (position spanner wrench holes on side next to packing gland) with lip seal (lip facing away from packing gland) over the end of the shaft.
5. Push the rotor as far into the casing as it will go.
6. Prior to installing the head, coat the casing face with thread sealant (pipe dope) and place a new .015" head gasket on the mounting studs. Coat the dry side of gasket with thread sealant (pipe dope) Place the idler assembly on the idler pin and prepare to mount the head and idler assembly. (**CAUTION!** do not drop the idler on the foot)

The pump head and casing were marked before disassembly to ensure proper reassembly. If not, be sure the idler pin, which is offset in the pump head, is positioned toward, and equal distance between, the port connections to allow for proper flow of liquid through the pump. Place the head on the pump, slightly tilting the top of the head back away from casing until the crescent enters the inside diameter of rotor. Rotate the idler on idler pin until the idler teeth mesh with the rotor teeth. Raise the head until the face of the head is parallel with face of the casing and work into position. Care must be taken to avoid damaging the head gasket. Fasten to the head to casing with nuts and tighten evenly.

If the relief valve was not removed from head, install on head with adjusting screw cap pointed toward the suction port. Refer to Figure 2, page 2. For **PRESSURE RELIEF INSTRUCTIONS**, refer to page 14.

7. Push the rotor back against the head.
8. Install the drain plug in the casing.
9. Pack the pump with new packing. Refer to Figure 8. Models N and R335 have 6 rings of packing. Model P335 has 8 rings of packing and a lantern ring. The lantern ring should be installed after the fourth ring of packing has been assembled into the packing box.
10. Install the thrust bearing housing on the end of rotor bearing sleeve and tighten the nuts and capscrews securely. It is not necessary to use a gasket between these parts.

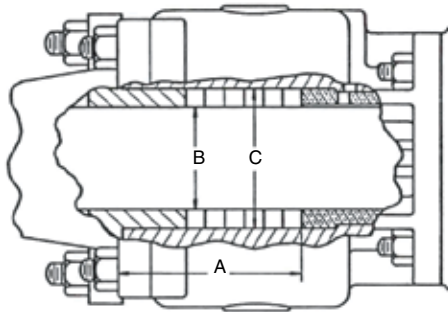

PUMP MODEL	A (INCH)	B (INCH)	C (INCH)
N335	4.63	4.69	3.44
R335	5.63	4.69	3.44
P335	6.38	5.75	4.50

**FIGURE 8  
STUFFING BOX DIMENSIONS**

11. Insert both tapered roller bearings in the thrust bearing housing, large end of inner races together. It is possible to install bearings incorrectly, for proper assembly refer to Figure 9.

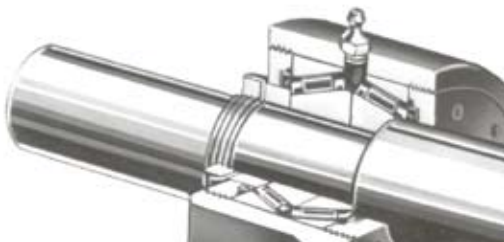

**FIGURE 9**

12. Install the bearing spacer collar on the shaft next to the inner race of the roller bearing.
13. Turn the inner end cap into the thrust bearing housing just far enough to hold in place.

Install the outer end cap and turn in approximately half way.

14. Insert a length of hardwood or brass bar through the port opening between the rotor teeth to keep the rotor from turning.
15. Install the lockwasher, placing the tang in the keyway on the shaft. Tighten the locknut to 170-190 ft – lbs. torque. Bend one tang of the lockwasher into a slot of locknut. If tang does not line up with a slot tighten locknut until it does. Failure to tighten the locknut or engage the lockwasher tang could result in early bearing failure and cause damage to rest of the pump.
16. Remove the length of hardwood or brass bar from the port opening.
17. Install the nuts on the packing gland studs and tighten. Do not over tighten, as it may cause binding on rotor shaft.
18. Reinstall the circulation tubing to the casing and rotor bearing sleeve.
19. Lubricate all grease fittings with multi-purpose grease, NLGI #2.
20. Adjust the pump end clearance. Refer to **THRUST BEARING ADJUSTMENT**, page 13.

**DANGER !**

**Before starting the pump, be sure all drive equipment guards are in place.**

**Failure to properly mount the guards may result in serious injury or death.**

# MECHANICAL SEAL PUMPS

## Model N, R AND P4335

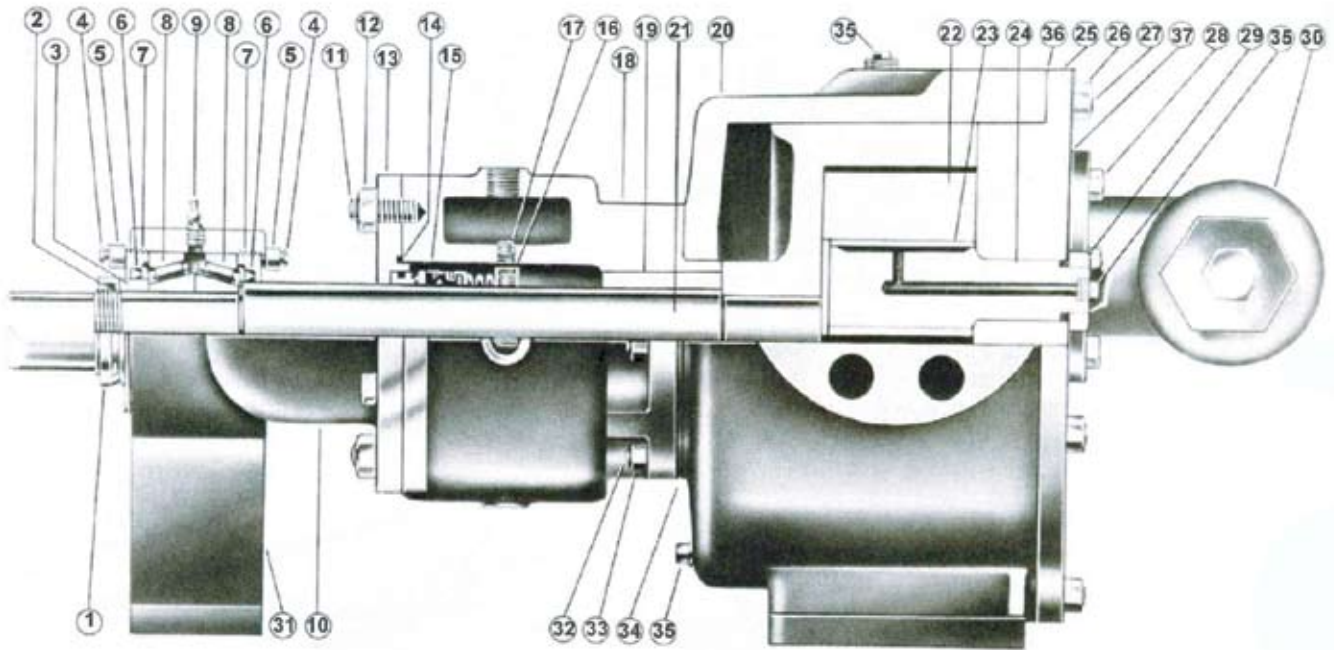

**FIGURE 10 DETAILS FOR SECTIONAL VIEW - MODELS N, R AND P4335**

ITEM	NAME OF PART	ITEM	NAME OF PART	ITEM	NAME OF PART	ITEM	NAME OF PART
1	Locknut	11	Stud For Seal Plate	21	Rotor and Shaft	31	Bearing Housing Stand
2	Lockwasher	12	Nut For Seal Plate	22	Idler & Bushing	32	Stud For Rotor Bearing Sleeve
3	Bearing Spacer Collar	13	Seal Plate	23	Idler Bushing	33	Nut For Rotor Bearing Sleeve
4	Lockscrew for Adjusting Locknut	14	O-Ring Gasket	24	Idler Pin	34	Rotor Bearing Sleeve Gasket
5	End Cap Lock	15	Mechanical Seal (Complete)	25	Head and Idler Pin	35	Pipe Plug
6	Lip Seal	16	Set Collar with Set Screws	26	Nut For Head	36	Head Gasket
7	End Cap	17	Pipe Plug ¼ Socket Head	27	Stud For Head	37	Relief Valve Gasket
8	Roller Bearing	18	Rotor Bearing Sleeve & Bushing	28	Capscrew For Valve	*	Flush line Not Illus.
9	Grease Fitting	19	Bushing, Rotor Bearing Sleeve	29	Idler Pin Nut (Not N)		
10	Thrust Bearing Housing	20	Casing	30	Internal Relief Valve		

# DISASSEMBLY

## DANGER!

Before opening any Viking pump liquid chamber (pumping chamber, reservoir, relief valve adjusting cap fitting etc.) Be sure:

1. That any pressure in the chamber has been completely vented through the suction or discharge lines or other appropriate openings or connections.
2. That the driving means (motor, turbine, engine, etc.) has been "locked out" or made non-operational so that it cannot be started while work is being done on the pump.
3. That you know what liquid the pump has been handling and the precautions necessary to safely handle the liquid. Obtain a material safety data sheet (MSDS) for the liquid to be sure these precautions are understood.

**Failure to follow the above listed precautionary measures may result in serious injury or death.**

1. Mark the head and casing before disassembly to ensure proper reassembly. The idler pin, which is offset in the pump head, must be positioned towards and equal distance between the port connections to allow for proper flow of liquid through the pump. (Refer to figure 5)

It is not necessary to remove the relief valve to take the head off the pump; however, removing the relief valve will lessen total weight of the part. Do not use a chain or cable around the relief valve body to support head during removal. For **PRESSURE RELIEF INSTRUCTIONS**, refer to page 13.

Remove the nuts from the head. Jackscrews should be used to back the head away from the casing. Refer to Figure 11. The proper size and length of jackscrews for the pump size are shown in Figure 12. The use of a hoist to support the head will facilitate its removal.

Back the head away from casing. Do not allow the idler to fall from the idler pin. To prevent this, tilt the top of head back when removing. Remove head from the pump. If a hoist is not available, cribbing or blocking can be used to support the head. This will eliminate having to lift the head into position when reassembling the pump.

2. Remove the head gasket, idler and bushing assembly.
3. To remove the rotor, loosen the set collar behind the mechanical seal. Through the one inch jacket connection

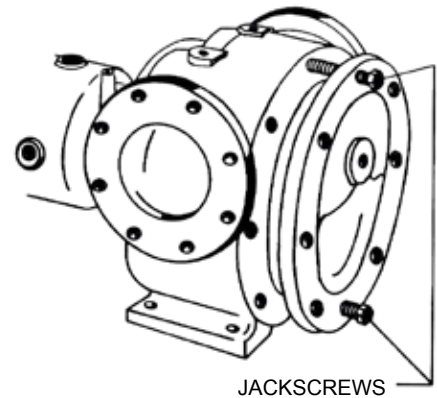
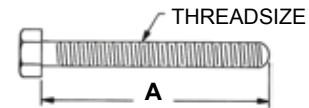

FIGURE 11



PUMP SIZE	NO. SCREWS USED	A	THREAD SIZE (INCH)
N	2	4.00	0.50" - 13 NC
R	2	4.50	0.63" - 11 NC
P	3	5.00	0.50" - 13 NC

FIGURE 12  
MINIMUM JACKSCREW LENGTH

on top of the rotor bearing sleeve, remove the 0.25" socket head pipe plug. Through the same hole loosen the 0.313" socket head setscrews which locks the collar to the shaft. Rotate shaft to be sure all setscrews have been loosened. Refer to figure 10, page 8, items 16 and 17, for the pipe plug to remove and the setscrews to be loosened.

4. Remove the casing drain plug to break the vacuum between back of the rotor and the casing. Remove any deposits of material from the exposed portion of the shaft between the seal plate and the thrust bearing assembly.
5. Insert a length of hardwood or brass through the port opening between the rotor teeth to keep the shaft from turning.
6. Bend the tang on the lockwasher up and with a spanner wrench, remove the locknut and lockwasher from the shaft. Refer to Figure 13.

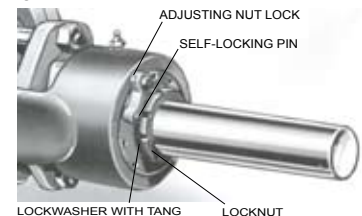

FIGURE 13

7. Remove the length of hardwood or brass bar from the port opening.
8. Cushion the end of the shaft with a hardwood block or piece of brass and drive the rotor out of the casing being careful to avoid damaging rotor bearing sleeve bushing. Support the weight of rotor with a hoist. A cable sling can be used around the shaft, or around the rotor teeth to carry the weight of the part.
9. Loosen the end cap lockscrews, disengage the end cap

locks and with a spanner wrench, remove the end caps. Examine the lipseal and replace if worn.

Remove the roller bearings.

10. Remove the nuts and capscrews and take off the thrust bearing housing.
11. Remove the nuts holding the seal plate and remove seal plate. The stationary seal seat can be removed from the seal plate and the rotating portion of the seal from the rotor bearing sleeve, remove the spring and set collar from the bottom of the seal chamber.
12. Check rotor the bearing sleeve bushing while the rotor bearing sleeve is mounted on the casing. If worn, the bushing must be replaced.

Disconnect the flush line and remove the rotor bearing sleeve from the casing.

A press must be used to remove the old bushing. If the bushing has a shoulder on the stuffing box end, it must be pressed out from the mechanical seal end of the rotor bearing sleeve. Carbon graphite bushings are standard for Model 4335 pumps. To replace carbon graphite bushings, refer to **INSTALLATION CARBON GRAPHITE BUSHINGS**, page 12.

13. Clean all parts thoroughly and examine for wear and damage. If lipseal replacement is needed, press in the end cap with the lip facing the end of the shaft. Check the idler bushing and idler pin, replace if necessary.

If the idler pin is to be replaced, the oil groove on the pin must be installed facing the center of the crescent on the head.

If the idler bushing is to be replaced, a press must be used to remove the old bushing and install new. The bushing position after being pressed in should be flush with the face of the idler. For carbon graphite idler bushing, refer to **INSTALLATION OF CARBON GRAPHITE BUSHINGS**, page 12.

14. Wash the bearing in clean solvent. Blow out bearings with compressed air. Do not allow the bearings to spin; turn the bearing slowly by hand. Spinning the bearings will damage the race and rollers. Make sure the bearings are clean, then lubricate with non-detergent SAE 30 weight oil and check for roughness. Roughness can be determined by turning the outer race by hand. **CAUTION:** do not intermix the inner and outer races for the roller bearings.
15. Examine the casing for wear. Check the condition of the casing at the seal area (surface between suction and discharge ports). If the surface is in good condition, the casing need not be replaced. When making major repairs, such as replacement of a rotor, it is usually considered advisable to install a new head and idler. When making minor repairs, when only an idler bushing and idler pin are required, other new parts are usually not necessary.
16. Inspect the mechanical seal for wear or damage. Refer to Figure 14 for mechanical seal list of parts. In general, if the pump has been operated long enough to exhibit other worn parts, it is likely the seal will have

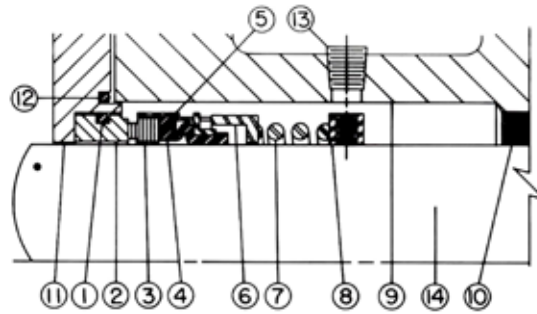

LIST OF PARTS	
1. O-Ring Seat Gasket	8. Set Collar with set screws
2. Stationary Seat	9. Rotor Bearing Sleeve
3. Rotating Face (Washer)	10. Rotor Bearing Sleeve Bushing
4. Bellows	11. Seal Holder Plate
5. Metal Parts (retainer, drive band)	12. O-Ring Gasket for seal holder plate
6. Spring Adapter	13. Pipe Plug
7. Spring	14. Shaft

NOTE: Items one through seven comprise the complete mechanical seal

**FIGURE 14 MECHANICAL SEAL**

to be replaced. Replacing individual seal parts is not recommended, i.e., a used seal washer will not perform satisfactorily when run against a new stationary seat.

## ASSEMBLY

Standard Mechanical Seal (Synthetic Rubber Bellows Type)

Prepare all parts for reassembly ahead of time. Pack roller bearings with multi-purpose grease, NLGI # 2 and have all new gaskets on hand.

Be especially careful to keep mechanical seal parts clean. Minute dirt particles especially on the seal faces, will cause leakage. Never touch the seal faces with anything except clean hands or a clean cloth.

Once the rotating portion of mechanical seal is installed on rotor shaft, it is necessary to assemble parts as quickly as possible to ensure the seal does not stick to the shaft in the wrong axial position. The seal should be expected to stick to the shaft after several minutes setting time.

1. Deburr the threads on the rotor shaft with a fine file and place a layer of tape over the threads to protect the rotor bearing sleeve bushing during assembly. Gently radius leading edge of the largest diameter on the shaft (.03 inch is sufficient to aid in seal installation). Smooth the radius with a very fine grit emery cloth. Polish the rotor shaft from leading edge through mechanical seal area with the emery cloth. Any scratches left on shaft in seal area will provide leakage paths under mechanical seal.
2. Install the rotor bearing sleeve and gasket on the casing. Coat both sides of the gasket with thread sealant (pipe

dope) and quickly install the gasket and rotor bearing on the casing. Place a support under the rotor bearing sleeve to prevent the casing and rotor bearing sleeve from tilting down while the rotor is being installed.

3. Check the casing to be sure the drain plug has been removed.
4. Coat the inner diameter of the rotor bearing sleeve bushing with a thin coat of non-detergent SAE 30 weight oil.

Support the weight of the rotor with a hoist. A cable sling can be used around the shaft, or around the rotor teeth, to carry the weight of part while being assembled into the casing.

Place the end of rotor shaft through casing into bushing. Do not allow any portion of the shaft to strike the bushing. A carbon graphite bushing can be severely damaged if struck. Slowly turn the rotor from right to left while pushing into the casing. Push the rotor as far into casing as it will go.

5. Prior to installing the head, coat the casing face with thread sealant (pipe dope) and place a new .015 inch head gasket on the mounting studs. Coat the dry side of the gasket with thread sealant (pipe dope) and prepare to mount the head and idler assembly.
6. The pump head and casing were marked before disassembly to ensure proper reassembly. If not, be sure the idler pin, which is off set in the pump head, is positioned toward and equal distance between the port connections to allow for an even flow of liquid through the pump.

Place the head on pump, slightly tilting top of the head back away from casing until the crescent enters inside diameter of the rotor. Rotate the idler on idler pin until the idler teeth mesh with the rotor teeth. Raise the head until the face of head is parallel with the face of casing and then work into position. Care must be taken to avoid damaging the head gasket. Fasten the head to casing with head nuts and tighten evenly.

If the relief valve was removed from the head, install on head with the adjusting screw cap pointed toward suction port. Refer to figure 15. For **PRESSURE RELIEF VALVE INSTRUCTIONS**, refer to page 13.

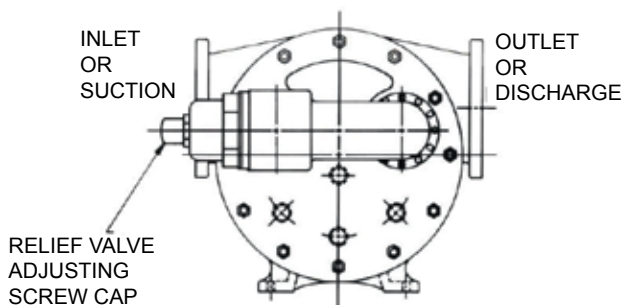

**FIGURE 15**

7. Push the rotor back against the head.  
Install the drain plug in the casing.
9. Wipe the shaft clean in seal area and thoroughly coat with non-detergent SAE 30 weight oil.

Before installing the parts contained in the mechanical seal, refer to Figure 14 to become familiar with part name and location in rotor bearing sleeve.

10. Install the set collar on the shaft in the rotor bearing sleeve directly under the tapped access hole. The center line of the collar set screws (5/16" socket head) must line up with the center line of the access hole. Rotate the shaft and tighten all setscrews.

Replace the pipe plug in seal access hole.

11. Slide the seal spring on the shaft and into the seal chamber against the set collar. Place the spring adapter, with the open side facing the end of shaft against the spring. Place the tapered installation sleeve on shaft.

**NOTE:** The tapered installation sleeve is available from factory, at additional cost, for the N & R size pumps.

12. Apply a generous amount of non-detergent SAE 30 weight oil to the large diameter of the shaft, tapered installation sleeve and the inner diameter of the mechanical seal rubber parts.
13. Coat the seal holder chamber and the o-ring seat gasket with non-detergent SAE 30 weight oil and press in the seal seat with lapped faced out. Protect the face of the seal seat with a clean piece of cardboard while pressing into place.

14. Coat the seal holder plate o-ring gasket with non-detergent SAE 30 weight oil and install over the pilot of plate.

15. Coat the inside diameter of the rotating face of seal with non-detergent SAE 30 weight oil and start the tail of bellows over installation sleeve on shaft. A twisting motion while pushing will aid in sliding the seal on the sleeve. Push the seal against seal adapter. Do not touch the carbon rotating face with anything except clean hands or a clean cloth.

Check to make sure the adapter is not cocked.

16. Install the seal holder plate over the shaft on mounting studs until the seal faces touch.

Start the nuts on the mounting studs. Pull the seal holder plate evenly against the face of the seal chamber with the nuts, alternately tightening one and then the other. This will compress the mechanical seal to correct operating length and compress the plate gasket to seal off the seal chamber.

17. Remove the tapered installation sleeve.
18. Place the inner end cap with lipseal (lip facing end of shaft) on shaft.
19. Install the thrust bearing housing on end of the rotor bearing sleeve and tighten the nuts and capscrews securely.

It is not necessary to use a gasket between these parts.

20. Insert both tapered roller bearings in the thrust bearing housing, large end of the inner races together.

**CAUTION:** It is possible to install bearings incorrectly. For proper assembly, refer to Figure 17.

21. Install the bearing spacer collar on the shaft next to the inner race of the roller bearing.



FIGURE 17

### DANGER !

Before starting the pump, be sure all drive equipment guards are in place.

Failure to properly mount guards may result in serious injury or death

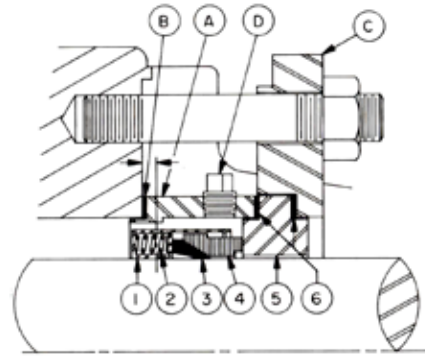

FIGURE 18

PTFE Fitted Mechanical Seal Assembly  
For Models N-R4333, 4335 & 4337

1. Retainer Cartridge
2. Springs
3. PTFE Shaft Ring (wedge)
4. Rotating Face (washer)
5. Stationary Seal Seat
6. Seat Gaskets

Seal Mounting Parts

- A. Packing box extension
- B. Packing box extension gasket
- C. Seal plate
- D. Flush openings

## OPTIONAL MECHANICAL SEAL (PTFE Fitted Type)

Three components are furnished in the mechanical seal assembly: Refer to Figure 18, item numbers 1 thru 6.

1. The rotating assembly in which a retainer cartridge encloses a spring loaded PTFE shaft ring and polished rotating face. Set screws located around the outside of the retainer cartridge are provided for securing rotating assembly to pump shaft.
2. The stationary seal seat.
3. Two seal seat gaskets.

Three pump parts necessary for mounting PTFE mechanical seal are illustrated in Figure 18, item letters A, B, C and D.

1. The packing box extension, has a machine pilot on the end for installation in the rotor bearing sleeve and two tapped holes for the seal flush.
2. The packing box extension gasket.
3. The seal plate is machined to accept seal seat and gasket.

## DISASSEMBLY

1. Disassemble the pump per steps 1 thru 10 on page 8 under **MECHANICAL SEAL DISASSEMBLY**.
2. Remove the seal plate nuts from the studs and remove the seal plate, gaskets and stationary seat.
3. If the pump is equipped with a flush line, disconnect from the packing box extension.
4. Remove the packing box extension and gasket.
5. Loosen the set screws in the mechanical seal retainer cartridge and remove from the rotor shaft. Refer to Figure 18.

## ASSEMBLY

1. Reassemble the pump per steps 1 thru 9 on pages 10 & 11, under **ASSEMBLY, STANDARD MECHANICAL SEAL**. Step 1 (deburring shaft) is very critical prior to the seal assembly.

**NOTE:** The tapered installation sleeve is available from factory, at additional cost, for the N & R size pumps from Viking Pump Division.

2. Coat the large diameter of shaft, tapered sleeve, and inside diameter of seal with non-detergent SAE 30 weight oil.

3. Place the tapered installation sleeve (if on hand) and install the seal on the shaft over the tapered sleeve. Position the seal on the shaft inside the rotor bearing sleeve bore with end of seal located .19 inch inside the machined face of the rotor bearing sleeve. Refer to Figure 18.
4. Tighten all the seal drive set screws securely to the shaft.
5. Remove the tapered installation sleeve.
6. Place the gasket on the packing box extension and install the extension with the machined pilot inside the rotor bearing sleeve bore.
7. Place the seat gasket over the shoulder of the stationary seal seat and insert seat into the seal plate. Place the remaining seat gasket over shoulder of polished surface of stationary seat. Refer to Figure 18.
8. Place the seal plate with the stationary seat over the mounting the studs and push the shoulder of stationary seat into the packing box extension, the polished face against the carbon rotating face.
9. Install the nuts on mounting studs and against seal holder. Tighten the nuts evenly so the seal plate and stationary seat will not be distorted when seal is compressed.
10. Reassemble flush line to packing box extension.

**AT THIS POINT, FINISH ASSEMBLY PROCEDURES STARTING AT STEP 18, page 10.**

## THRUST BEARING ADJUSTMENT

Loosen the capscrews retaining the end cap locks on both the inner and outer end caps. Slide the end cap locks out far enough so the pins are no longer in the end cap retaining holes. Using the spanner wrench provided with the pump, turn the inner end cap towards the pump. Turn the outer end cap in until the rotor shaft cannot be turned. With grease pencil or chalk, make a reference mark on the bearing housing OD and outer end cap. Back off the outer end cap approximately 4 holes. One hole is equivalent to .005 inch end clearance. Align the nearest end cap hole with the outer end cap lock. Tighten the setscrew holding this lock. Tighten the inner end cap until it is snug. Do not over tighten. Back off slightly to align the nearest end cap hole with the end cap lock. Tighten this setscrew. It is important not to tighten the inner end cap to make the end cap lock align. This will cause the tapered roller bearings to run too tightly and heat up. Turn the rotor shaft to make sure it turns freely. If not, repeat the above procedure.

Standard catalog pumps require the following end clearance settings.

Pump Size	Standard End Clearance (Inch)
N	.015
R	.020
P	.025

Pumps built for viscous liquid or high temperature service may require extra end clearance. Each hole on the end cap is about .004 inch additional end clearance. Consult an authorized Viking distributor or the factory for further information.

## INSTALLATION OF CARBON GRAPHITE BUSHINGS

When installing carbon graphite bushings, extreme care must be taken to prevent breaking. Carbon graphite is a brittle material and easily cracked. If cracked, the bushing will quickly disintegrate. Using a lubricant and adding a chamfer on the bushing and the mating part will help with installation. The additional precautions listed below must be followed for proper installation.

1. A press must be used for installation.
2. Be certain the bushing is started straight.
3. Do not stop the pressing operation until the bushing is in the proper position; starting and stopping will result in a cracked bushing.
4. Check the bushing for cracks after installation.

Carbon graphite bushings with extra interference fits are frequently furnished for high temperature operation. These bushings must be installed by a shrink fit.

1. Heat the rotor bearing sleeve or idler to 750° F.
2. Install cool bushings with a press.
3. If facilities are not available to reach 750° F. temperature, it is possible to install with 450° F. temperature; however, the lower the temperature, the greater the possibility of cracking the bushing.

Consult factory with specific questions on high temperature applications. Refer to Engineering Service Bulletin ESB-3.

# PRESSURE RELIEF VALVE INSTRUCTIONS

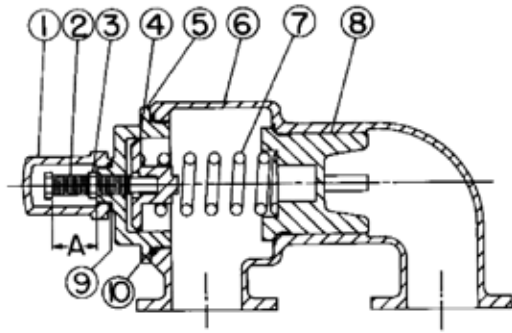

LIST OF PARTS	
1. Valve Cap	6. Valve Body
2. Adjusting Screw	7. Valve Spring
3. Lock Nut	8. Poppet
4. Spring Guide	9. Cap Gasket
5. Bonnet	10. Bonnet Gasket

FIGURE 19

Mark valve and head before disassembly to ensure proper reassembly.

1. Remove the valve cap.
2. Measure and record the length of extension of adjusting screw. Refer to "A" on Figure 19.
3. Loosen the locknut and back out the adjusting screw until the spring pressure is being released.
4. Remove the bonnet, spring guide, spring and poppet from the valve body. Clean and inspect all parts for wear and damage and replace as necessary.

## ASSEMBLY

Reverse the procedures outlined under **DISASSEMBLY**. If the valve is removed for repairs, be sure to replace in the same position. The relief valve adjusting screw cap must **always** point towards suction side of the pump. If the pump rotation is reversed, remove the relief valve and turn end for end. Refer to Figure 20.

## DISASSEMBLY

### DANGER !

Before opening any Viking pump liquid chamber (pumping chamber, reservoir, relief valve adjusting cap fitting etc.) Be sure:

1. That any pressure in the chamber has been completely vented through the suction or discharge lines or other appropriate openings or connections.
2. That the driving means (motor, turbine, engine, etc.) Has been "locked out" or made non- operational so that it cannot be started while work is being done on pump.
3. That you know what liquid the pump has been handling and the precautions necessary to safely handle the liquid. Obtain a material safety data sheet (MSDS) for the liquid to be sure these precautions are understood.

Failure to follow the above listed precautionary measures may result in serious injury or death.

### DANGER !

Before starting the pump, be sure all drive equipment guards are in place.

Failure to properly mount guards may result in serious injury or death.

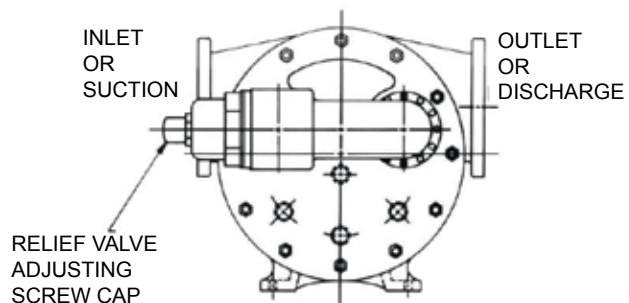

FIGURE 20

## PRESSURE ADJUSTMENT

If a new spring is installed or if the pressure setting of the pressure relief valve is to be changed from that which the factory has set, the following instructions must be carefully followed.

1. Carefully remove the valve cap, which covers the adjusting screw.

Loosen the locknut, which locks the adjusting screw so the pressure setting will not change during operation of pump.



# TECHNICAL SERVICE MANUAL

**HEAVY DUTY PUMPS  
SERIES 335 AND 4335  
SIZES N, R, AND P**

SECTION	TSM 143
PAGE	15 OF 15
ISSUE	D

2. Install a pressure gauge in the discharge line for the actual adjustment operation.
3. Turn the adjusting screw in to increase pressure and out to decrease pressure.
4. With the discharge line closed at a point beyond pressure gauge, the gauge will show maximum pressure valve will allow while pump is in operation.

## IMPORTANT

When ordering parts for the pressure relief valve, always give the model number and serial number of pump as it appears on the nameplate and name of part wanted. When ordering springs, be sure to give the pressure settings desired.



## WARRANTY

Viking warrants all products manufactured by it to be free from defects in workmanship or material for a period of one (1) year from date of startup, provided that in no event shall this warranty extend more than eighteen (18) months from the date of shipment from Viking. If, during said warranty period, any products sold by Viking prove to be defective in workmanship or material under normal use and service, and if such products are returned to Viking's factory at Cedar Falls, Iowa, transportation charges prepaid, and if the products are found by Viking to be defective in workmanship or material, they will be replaced or repaired free of charge, FOB. Cedar Falls, Iowa.

Viking assumes no liability for consequential damages of any kind and the purchaser by acceptance of delivery assumes all liability for the consequences of the use or misuse of Viking products by the purchaser, his employees or others. Viking will assume no field expense for service or parts unless authorized by it in advance.

Equipment and accessories purchased by Viking from outside sources which are incorporated into any Viking product are warranted only to the extent of and by the original manufacturer's warranty or guarantee, if any.

**THIS IS VIKING'S SOLE WARRANTY AND IS IN LIEU OF ALL OTHER WARRANTIES, EXPRESSED OR IMPLIED, WHICH ARE HEREBY EXCLUDED, INCLUDING IN PARTICULAR ALL WARRANTIES OF MERCHANTABILITY OR FITNESS FOR A PARTICULAR PURPOSE. No officer or employee of IDEX Corporation or Viking Pump, Inc. is authorized to alter this warranty.**