



TECHNICAL SERVICE MANUAL

HEAVY-DUTY BRACKET MOUNTED PUMPS
 SERIES 225 AND 4225
 SIZES LS, Q, QS, M

SECTION	TSM 142.2
PAGE	1 OF 13
ISSUE	D

CONTENTS

Introduction	1
Special Information	2
Maintenance	2
Packed Pumps	4
Mechanical Seal Pumps	7
Thrust Bearing Adjustment	11
Installation of Carbon Graphite Bushings	11
Safety Relief Valve Instructions	12

INTRODUCTION

The illustrations used in this manual are for identification purposes only and cannot be used for ordering parts. Obtain a parts list from the factory or a Viking® representative. Always give complete name of part, part number and material with model number and serial number of pump when ordering repair parts. The unmounted pump or pump unit model number and serial number are on the nameplate.

In the Viking model number system, basic size letters are combined with the series number (225 and 4225) and used to indicate either an unmounted pump or mounted pump unit.



SIZE LS - FIGURE 1
 (Shown with Jacketed Head Plate)

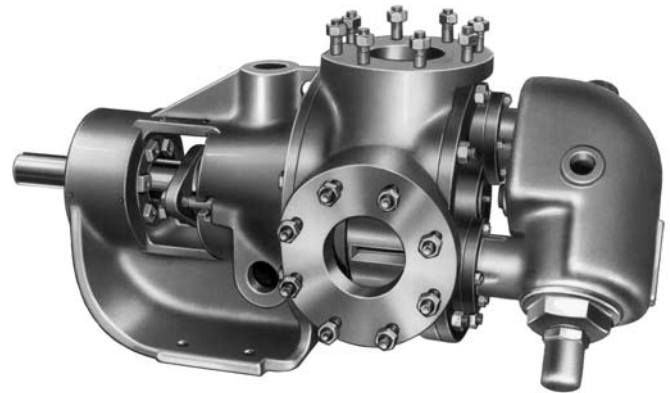

SIZES Q, QS AND M - FIGURE 2
 (Shown with Jacketed Relief Valve Type Head)

UNMOUNTED PUMP		UNITS
PACKED	MECH. SEAL	
LS225	LS4225	Units are designated by the unmounted pump model numbers followed by a letter indicating drive style. V = V-belt D = Direct Connected R = Viking Speed Reducer P = Commercial Speed Reducer
Q225	Q4225	
QS225	QS4225	
M225	M4225	

This manual deals only with Series 225 and 4225 Heavy Duty Bracket Mounted Pumps. **Refer to Figures 1 through 13** for general configuration and nomenclature used in this manual. Pump specifications and recommendations are listed in Catalog Section 142, Series 225 and 4225 Heavy Duty Bracket Mounted Pumps.

SPECIAL INFORMATION

DANGER !

Before opening any Viking pump liquid chamber (pumping chamber, reservoir, relief valve adjusting cap fitting, etc.)

Be sure:

1. That any pressure in the chamber has been completely vented through the suction or discharge lines or other appropriate openings or connections.
2. That the driving means (motor, turbine, engine, etc.) has been “locked out” or made non-operational so that it cannot be started while work is being done on pump.
3. That you know what liquid the pump has been handling and the precautions necessary to safely handle the liquid. Obtain a material safety data sheet (MSDS) for the liquid to be sure these precautions are understood.

Failure to follow above listed precautionary measures may result in serious injury or death.

JACKETING of the bracket and head provide large chambers at both ends of the pumping chamber and around the stuffing box for temperature control of the product in the pump.

ROTATION: Viking pumps operate equally well in a clockwise or counterclockwise rotation. When rotation changes, the suction and discharge is reversed.

PRESSURE RELIEF VALVES:

1. Viking pumps are positive displacement pumps and must be provided with some sort of pressure protection. This may be a relief valve mounted directly on the pump, an inline pressure relief valve, a torque limiting device or a rupture disk.
2. There are relief valve options available on those pump models designed to accept a relief valve. Options may include a return to tank relief valve and a jacketed relief valve. Pumps equipped with a jacketed head plate are generally not available with a relief valve.
3. If pump rotation is to be reversed during operation, pressure protection must be provided on *both* sides of pump.
4. Relief valve adjusting screw cap must always point towards suction side of pump. If pump rotation is reversed, remove pressure relief valve and turn end for end. **Refer to Figures 1 and 2.**

5. Pressure relief valves cannot be used to control pump flow or regulate discharge pressure.

For additional information on pressure relief valves, **Refer to Technical Service Manual TSM000 and Engineering Service Bulletin ESB-31.**

SPECIAL MECHANICAL SEALS:

Extra care should be taken in repair of these pumps. Be sure to read and follow all special instructions supplied with your pump.

MAINTENANCE

The series 225 and 4225 pumps are designed for long, trouble-free service life under a wide variety of application conditions with a minimum of maintenance. The points listed below will help you get this long service life from your pump.

LUBRICATION: External lubrication must be applied slowly with a hand gun to all lubrication fittings every 500 hours of operation with multi-purpose grease, NLGI #2. Do not over-grease. Applications involving very high or low temperatures will require other types of lubrication. **Refer to Engineering Service Bulletin ESB-515.** Consult factory with specific lubrication questions.

PACKING ADJUSTMENT: New packed pumps generally require some initial packing adjustment to control leakage as packing “runs in”. Make initial packing adjustments carefully and do not over-tighten the packing gland. After initial adjustment, occasional inspection will reveal the need for packing gland adjustment and/or replacement of the packing. **Refer to instructions under Disassembly, page 5, and Assembly, page 6,** regarding repacking the pump.

END CLEARANCE ADJUSTMENT: After long term operation, it is sometimes possible to improve the performance of the pump, without major repair, through adjustment of end clearance of the pump. **Refer to Instructions under Thrust Bearing Adjustment, page 10,** for information regarding this procedure.

CLEANING THE PUMP: It is good practice to keep the pump as clean as possible. This will facilitate inspection, adjustment and repair work and help prevent omission of lubrication of fittings covered or hidden with dirt.

STORAGE: If the pump is to be stored or not used for any appreciable length of time, it should be drained, and then a light coat of lubricating and preservative oil should be applied to the internal parts. Lubricate all fittings.

MAINTENANCE

SUGGESTED REPAIR TOOLS: The following tools must be available to properly repair Series 225 and 4225 pumps. These tools are in addition to standard mechanics' tools such as open end wrenches, pliers, screwdrivers, etc. Most of the items can be obtained from an industrial supply house.

1. Soft Headed hammer
2. Allen wrenches (some mechanical seals and set collars)
3. Packing hooks, flexible (packed pumps)
Large for 0.375 inch and up cross section packing
4. Mechanical seal installation sleeve
5. Bearing locknut spanner wrench
(Source: #471 J. H. Williams & Co. or equal)
6. Spanner wrench, adjustable pin type for use on double end caps (Source: #482 J. H. Williams & Co. or equal)
7. Brass bar
8. Arbor press

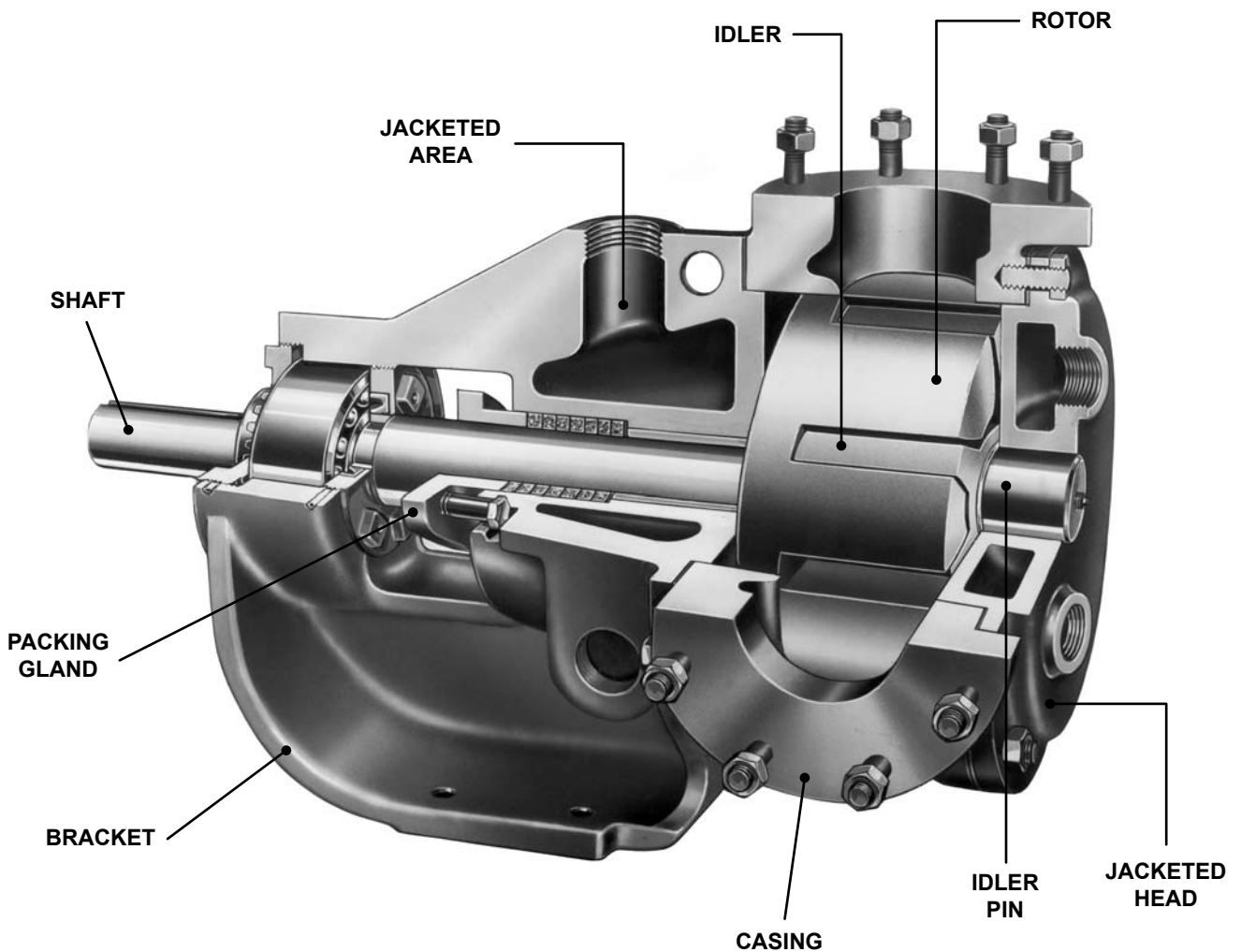
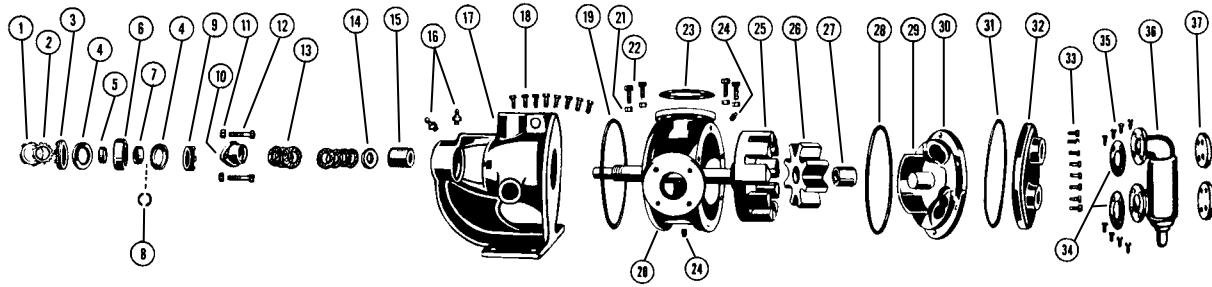

FIGURE 3
Cutaway View Of Packed Pump Model M225 with Callouts (QS size casing has opposite ports)

PART 1 - PACKED PUMPS



EXPLODED VIEW FOR MODEL LS225

ITEM	NAME OF PART	ITEM	NAME OF PART	ITEM	NAME OF PART
1	Locknut	14	Packing Retainer Washer	27	Idler Bushing
2	Lockwasher	15	Bracket Bushing	28	Head Gasket
3	End Cap (Outer)	16	Grease Fitting	29	Idler Pin
4	Lip Seal for End Cap	17	Bracket and Bushing	30	Head and Idler Pin
5	Bearing Spacer Collar (Outer)	18	Capscrew for Bracket	31	Gasket for Jacket Head Plate
6	Ball Bearing	19	Bracket Gasket	32	Jacket Head Plate
7	Bearing Spacer Collar (Inner)	20	Casing	33	Capscrew for Head
8	Ring, Half Round	21	Nut for Flanges	34	Relief Valve Gasket
9	End Cap (Inner)	22	Capscrew for Flanges	35	Capscrew for Relief Valve
10	Packing Gland	23	Pipe Flange Gasket	36	Internal Relief Valve
11	Packing Gland Nut	24	Pipe Plug	37	Cover Plate, Relief Valve
12	Packing Gland Capscrew	25	Rotor and Shaft		
13	Packing	26	Idler and Bushing		

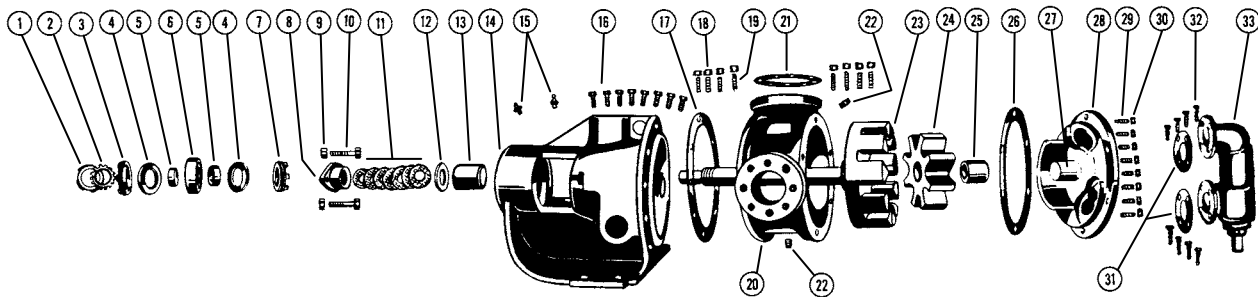

EXPLODED VIEW FOR MODELS Q, QS AND M225

ITEM	NAME OF PART	ITEM	NAME OF PART	ITEM	NAME OF PART
1	Locknut	12	Packing Retainer Washer	23	Rotor and Shaft
2	Lockwasher	13	Bracket Bushing	24	Idler and Bushing
3	End Cap (Outer)	14	Bracket and Bushing	25	Idler Bushing
4	Lip Seal for End Cap	15	Grease Fitting	26	Head Gasket
5	Bearing Spacer Collar (Outer)	16	Capscrew for Bracket	27	Idler Pin
6	Ball Bearing	17	Bracket Gasket	28	Head and Idler Pin
7	End Cap (Inner)	18	Nut for Flanges	29	Stud for Head
8	Packing Gland	19	Stud for Flanges	30	Nut for Head
9	Packing Gland Nut	20	Casing (QS size has opposite ports)	31	Relief Valve Gasket
10	Packing Gland Capscrew	21	Pipe Flange Gasket	32	Capscrew for Relief Valve
11	Packing	22	Pipe Plug	33	Internal Relief Valve

DISASSEMBLY

DANGER !

Before opening any Viking pump liquid chamber (pumping chamber, reservoir, relief valve adjusting cap fitting, etc.) Be sure:

1. That any pressure in the chamber has been completely vented through the suction or discharge lines or other appropriate openings or connections.
2. That the driving means (motor, turbine, engine, etc.) has been "locked out" or made non-operational so that it cannot be started while work is being done on pump.
3. That you know what liquid the pump has been handling and the precautions necessary to safely handle the liquid. Obtain a material safety data sheet (MSDS) for the liquid to be sure these precautions are understood.

Failure to follow above listed precautionary measures may result in serious injury or death.

1. Mark head and casing before disassembly to make sure they are reassembled properly. Remove the head from the pump.

CAUTION: DO NOT ALLOW THE IDLER TO FALL FROM THE IDLER PIN.

Tilting the top of the head back as it is removed will prevent this occurrence. Avoid damaging the head gasket if possible. If pump is furnished with a relief valve, it need not be removed from head or disassembled at this point. Refer to **Pressure Relief Valve Instructions, page 12**. If the pump has a jacket head plate, this plate will separate from the head when the head is removed from the pump. The gasket for jacket head plate between the head and the jacket head plate should be removed and the gasket surfaces on the above parts cleaned. Disassembly will probably require replacement of the gasket for jacket head plate between the pump head and jacket head plate.

These gaskets should be carried as spare parts for pumps thus equipped.

2. Remove the idler and bushing assembly.
3. Bend up tang of lockwasher and with a spanner wrench remove the locknut and lockwasher from the shaft.
NOTE: A piece of hardwood or brass inserted in casing port and between rotor teeth will prevent the shaft from turning.
4. Remove the packing gland nuts.

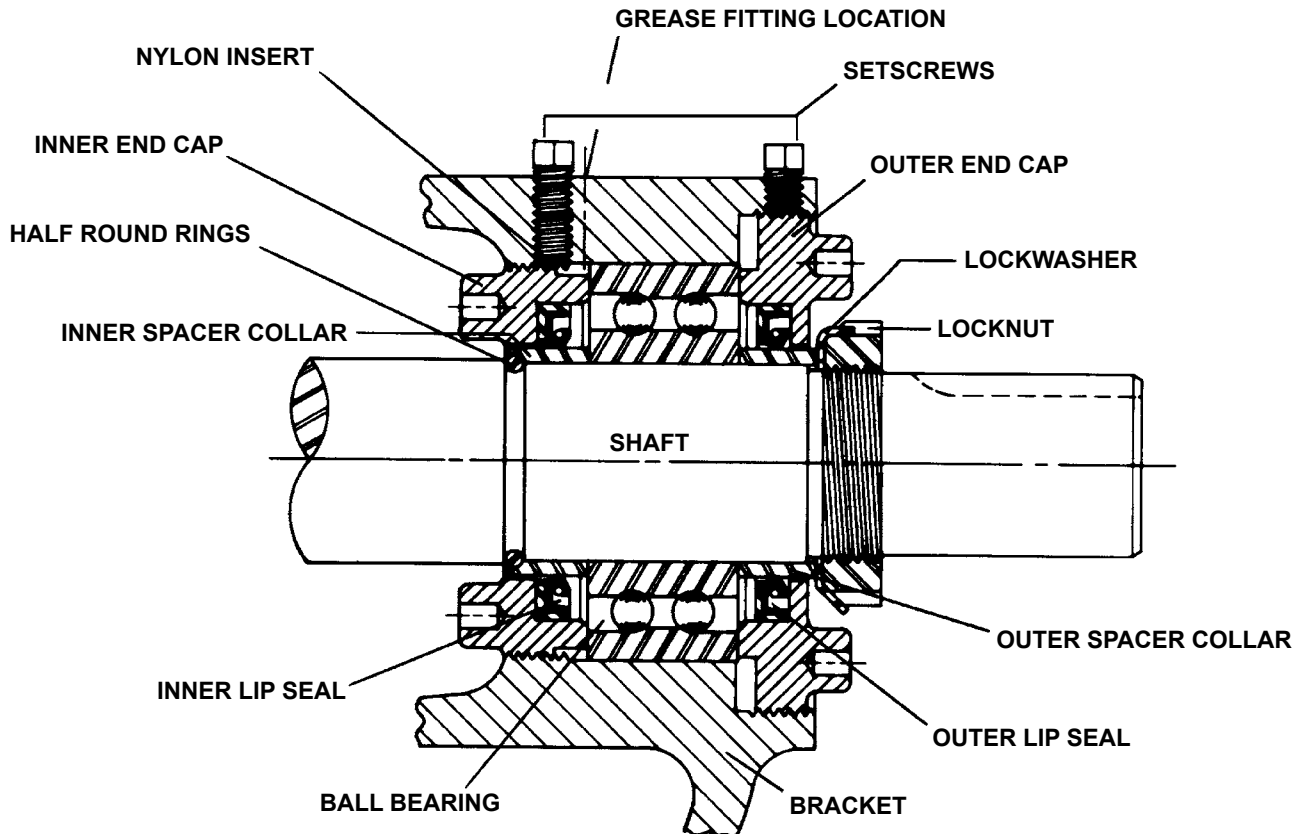

FIGURE 4

5. Tap the shaft forward approximately ½ inch and check for a pair of half circle, round wire rings under the inner bearing spacer collar. **See Figure 4.**

NOTE: These must be removed before rotor and shaft can be removed from the pump. (These rings are not used in Q, QS and M size pumps.)

6. Carefully remove rotor and shaft to avoid damage to the bracket bushing.
7. Remove the packing gland from side of bracket.
8. Loosen the four setscrews over the inner and outer end caps. Remove both end caps, lip seals and bearing spacer collars. **See Figure 4.**

The inner cap can be removed through the side opening of the bracket.

9. Remove the packing and packing retainer washer.
10. Clean all parts thoroughly and examine for wear and damage. Check lip seals, ball bearings, bushings and idler pin and replace if necessary. Check all other parts for nicks, burrs, excessive wear and replace if necessary.

Wash bearings in clean solvent. Blow out bearings with compressed air. Do not allow bearings to spin; turn them slowly by hand. Spinning bearings will damage race and balls. Make sure bearings are clean, then lubricate with non-detergent SAE 30 weight oil and check for roughness. Roughness can be determined by turning outer race by hand.

If bearings have roughness, bearings will need to be replaced.

11. Casing can be checked for wear and/or damage while still mounted on bracket.

ASSEMBLY

1. Install the bracket bushing. (If carbon graphite **see “Installation of Carbon Graphite Bushings” page 11**).
2. Assemble the rotor and shaft in the bracket. Start the end of the shaft in the bracket bushing and turn from right to left, slowly, pushing the rotor into the casing.
3. Place the packing retainer washer in the bottom of the packing chamber and pack the pump. It is good practice to install a set of new packing. The pump should be packed with a packing suitable for the liquid being pumped. Install and seat each ring of packing one at a time, staggering the ring joints from one side of the shaft to the other. Lubricate the packing rings with oil, grease or graphite to aid assembly. A length of pipe or tubing will help to install and seat each packing ring.
4. Install the packing gland, capscrews and nuts. Back the rotor and shaft out of the casing just far enough to insert the packing gland through the side opening of the bracket and over the end of the shaft. This gland cannot be installed with the rotor and shaft in place.

NOTE: Make sure the gland is installed square and nuts tightened evenly. Tighten nuts wrench tight and then back off until gland is slightly loose.

5. Coat the idler pin with light oil and place the idler and bushing on the idler pin in the head. If replacing a carbon graphite idler bushing see **“Installation of Carbon Graphite Bushings” page 11**.

6. Put the .010” to .015” thick head gasket on the head and install the head and idler assembly on the pump. The jacket head plate and gasket must be installed at this time (if your pump is equipped with this feature). Tighten the head capscrews.

7. Slide the inner bearing spacer collar over the shaft with recessed end toward the rotor. Q, QS and M bearing spacer collar is not recessed.

Place the pair of half round rings (not used on Q, QS and M) in the shaft and slide the inner spacer collar over them. **See Figure 4.**

8. Press the lip seal (lip toward end of shaft) into the inner end cap and insert the end cap through the shaft end of the bracket. With two fingers turn it clockwise (looking at end of shaft) until it engages the threads. The bosses on the end cap must be toward the rotor. Turn the end cap until it projects slightly into the opening on the side of the bracket.

NOTE: The end cap must be turned so far that the lip of the seal drops off the end of the spacer collar on the shaft or the end cap becomes disengaged with the threads. **See Figure 4.**

9. Pack the ball bearing with multi-purpose grease, place on the shaft and push or drive into place in the bracket.
10. Install the lip seal (lip toward end of shaft) and bearing spacer in the outer end cap and turn the end cap into the bracket until tight against the bearing. **See Figure 4.**
11. Put lockwasher and locknut on shaft. Insert length of hardwood or brass through port opening between rotor teeth to keep shaft from turning. Tighten locknut to 120-150 ft.- lbs. Torque (LS) or 170-190 ft. – lbs. Torque (Q, QS, M). Bend one tang of lockwasher into slot of locknut. If tang does not line up with slot, tighten locknut until it does. Failure to tighten locknut or engage lockwasher tang could result in early bearing failure and cause damage to rest of pump. Remove length of hardwood or brass from port opening.
12. Adjust the pump end clearance as in **“Thrust Bearing Adjustment”, page 11**.

DANGER !

Before starting pump, be sure all drive equipment guards are in place.

Failure to properly mount guards may result in serious injury or death.

PART 2 - MECHANICAL SEAL PUMPS

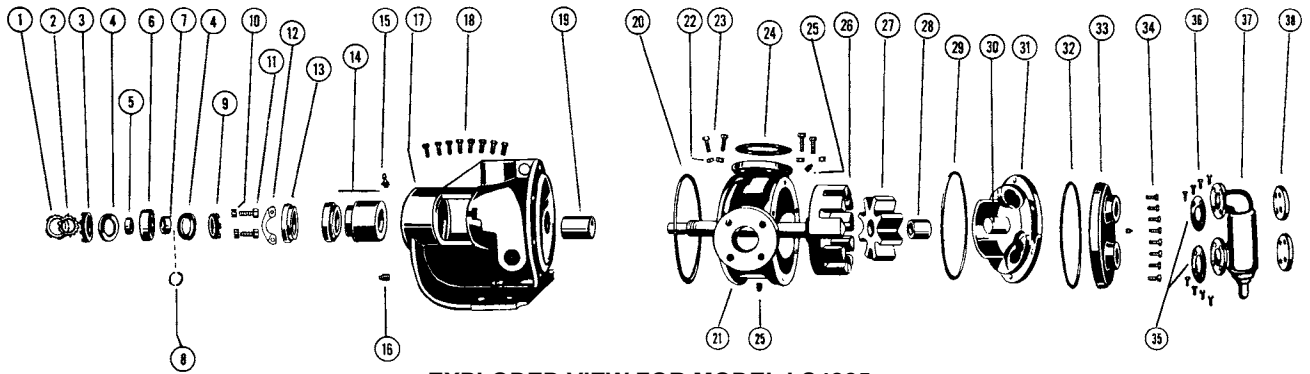

EXPLODED VIEW FOR MODEL LS4225

ITEM	NAME OF PART	ITEM	NAME OF PART	ITEM	NAME OF PART
1	Locknut	14	Mechanical Seal	27	Idler and Bushing
2	Lockwasher	15	Grease Fitting	28	Idler Bushing
3	End Cap (Outer)	16	Pipe Plug	29	Head Gasket
4	Lip Seal for End Cap	17	Bracket and Bushing	30	Idler Pin
5	Bearing Spacer Collar (Outer)	18	Capscrew for Bracket	31	Head and Idler Pin
6	Ball Bearing	19	Bracket Bushing	32	Gasket for Jacket Head Plate
7	Bearing Spacer Collar (Inner)	20	Bracket Gasket	33	Jacket Head Plate
8	Ring, Half Round	21	Casing	34	Capscrew for Head
9	End Cap (Inner)	22	Nut for Flanges	35	Capscrew for Relief Valve
10	Nut for Seal Holder	23	Capscrew for Flanges	36	Internal Relief Valve
11	Capscrew for Seal Holder	24	Pipe Flange Gasket	37	Cover Plate, Relief Valve
12	Seal Plate	25	Pipe Plug		
13	Seal Holder	26	Rotor and Shaft		

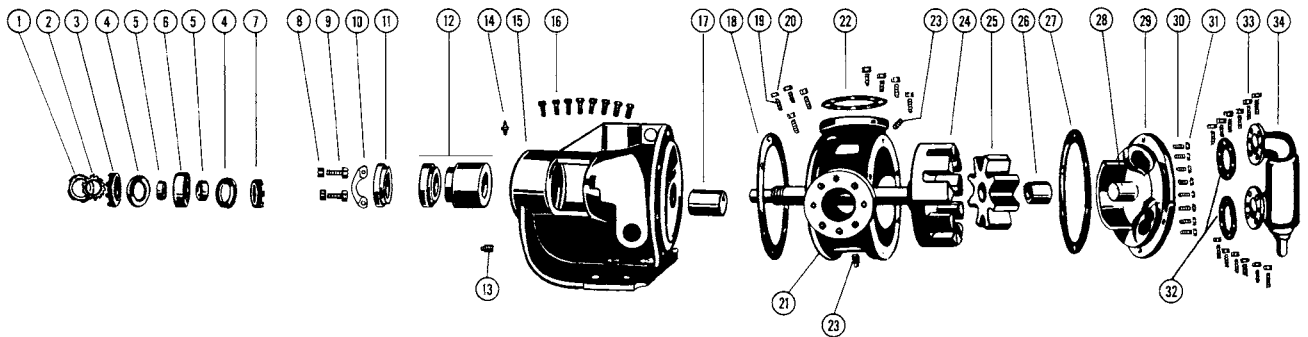

EXPLODED VIEW FOR MODELS Q, QS AND M4225

ITEM	NAME OF PART	ITEM	NAME OF PART	ITEM	NAME OF PART
1	Locknut	13	Pipe Plug	25	Idler and Bushing
2	Lockwasher	14	Grease Fitting	26	Idler Bushing
3	End Cap (Outer)	15	Bracket and Bushing	27	Head Gasket
4	Lip Seal for End Cap	16	Capscrew for Bracket	28	Idler Pin
5	Bearing Spacer Collar	17	Bracket Bushing	29	Head and Idler Pin
6	Ball Bearing	18	Bracket Gasket	30	Stud for Head
7	End Cap (Inner)	19	Stud for Flanges	31	Nut for Head
8	Nut for Seal Holder	20	Nut for Flanges	32	Relief Valve Gasket
9	Capscrew for Seal Holder	21	Casing (QS size has opposite ports)	33	Capscrew for Relief Valve
10	Seal Holder Plate	22	Pipe Flange Gasket	34	Internal Relief Valve
11	Seal Holder	23	Pipe Plug		
12	Mechanical Seal	24	Rotor and Shaft		

DISASSEMBLY

DANGER !

Before opening any Viking pump liquid chamber (pumping chamber, reservoir, relief valve adjusting cap fitting, etc.) Be sure:

1. That any pressure in the chamber has been completely vented through the suction or discharge lines or other appropriate openings or connections.
2. That the driving means (motor, turbine, engine, etc.) has been "locked out" or made non-operational so that it cannot be started while work is being done on pump.
3. That you know what liquid the pump has been handling and the precautions necessary to safely handle the liquid. Obtain a material safety data sheet (MSDS) for the liquid to be sure these precautions are understood.

Failure to follow above listed precautionary measures may result in serious injury or death.

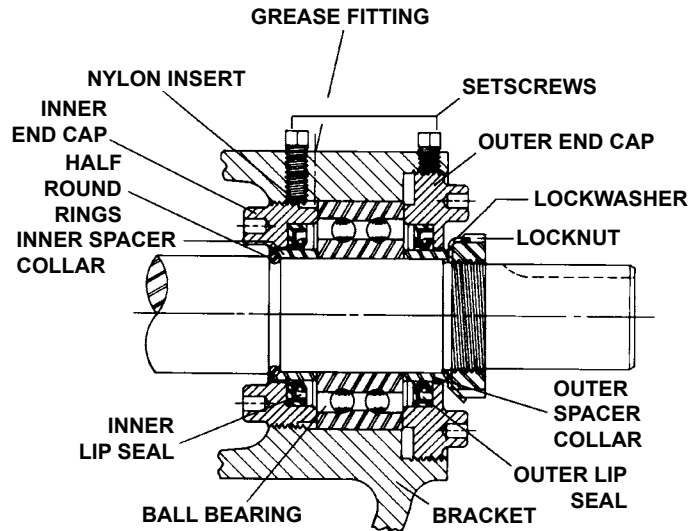

FIGURE 5

1. Mark head and casing before disassembly to make sure they are reassembled properly. Remove the head from the pump.

CAUTION: DO NOT ALLOW THE IDLER TO FALL FROM THE IDLER PIN.

Tilting the top of the head back as it is removed will prevent the idler from falling. Avoid damaging the head gasket if possible. If pump is furnished with a relief valve it need not be removed from the head or disassembled at this point (see page 11 for Valve Instructions). If the pump has a jacket head plate, this plate will separate from the head when the head is removed. The gasket for jacket head plate between the head and the jacket head plate should be removed and the gasket surfaces on the above parts cleaned. Disassembly will probably require replacement of the gasket for jacket head plate between the pump head and jacket head plate. These gaskets should be carried as spare parts for pumps thus equipped.

2. Remove the idler and bushing assembly.
3. Bend up tang of lockwasher and with a spanner wrench remove the locknut and lockwasher from the shaft. **NOTE:** A piece of hard wood or brass inserted in the casing port and between the rotor teeth will prevent the shaft from turning.

4. **STANDARD MECHANICAL SEAL** (Type 9, PTFE is standard). If the mechanical seal fails it can be replaced with a new one. There are two basic parts to the mechanical seal, the rotary member and the stationary seat. See Figure 8. To remove the mechanical seal loosen the setscrews around the outside of the mechanical seal which lock it to the shaft. Access to the seal setscrews is through the seal access hole located on the left hand side of the pump mounting bracket (viewed from the shaft end). See Figure 8. Rotate the rotor shaft so all setscrews come into view (three on Q, QS & M, four on LS). Remove the nuts holding the seal holder plate. Remove the seal holder and plate.

OPTIONAL MECHANICAL SEAL (Type 1 or equivalent single synthetic rubber bellows style). It uses a set collar behind the seal spring. See Figure 7. Two setscrews must be loosened before shaft can be removed. Access to the collar setscrews is through the seal access hole on the right hand side of the mounting bracket (viewed from the shaft end).

5. Tap the shaft toward head approximately 1/2 inch and check for a pair of half circle, round wire rings, under the inner bearing spacer collar. **NOTE:** These half rings must be removed before the rotor and shaft can be removed from the pump (these rings are not used in the Q, QS and M size pumps).
6. Carefully remove the rotor and shaft. As the shaft is being removed decreasing shaft diameters tend to allow the shaft to drop onto the bracket bushing. To avoid damaging the bracket bushing, support the rotor and do not allow either end of the shaft to tilt downward. **NOTE:** Considerable force may be required to remove the rotor and shaft from the pump. Be careful seal parts are not damaged as the rotor and shaft is removed.
7. The seal seat and rotary member of the seal can now be removed from the side opening of bracket.

8. Loosen the four setscrews over the outer and inner end caps. Remove both end caps, ball bearing and bearing spacer collars. **See Figure 5.** **NOTE:** The inner end cap can be removed through the side openings in the bracket.
9. Clean all parts thoroughly and examine for wear or damage. Check lip seals, ball bearing, bushings, and mechanical seal and replace as necessary. Check all other parts for nicks, burrs, excessive wear and replace if necessary. **NOTE:** Be sure shaft is free from burrs and foreign particles that might damage the bracket bushing. Scratches on the shaft in the seal area will provide leakage paths under the mechanical seal.
10. Check casing for wear or damage while mounted to the bracket.

ASSEMBLY

1. Install the bracket bushing (if carbon graphite, **see "Installation of Carbon Graphite Bushings" on page 11**).
2. Assemble the rotor and shaft in the bracket. Start the end of the shaft in the bracket bushing and turn from right to left slowly, pushing the rotor into the casing.
3. Coat the idler pin, in the head, with light oil and place the idler and bushing on the idler pin. If replacing a carbon graphite idler bushing **see "Installation of Carbon Graphite Bushings" on page 11**.
4. Put the head gasket on the head and install the head and idler assembly on the pump. Tighten the head capscrews or nuts.
5. **STANDARD MECHANICAL SEAL** (PTFE - **see Figure 8**.) The seal is simple to install and good performance will result if care is taken during installation.

NOTE: Never touch the sealing faces with anything but the fingers of a clean cloth.

Clean the rotor shaft and bracket seal housing bore. Make sure they are free of dirt, grit and scratches. Gently radius the leading edge of the shaft diameter over which the seal must be placed. A tapered sleeve is available, at extra cost, for the "Q, QS and M" pumps from Viking Pump Division for installation of the mechanical seal on the shaft as in **Figure 6**. The "LS" pump shaft is tapered and an installation sleeve is not available.

Coat the tapered sleeve and the inside of the rotary member with a generous quantity of SAE 30 non-detergent oil. Grease is not recommended. Start the rotary member on the shaft and over the tapered sleeve.

CAUTION: Some seals may be equipped with installation clips. These must be removed after seal is placed on the proper diameter portion of the shaft.

Move the rotary member so the setscrews are directly below the seal access holes on the left side of the bracket (viewed from the shaft end) - **see Figure 8**. Tighten all setscrews securely to the shaft. Flush the sealing faces of both the rotary member and seal seat with oil and install the seal seat and a seat gasket over the end of the shaft against the machined bracket face. Assemble the other seal seat gasket, seal holder, seal holder plate, capscrews and nuts and tighten securely. Remove the tapered installation sleeve.

OPTIONAL MECHANICAL SEAL (See Figure 7.)

Install the seal set collar - examine the set collar to be sure that there are no burrs or scratches and that the setscrews are withdrawn so that the shaft will

not be scratched when the set collar is installed. Place the set collar onto the shaft, push it into the seal chamber until the centerline of the setscrews coincides with the centerline of the tapped seal access holes on the right side of the bracket (viewed from the shaft end). Tighten all the setscrews in the set collar securely.

Install the rotating member of the seal - Slide the spring over the shaft into the seal chamber and onto the set collar pilot. Center the spring adapter (on Q, QS & M models only) against the back of the metal retainer so that the spring will push against the adapter and not work itself over the back of the mechanical seal. Place the tapered sleeve on the shaft as in **Figure 9**. Apply a liberal coating of SAE-30 lube oil to the large diameter portion of the rotor shaft, tapered sleeve and to the inside diameter of the mechanical seal rubber parts. Start the rotary member of seal with its carbon face out onto the rotor shaft and push it along the shaft until the spring is centered against the adapter.

Install the Stationary Seal Seat - Lubricate the outside diameter of the mechanical seal O-Ring seat gasket and flush the lapped face with lube oil. Press the stationary seat into the bore until the back, unlapped face, is just inside the bore. Position the stationary seat by installing the seal holder and secure the seal holder to the machined face of the bracket with the seal holder plate. Tighten the nuts securing the seal holder plate evenly so that the seal holder will not be distorted.

Remove the tapered installation sleeve.

COAT SHAFT AND TAPERED SLEEVE WITH LIGHT OIL BEFORE ASSEMBLY

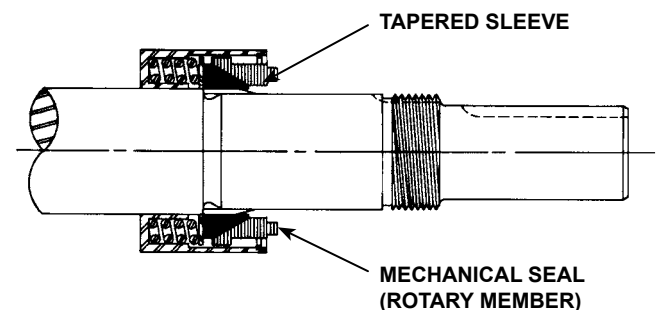

FIGURE 6

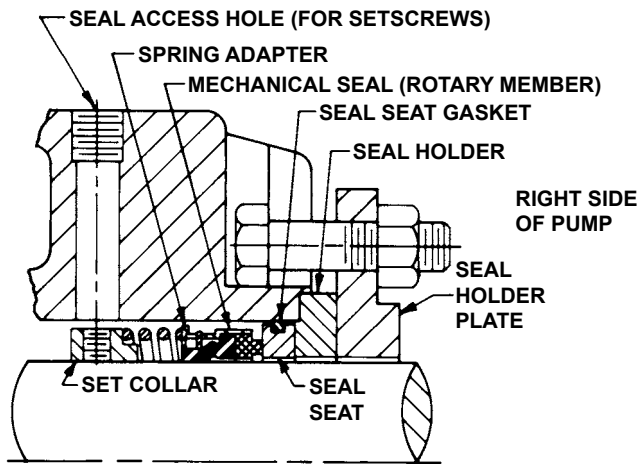

FIGURE 7 - OPTIONAL MECHANICAL SEAL

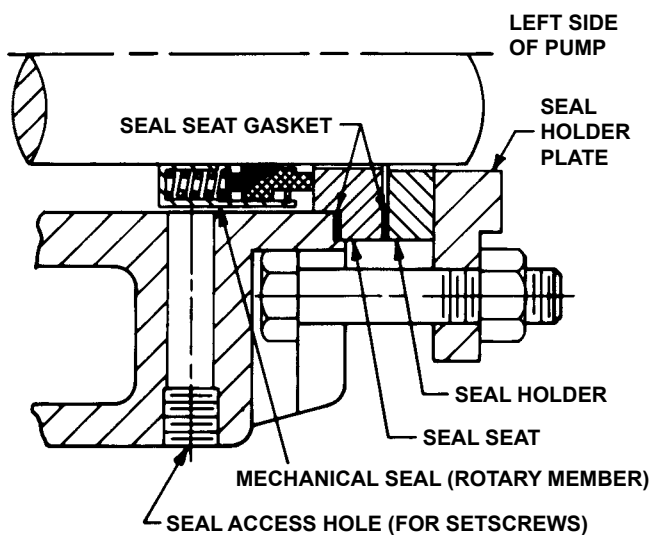

FIGURE 8 - STANDARD MECHANICAL SEAL

- Put lockwasher and locknut on shaft. Insert length of hardwood or brass through port opening between rotor teeth to keep shaft from turning. Tighten locknut to 120-150 ft.- lbs. Torque (LS) or 170-190 ft. - lbs. Torque (Q, QS, M). Bend one tang of lockwasher into slot of locknut. If tang does not line up with slot, tighten locknut until it does. Failure to tighten locknut or engage lockwasher tang could result in early bearing failure and cause damage to rest of pump. Remove length of hardwood or brass from port opening.

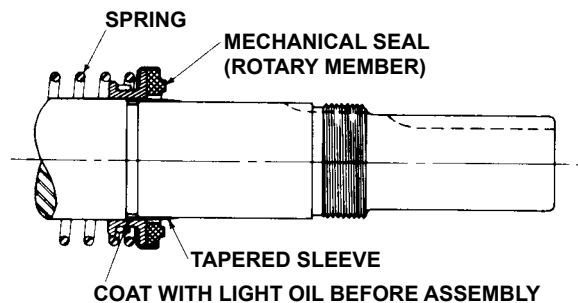

FIGURE 9

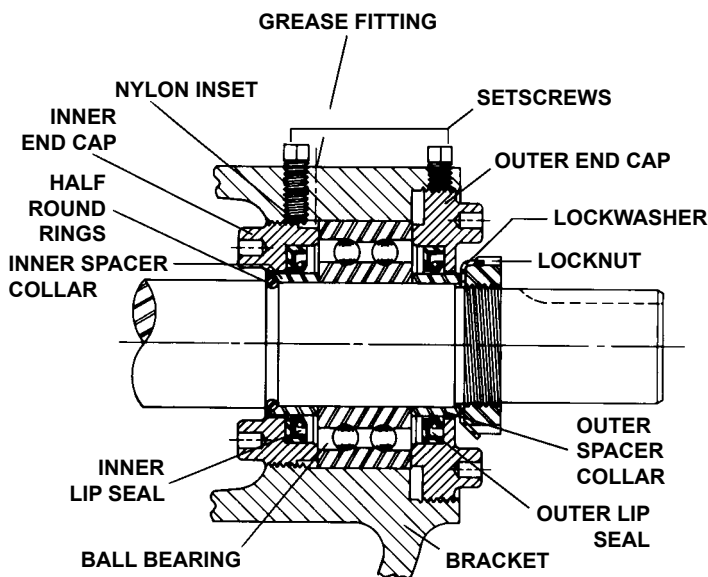

FIGURE 10

- Slide the inner bearing spacer collar over the shaft with recessed end toward rotor. **NOTE:** The pair of half round rings must be inserted in the groove in the shaft and then slide the spacer collar over them. See Figure 10 (not used on Q and M size pumps).
- Press the lip seal (lip toward end of shaft) into the inner end cap and insert the end cap through the shaft end of the bracket. With two fingers turn it clockwise (looking at end of shaft) until it engages the threads. The bosses on the end cap must be toward the rotor. Turn the end cap until it projects slightly into the opening on the side of the bracket. **NOTE:** The end cap must not be turned so far that the lip of the lip seal drops off the end of the spacer collar on the shaft or the end cap becomes disengaged with the threads. See Figure 10.
- Pack the ball bearing with multi-purpose grease, place on the shaft and push or gently drive into place in the bracket.
- Install the lip seal (lip toward end of shaft) and bearing spacer in the outer end cap and turn the end cap into the bracket until tight against the bearing. See Figure 10.

- Adjust the pump end clearance as in "Thrust Bearing Adjustment" (see Page 11).

DANGER !

Before starting pump, be sure all drive equipment guards are in place.

Failure to properly mount guards may result in serious injury or death.

THRUST BEARING ADJUSTMENT

See Figure 10.

1. Loosen the two setscrews over each of the outer and inner end caps.
2. Turn the inner end cap clockwise (viewed from shaft end) until it projects slightly into the opening on the side of the bracket exposing approx. three threads.
3. Turn the outer end cap clockwise until the rotor is tight against the head and the rotor shaft cannot be turned.
4. Make a reference mark on the bracket end, opposite a notch on the outer end cap. Back off the outer end cap the required number of notches as shown in the Total End Clearance Chart, see Figure 11. Each notch represents .002" end clearance.
5. High viscosity liquids require additional end clearances. The amount of extra end clearance depends on the viscosity of the liquid pumped. For specific recommendations consult the factory.
6. Tighten the inner end cap with a spanner wrench. Tap the spanner wrench lightly but **DO NOT OVER TIGHTEN** as it will damage the threads.
7. Tighten the set screws that hold the inner and outer end caps to prevent their turning in the bracket.
8. Check the rotor to determine if it turns freely; if it does not, add more end clearance.

TOTAL END CLEARANCE CHART		
PUMP SIZE	TURN OUTER END CAP COUNTER-CLOCKWISE NO. OF NOTCHES	TOTAL END CLEARANCE*
LS	5	.010
Q, QS AND M	7.5	.015

* Total End Clearance includes extra clearance for temperatures of 450°F.

FIGURE 11

INSTALLATION OF CARBON GRAPHITE BUSHINGS

When installing a new carbon graphite idler or bracket bushing, extreme care should be taken to prevent breaking, as it is a brittle material and easily cracked. If cracked the bushing will quickly disintegrate. **NOTE:** Using a lubricant and adding a chamfer on the bushing and the mating part will help in the installation of carbon graphite bushings.

An arbor press should always be used for installing carbon graphite bushings. Be sure bushing is started straight and **DO NO STOP** pressing operation until bushing is in proper position. Starting and stopping will invariably result in a cracked bushing.

Carbon graphite bushings with extra interference fits are frequently furnished for high temperature operation. These bushings must be installed by a shrink fit. Heat the bracket or idler to 750° and install cool bushings with an arbor press. (If facilities are not available for this temperature, it is possible to install with 450° temperature. However the lower the temperature the greater the possibility of cracking the bushing.) Check for additional information on high temperature applications see Engineering Service Bulletin ESB-3.

Check bushing for cracks after installation. Coat surface of the bushing with amyl acetate (banana oil). Let it evaporate, and any cracks will be visible wet streaks. If cracks appear, the bushing should be replaced. **CAUTION:** Amyl acetate is a flammable solvent and should be used with care.

SAFETY RELIEF VALVE INSTRUCTIONS

DISASSEMBLY

DANGER !

Before opening any Viking pump liquid chamber (pumping chamber, reservoir, relief valve adjusting cap fitting, etc.) Be sure:

1. That any pressure in the chamber has been completely vented through the suction or discharge lines or other appropriate openings or connections.
2. That the driving means (motor, turbine, engine, etc.) has been "locked out" or made non-operational so that it cannot be started while work is being done on pump.
3. That you know what liquid the pump has been handling and the precautions necessary to safely handle the liquid. Obtain a material safety data sheet (MSDS) for the liquid to be sure these precautions are understood.

Failure to follow above listed precautionary measures may result in serious injury or death.

NOTE: Mark valve and head before disassembly to insure proper reassembly.

1. Remove valve cap.
2. Measure and record the length of extension of the adjusting screw. **Refer to "A" on Figures 12 and 13.**
3. Loosen the locknut and back out adjusting screw until spring pressure is released.
4. Remove bonnet, spring guide, spring and poppet from valve body. Clean and inspect all parts for wear or damage and replace as necessary.

ASSEMBLY

Reverse the procedure outlined under disassembly.

If valve is removed for repairs, be sure to replace in same position. The valve cap should point towards the suction port.

DANGER !

Before starting pump, be sure all drive equipment guards are in place.

Failure to properly mount guards may result in serious injury or death.

PRESSURE ADJUSTMENT

If the pressure setting of the safety relief valve is to be changed from that which the factory has set, the following instructions should be carefully followed: Remove the valve cap which covers the adjusting screw, and loosen the lock nut which locks the adjusting screw so pressure setting will not change during operation of pump. A pressure gauge somewhere in the discharge line must be used for actual adjustment operation. The adjusting screw should be turned in for increasing the pressure or turned out for decreasing the pressure. With the discharge line closed at a point beyond the pressure gauge, the gauge will show the maximum pressure the valve will allow while pump is in operation.

IMPORTANT

In ordering parts for safety relief valve, always be sure to give model number and serial number of pump as it appears on nameplate and the name of the part wanted. When ordering springs, be sure also to give pressure setting desired.

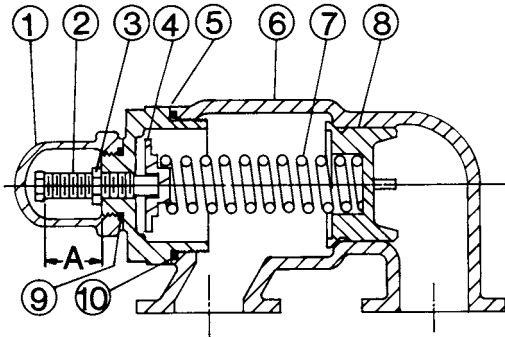

FIGURE 12
VALVE - LS, Q, QS AND M SIZES

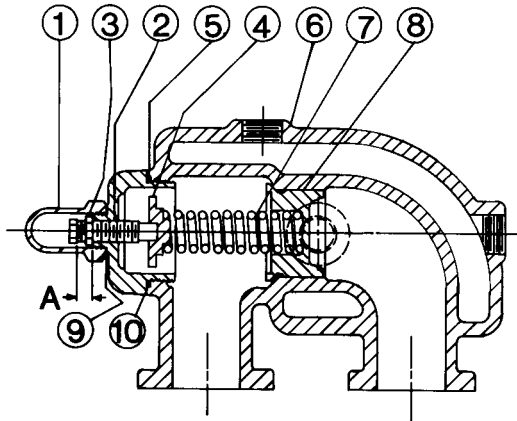

FIGURE 13
JACKETED VALVE - LS, Q, QS AND M SIZES

LIST OF PARTS

1. Valve Cap	6. Valve Body
2. Adjusting Screw	7. Valve Spring
3. Lock Nut	8. Poppet
4. Spring Guide	9. Cap Gasket
5. Bonnet	10. Bonnet Gasket

VIKING PUMP



WARRANTY

Viking warrants all products manufactured by it to be free from defects in workmanship or material for a period of one (1) year from date of startup, provided that in no event shall this warranty extend more than eighteen (18) months from the date of shipment from Viking. If, during said warranty period, any products sold by Viking prove to be defective in workmanship or material under normal use and service, and if such products are returned to Viking's factory at Cedar Falls, Iowa, transportation charges prepaid, and if the products are found by Viking to be defective in workmanship or material, they will be replaced or repaired free of charge, FOB. Cedar Falls, Iowa.

Viking assumes no liability for consequential damages of any kind and the purchaser by acceptance of delivery assumes all liability for the consequences of the use or misuse of Viking products by the purchaser, his employees or others. Viking will assume no field expense for service or parts unless authorized by it in advance.

Equipment and accessories purchased by Viking from outside sources which are incorporated into any Viking product are warranted only to the extent of and by the original manufacturer's warranty or guarantee, if any.

THIS IS VIKING'S SOLE WARRANTY AND IS IN LIEU OF ALL OTHER WARRANTIES, EXPRESSED OR IMPLIED, WHICH ARE HEREBY EXCLUDED, INCLUDING IN PARTICULAR ALL WARRANTIES OF MERCHANTABILITY OR FITNESS FOR A PARTICULAR PURPOSE. No officer or employee of IDEX Corporation or Viking Pump, Inc. is authorized to alter this warranty.