

Section	680
Page	680.1
Issue	H

FEATURES

① Differential Pressures	To 8.5 BAR To 125 PSI
② Temperature Range	-50°C. to +260°C. -60°F. to +500°F.
① Viscosity Range	1.0 cSt. to 5,500 cSt. 28 SSU to 25,000 SSU

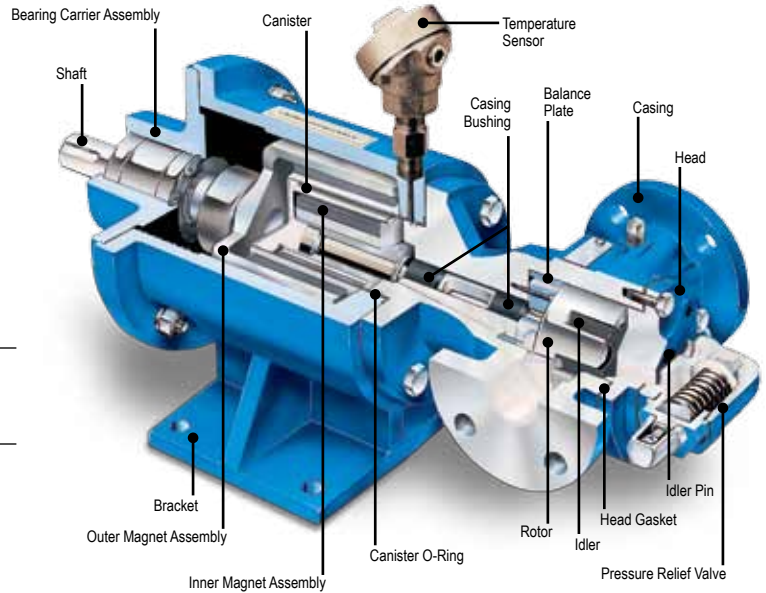

SERIES 897 Pumps
Cutaway View
“HL” size shown

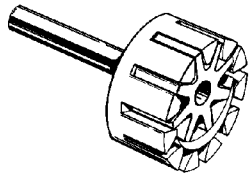

INTERNAL GEAR

Viking internal gear Mag Drive pumps are available in stainless steel, steel, or cast iron construction with capacities up to 75 GPM. With only two moving parts Viking Mag Drive and Viking's gear-within-a-gear principle provides low-shear pumping.

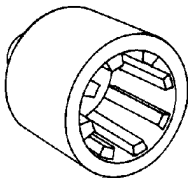

MAGNETIC COUPLING

Viking Mag Drive magnetically couples the pump to the driver. Magnetic force passing through a stainless steel canister is used to drive the inner coupling, eliminating the need for shaft seals.

GPM 7 to 75

③ (Nominal Rating)

Viking® Mag Drive is designed to provide positive-displacement pumping capability in those situations that require the highest assurance of liquid containment. Viking Mag Drive provides for the safe, trouble-free transfer of hazardous, EPA-regulated fluids without electronic monitoring as required with mechanical face-type shaft seals. Hard-to-seal liquids are also easily handled with the Viking Mag Drive which eliminates the high cost of mechanical seal replacement and repair. A variety of coupling sizes are available for flow requirements to 75 GPM. The torque-carrying ability of high-strength magnets allows pumps to be coupled with gear reducers for slow-speed handling of viscous liquids. The self-priming positive-displacement pumping principle provides low-shear, nonpulsating flow. Internal gear pumps are available in stainless steel, steel, and cast iron construction.

- ① See following pages and performance curves, which can be electronically generated with the Viking Pump Selector Program, located on www.vikingpump.com for specific recommendations. Certain models have lower limitations.
- ② Optional samarium cobalt magnets are used at temperatures over 225°F.
- ③ Nominal capacities based on handling thin liquids at low pressures.

Kalrez®- Registered trademark of DuPont Performance Elastomers.
Viton®- Registered trademark of DuPont Performance Elastomers.
Viking® and Viking Mag Drive®- Registered trademarks of Viking Pump, Inc.

Section	680
Page	680.2
Issue	H

VIKING MAG DRIVE[®]

SERIES 897, 893 AND 895

INTERNAL GEAR

CONSTRUCTION—SERIES 897 (STAINLESS STEEL)—SERIES 893 (STEEL) AND SERIES 895 (CAST IRON)

Pump Construction	① O-Ring	Casing	Head	Rotor	Idler	Balance Plate	Rotor Shaft	Idler Pin	Idler Bushing	Internal Pressure Relief Valve
Stainless Steel	PTFE	Stainless Steel	Stainless Steel	Stainless Steel	③ PPS	PPS	Coated Stainless Steel	Coated Stainless Steel	Carbon Graphite	Stainless Steel
Steel	Buna-N	Steel	Steel	② Ductile Iron	③ PPS	PPS	Steel	Steel	Carbon Graphite	Steel Externals
Cast Iron	Buna-N	Iron	Iron	② Ductile Iron	③ PPS	PPS	Steel	Steel	Carbon Graphite	Iron

SPECIFICATIONS—SERIES 897, 893 AND 895

Model Numbers	Materials of Construction	Port Size Inches	Nominal Pump Rating			④ Magnetic Coupling Availability			⑤ Maximum Temperature (Standard Construction)		Maximum Hydrostatic Pressure		Approximate Pump Shipping Weight With Valve (Less Power)		⑦ Approximate Coupling Only Shipping Weight (ready to accept but less power)	
						Series	Torque		Degrees F.	Degrees C.						
							Ft-Lbs	Nm								
GG-897	Stainless Steel	1	10	2.3	1800	MD-A	4	5.4	225	93	400	28	22	10	31	14
GG-893	Steel															
GG-895	Cast Iron															
HJ-897	Stainless Steel	1½	20	4.5	1800	MD-A	4	5.4	225	93	400	28	30	14	31	14
HJ-893	Steel															
HJ-895	Cast Iron															
HL-897	Stainless Steel	1½	30	6.8	1800	MD-B	15	20.3	225	93	400	28	30	14	71	32
HL-893	Steel															
HL-895	Cast Iron															
AS-897	Stainless Steel	⑥ 3	35	8.0	1200	MD-B	15	20.3	225	93	400	28	78	35	71	32
AS-893	Steel															
AS-895	Cast Iron															
AK-897	Stainless Steel	⑥ 3	50	11	1200	MD-B	40	54	225	93	400	28	78	35	71	32
AK-893	Steel															
AK-895	Cast Iron															
AL-897	Stainless Steel	3	75	17	1200	MD-C	80	108	225	93	400	28	78	35	95	43
AL-893	Steel															
AL-895	Cast Iron															

① Buna-N, Viton[®], Neoprene, PTFE, or Kalrez[®] O-Rings available.

② Standard construction includes iron rotor for "GG" and "HJ" sizes; ductile iron rotor for "HL" through "AL" sizes. When steel-fitted construction is required, hardened steel rotor will be provided on "GG" through "HJ" sizes.

③ Standard Material is Polyphenylene Sulfide with composite material. Recommend using metal idler above 10,000 SSU.

④ See Performance Curves, which can be electronically generated with the Viking Pump Selector Program, located on www.vikingpump.com/pumpselector, for specific coupling recommendation on other pressures and viscosities. See page 13 for "Selecting the correct Mag Drive coupling."

⑤ Higher temperatures can be handled with Samarium Cobalt magnets. See page 20 for torque and temperature limits.

⑥ "AS" and "AK" Series 895 have 2½" NPT tapped ports.

⑦ For bearing carrier weights add 8 lbs (2 KG) for "MD-A" size, add 17 lbs (4 KG) for "MD-B" size.

DRIVE OPTIONS



SERIES 895 Pumps
MD-B15B, bearing carrier, footed bracket, and mounted pump with tapped ports.



SERIES 895 Pumps
MD-B15M, motor direct connected to bracket and pump with tapped ports.

Dimensions for Internal Gear Mag Drive Pumps - See Pages 680.3 through 680.12.

DIMENSIONS

These dimensions are average and not for construction purposes. Certified prints on request.

For specifications, see page 680.2.

DIMENSIONS—
SERIES 893
STEEL UNMOUNTED PUMPS
“GG”–“HJ”–“HL” SIZES

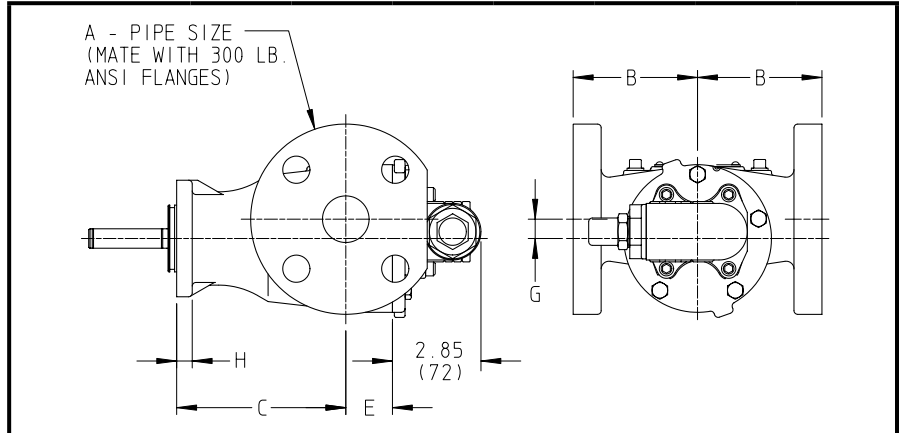

MODEL NO.	(in)		B	C	E	G	H
GG-893	1	in	4.00	4.29	1.12	0.62	0.50
		mm	102	108	29	16	13
HJ-893 HL-893	1½	in	4.00	5.44	1.50	0.62	0.50
		mm	102	138	38	16	13

For specifications, see page 680.2.

DIMENSIONS—
SERIES 895
CAST IRON UNMOUNTED
PUMPS
“GG”–“HJ”–“HL” SIZES

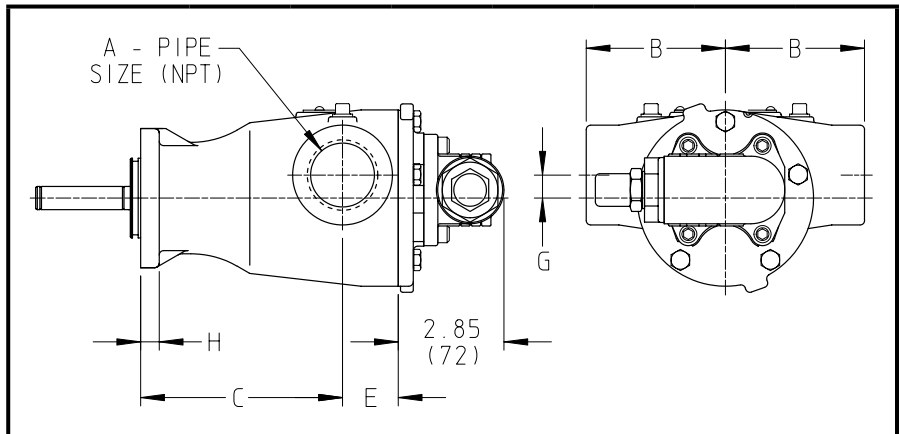

MODEL NO.	(in)		B	C	E	G	H
GG-895	1	in	2.75	4.29	1.12	0.62	0.50
		mm	70	108	29	16	13
HJ-895 HL-895	1½	in	3.75	5.44	1.50	0.62	0.50
		mm	95	138	38	16	13

Section	680
Page	680.4
Issue	H

VIKING MAG DRIVE[®]

SERIES 897 AND 895

STAINLESS STEEL AND CAST IRON CONSTRUCTION

DIMENSIONS

These dimensions are average and not for construction purposes. Certified prints on request.

For specifications, see page 680.2.

DIMENSIONS— SERIES 897 STAINLESS STEEL UNMOUNTED PUMPS “GG”–“HJ”–“HL” SIZES

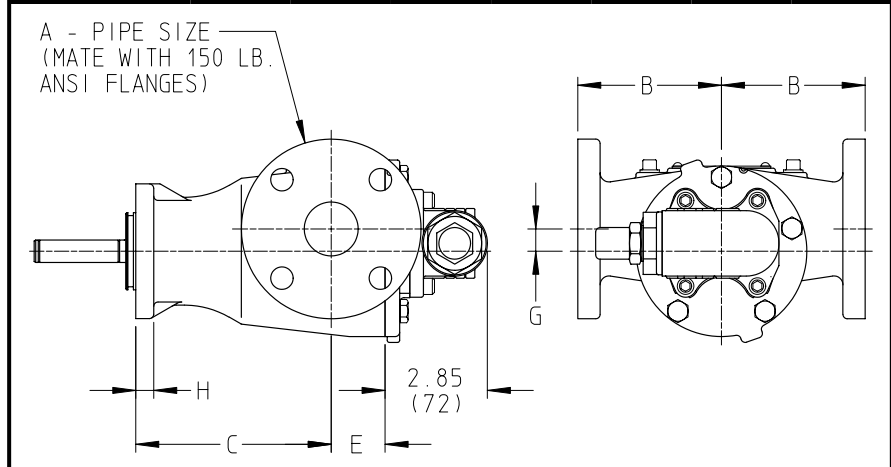

MODEL NO.	(in) A		B	C	E	G	H
GG-897	1	in	4.00	4.29	1.12	0.62	0.50
		mm	102	108	29	16	13
HJ-897 HL-897	1½	in	4.00	5.44	1.50	0.62	0.50
		mm	102	138	38	16	13

For specifications, see page 680.2.

DIMENSIONS— SERIES 895 (MD-A_“B” DRIVE) “GG”–“HJ”–“HL” SIZES

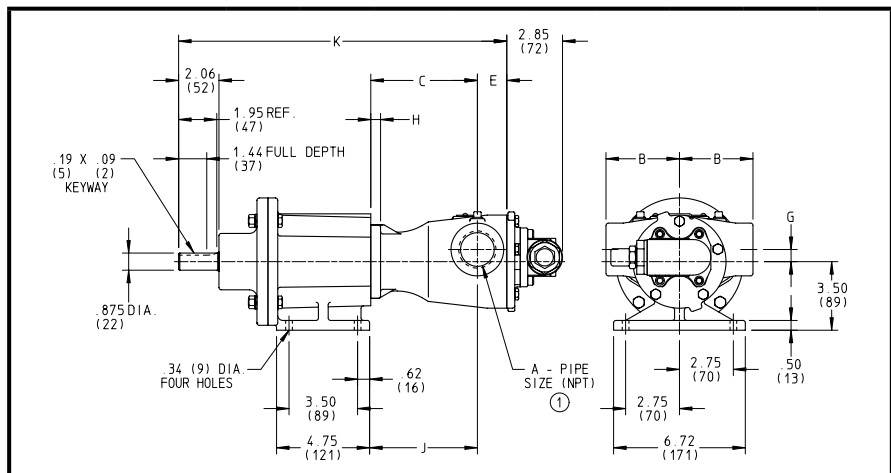

MODEL NO.	(in) A		B	C	E	G	H	J	K
GG-895-MD-A_B	1	in	2.75	4.29	1.12	0.62	0.50	4.35	15.30
		mm	70	108	29	16	13	123	389
HJ-895-MD-A_B HL-895-MD-A_B	1½	in	3.75	5.44	1.50	0.62	0.50	5.50	16.75
		mm	95	138	38	16	13	140	425

① Series 895 shown. See unmounted pump for port configuration on Series 893 and 897 pumps.

DIMENSIONS

These dimensions are average and not for construction purposes. Certified prints on request.

For specifications, see page 680.2.

**DIMENSIONS—
 SERIES 895
 (MD-B_“B” DRIVE)
 “HJ”–“HL” SIZES**

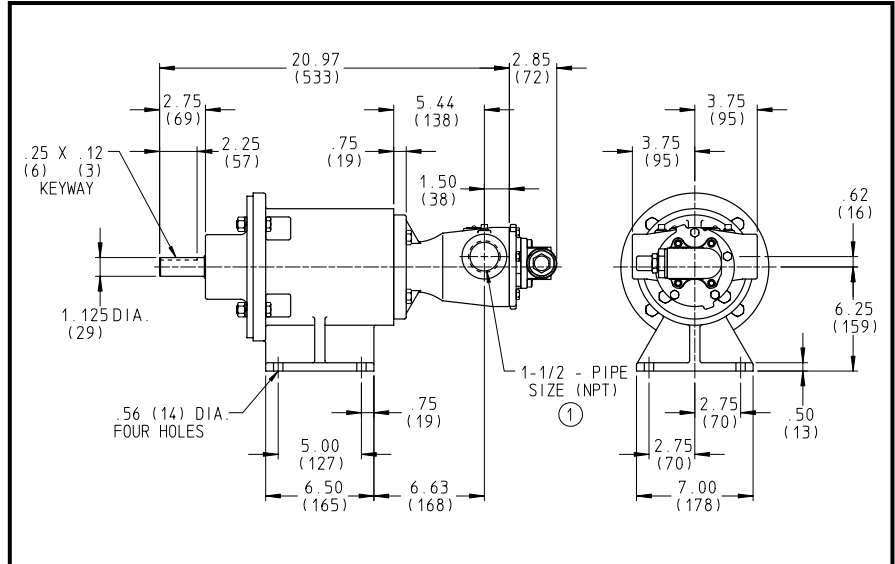

① Series 895 shown. See unmounted pump for port configuration on Series 893 and 897 pumps.

For specifications, see page 680.4.

**DIMENSIONS—
 SERIES 895
 (MD-A AND MD-B_“M” DRIVE)
 “GG”–“HJ”–“HL” SIZES**

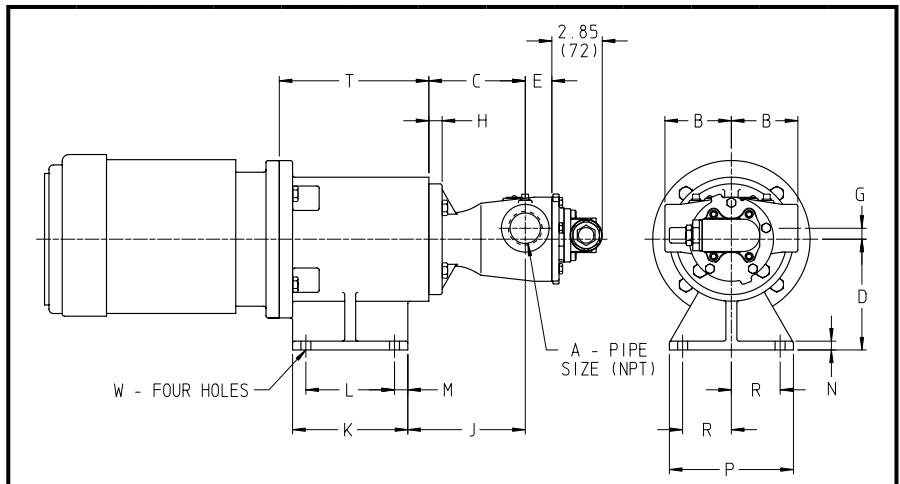

① Series 895 shown. See unmounted pump for port configuration on Series 893 and 897 pumps.

MODEL NO.	(in)		B	C	D	E	G	H	J	K	L	M	N	P	R	T	W
GG-895-MD-A_M	1	in	2.75	4.29	3.50	1.12	0.62	0.50	4.85	4.75	3.50	0.62	0.50	6.72	2.75	5.25	0.34
		mm	70	108	89	29	16	13	123	121	89	16	16	171	70	133	9
HJ-895-MD-A_M HL-895-MD-A_M	1½	in	3.75	5.44	3.50	1.50	0.62	0.50	5.50	4.75	3.50	0.62	0.50	6.72	2.75	5.25	0.34
		mm	95	138	159	38	16	13	140	121	89	16	13	171	70	133	9
HJ-895-MD-B_M HL-895-MD-B_M	1½	in	3.75	5.44	6.25	1.50	0.62	0.75	6.63	6.50	5.00	0.75	0.50	7.00	2.75	8.44	0.56
		mm	95	138	159	38	16	13	164	165	127	19	13	178	70	210	14

Section	680
Page	680.6
Issue	H

VIKING MAG DRIVE[®]

SERIES 893 AND 895

STEEL AND CAST IRON CONSTRUCTION

DIMENSIONS

These dimensions are average and not for construction purposes. Certified prints on request.

For specifications, see page 680.2.

DIMENSIONS— SERIES 893 STEEL UNMOUNTED PUMPS “AS”–“AK”–“AL” SIZES

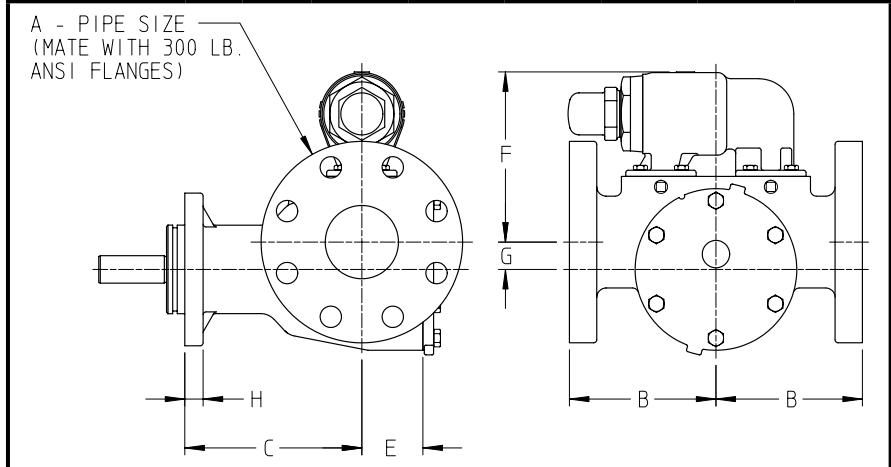

MODEL NO.	(in)							
		A	B	C	E	F	G	H
AS-893 AK-893	3	in	6.00	7.50	2.00	7.00	1.12	0.75
		mm	152	190	51	178	29	19
AL-893	3	in	6.00	7.25	2.50	7.00	1.12	0.75
		mm	152	184	63	178	29	19

For specifications, see page 680.2.

DIMENSIONS— SERIES 895 CAST IRON UNMOUNTED PUMPS “AS”–“AK”–“AL” SIZES

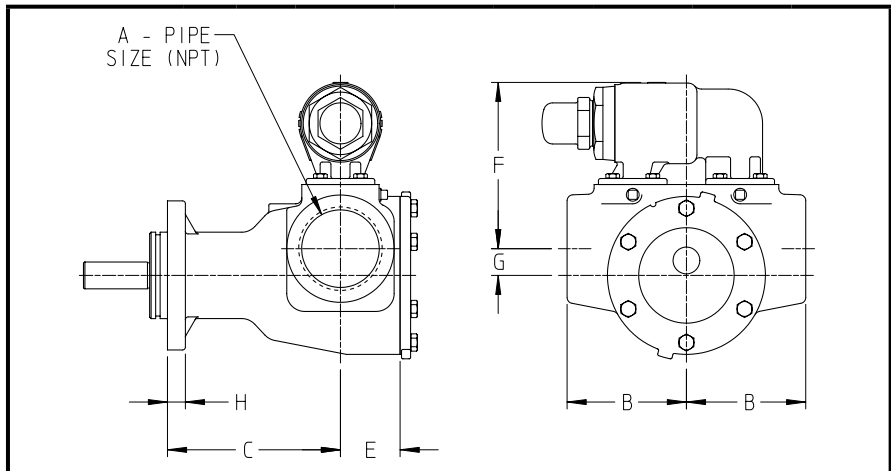

MODEL NO.	(in)							
		A	B	C	E	F	G	H
AS-895 AK-895	2½	in	5.00	7.50	2.00	7.00	1.12	0.75
		mm	127	190	51	178	29	19
AL-895	3	in	5.00	7.25	2.50	7.00	1.12	0.75
		mm	127	184	63	178	29	19

VIKING **MAG DRIVE**[®]
SERIES 897 AND 895
STAINLESS STEEL AND CAST IRON CONSTRUCTION

Section	680
Page	680.7
Issue	H

DIMENSIONS

These dimensions are average and not for construction purposes. Certified prints on request.

For specifications, see page 680.2.

DIMENSIONS—
SERIES 897
STAINLESS STEEL
UNMOUNTED PUMPS
“AS”–“AK”–“AL” SIZES

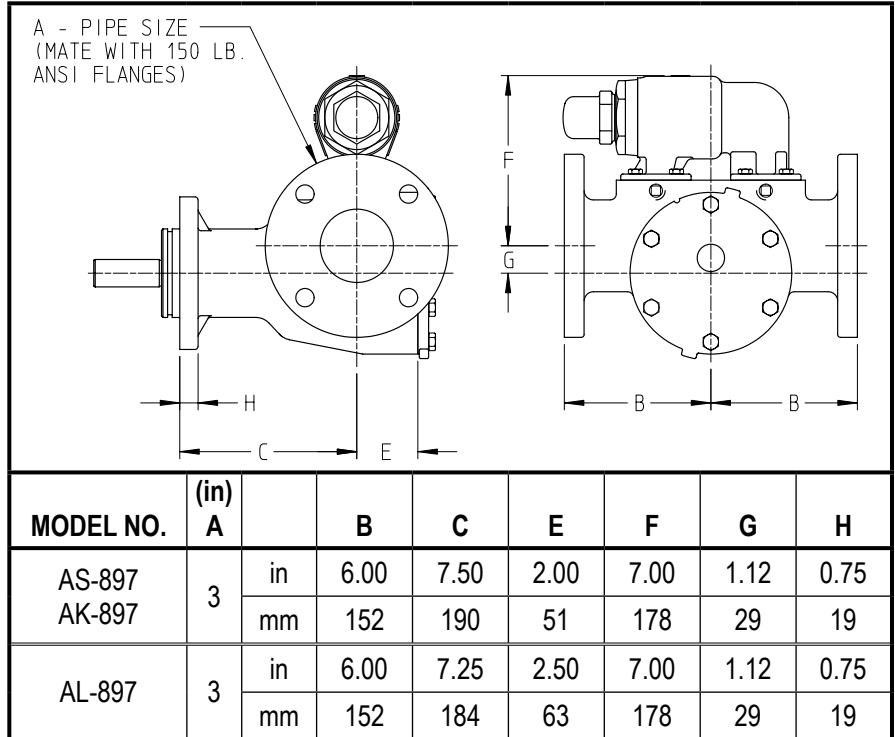

For specifications, see page 680.2.

DIMENSIONS—
SERIES 895
(MD-B_ “B” DRIVE)
“AS”–“AK”–“AL” SIZES

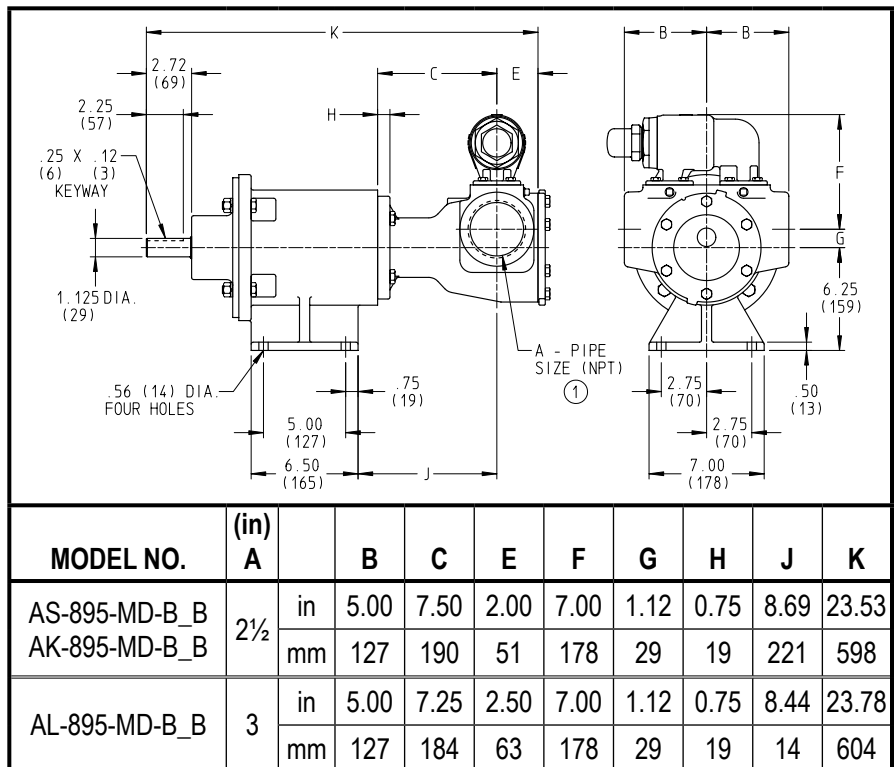

① Series 895 shown. See unmounted pump for port configuration on Series 893 and 897 pumps.

Section	680
Page	680.8
Issue	H

VIKING MAG DRIVE[®]

SERIES 895

CAST IRON CONSTRUCTION

DIMENSIONS

These dimensions are average and not for construction purposes. Certified prints on request.

For specifications, see page 680.2.

DIMENSIONS— SERIES 895 (MD-B_“M” DRIVE) “AS”–“AK”–“AL” SIZES

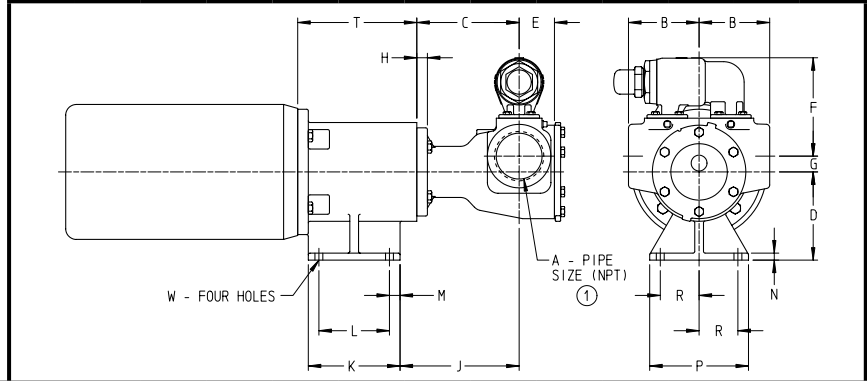

① Series 895 shown. See unmounted pump for port configuration on Series 893 and 897 pumps.

MODEL NO.	(in) A		B	C	D	E	F	G	H	J	K	L	M	N	P	R	T	W
AS-895-MD-B_M	2½	in	5.00	7.50	6.25	2.00	7.00	1.12	0.75	8.69	6.50	5.00	0.75	0.50	7.00	2.75	8.44	0.56
AK-895-MD-B_M		mm	127	190	159	51	178	29	19	221	165	127	19	13	178	70	214	14
AL-895-MD-B_M	3	in	5.00	7.25	6.25	2.50	7.00	1.12	0.75	8.44	6.50	5.00	0.75	0.50	7.00	2.75	8.44	0.56
		mm	127	184	159	63	178	29	19	214	165	127	19	13	178	70	214	14

For specifications, see page 680.2.

DIMENSIONS— SERIES 895 (MD-C80 “B” DRIVE) “AS”–“AK”–“AL” SIZES

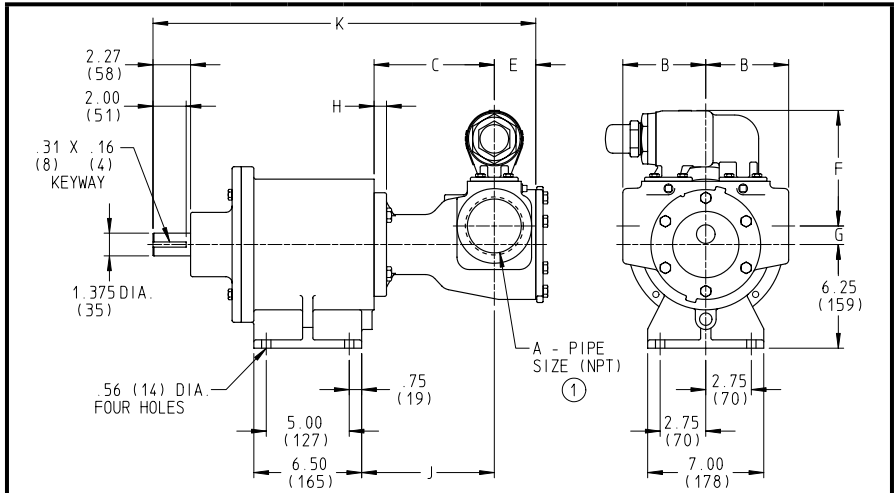

① Series 895 shown. See unmounted pump for port configuration on Series 893 and 897 pumps.

MODEL NO.	(in) A		B	C	E	F	G	H	J	K
AS-895-MD-C80-B	2½	in	5.00	7.50	2.00	7.00	1.12	0.75	8.25	22.83
AK-895-MD-C80-B		mm	127	190	51	178	29	19	210	580
AL-895-MD-C80-B	3	in	5.00	7.25	2.50	7.00	1.12	0.75	8.00	23.08
		mm	127	184	63	178	29	19	203	586

DIMENSIONS

These dimensions are average and not for construction purposes. Certified prints on request.

For specifications, see page 680.2.

**DIMENSIONS—
 SERIES 895
 (MD-A_ AND MD-B_“R” DRIVE)
 “GG”–“HJ”–“HL” SIZES
 “A” SIZE REDUCER UNITS**

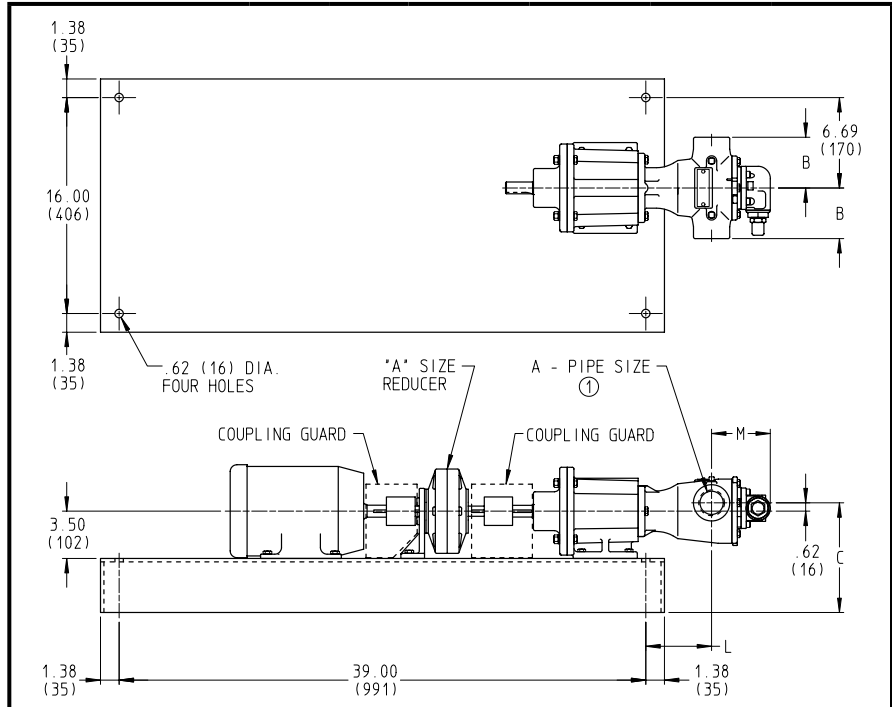

MODEL NO.	(in) A		B	C	L	M
GG-895-MD-A_R	1	in	2.75	8.12	3.73	4.29
		mm	70	206	95	108
HJ-895-MD-A_R HL-895-MD-A_R	1½	in	3.75	8.12	4.88	5.44
		mm	95	206	124	138
HJ-895-MD-B_R HL-895-MD-B_R	1½	in	3.75	10.87	6.00	5.44
		mm	95	276	152	138

① Series 895 shown. See unmounted pump for port configuration on Series 893 and 897 pumps.

Section	680
Page	680.10
Issue	H

VIKING MAG DRIVE[®]

SERIES 895

CAST IRON CONSTRUCTION

DIMENSIONS

These dimensions are average and not for construction purposes. Certified prints on request.

For specifications, see page 680.2.

DIMENSIONS— SERIES 895 (MD-B_“R” DRIVE) “AS”-“AK”-“AL” SIZES “A” SIZE REDUCER UNITS

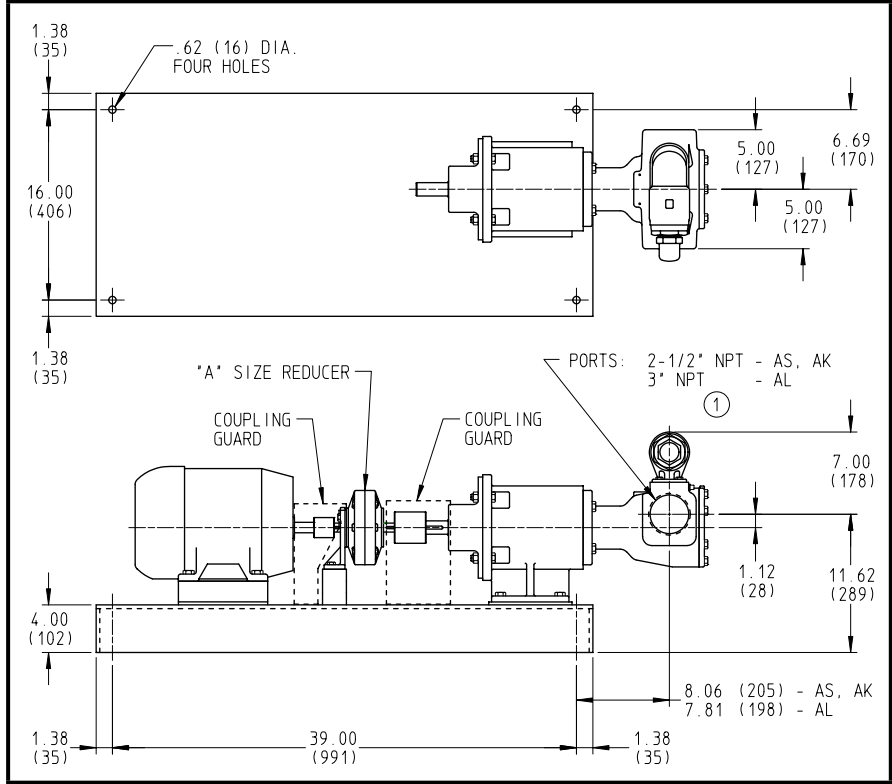

① Series 895 shown. See unmounted pump for port configuration on Series 893 and 897 pumps.

For specifications, see page 680.2.

DIMENSIONS— SERIES 895 (MD-B_“R” DRIVE) “AS”-“AK”-“AL” SIZES “B” SIZE REDUCER UNITS

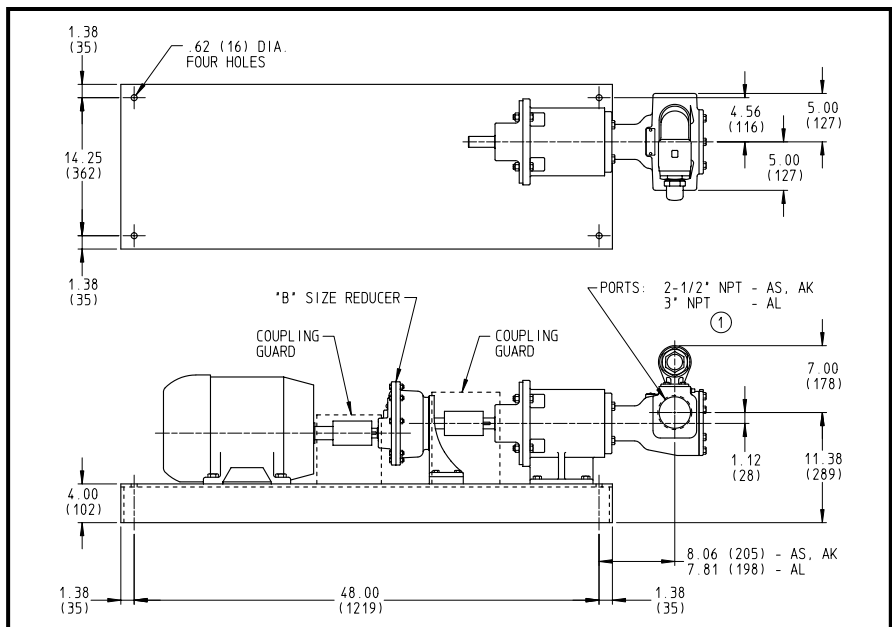

① Series 895 shown. See unmounted pump for port configuration on Series 893 and 897 pumps.

VIKING **MAG DRIVE**[®]
SERIES 895
CAST IRON CONSTRUCTION

Section	680
Page	680.11
Issue	H

DIMENSIONS

These dimensions are average and not for construction purposes. Certified prints on request.

For specifications, see page 680.2.

DIMENSIONS—
SERIES 895
(MD-C80 “R” DRIVE)
“AS”–“AK”–“AL” SIZES
“B” SIZE REDUCER UNITS

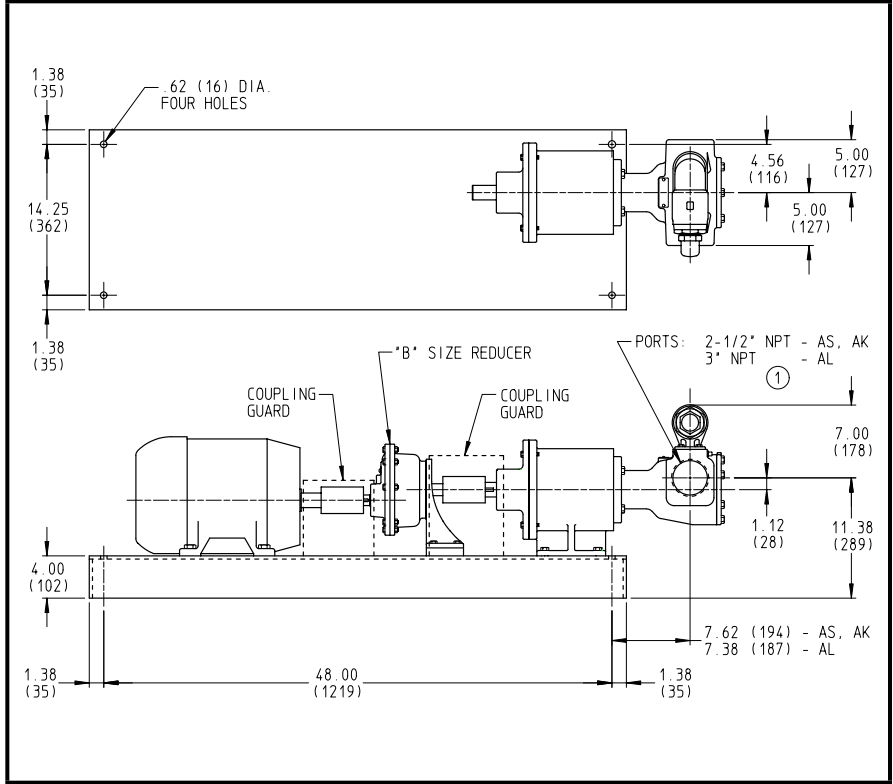

① Series 895 shown. See unmounted pump for port configuration on Series 893 and 897 pumps.

For specifications, see page 680.2.

DIMENSIONS—
SERIES 895
(MD-C80 “D” DRIVE)
“AS”–“AK”–“AL” SIZES

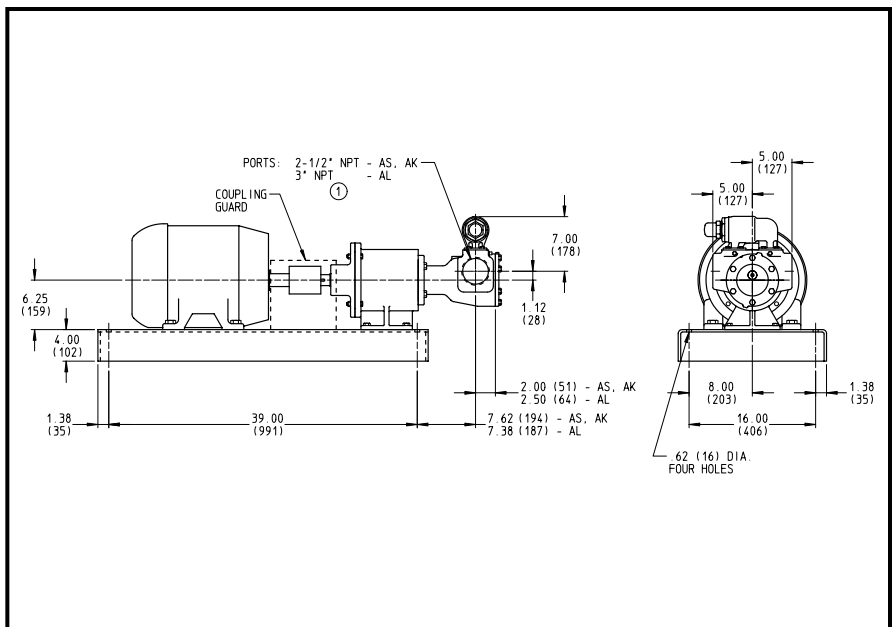

① Series 895 shown. See unmounted pump for port configuration on Series 893 and 897 pumps.

Section	680
Page	680.12
Issue	H

Performance Curve Notes

Printed performance curves are not available.

Performance curves can be electronically generated with the Viking Pump Selector Program.

This program can be located on www.vikingpump.com/pumpselector for the general public.

For authorized distributors, this program can be found listed under the “Products” tab at www.idexconnect.com.

Security passwords are required to access IDEXconnect.

INLET CONDITIONS: The performance curves show “Based on 10 (or 15) In.-Hg.” which is Viking’s standard test condition. This is not the maximum vacuum capability of the pump.

NPSH (Net Positive Suction Head): The NPSH_R (Net Positive Suction Head—Required by the pump) is given in the table below and applies for viscosities through 750 SSU. NPSH_A (Net Positive Suction Head—Available in the system) must be greater than NPSH_R.

NPSH_R—FEET OF LIQUID SP. GR. 1.0),
Viscosities to 750 SSU

Pump Size	PUMP SPEED					
	840	780	950	1150	1450	1750
GG	2.2	2.6	3.1	3.9	5.6	7.6
HJ, HL	2.8	3.4	4.5	6.2	9.5	13.5
AS, AK, AL	3.9	5.5	7.7	11.2	—	—

For a complete explanation of NPSH, see Viking Application Data Sheet, AD-19.

FOR VISCOSITIES ABOVE 750 SSU (NPSH_R data not available): The performance curves are based on 15 In.-Hg. While vacuums up to 20 In.-Hg. will not generally result in any loss of capacity, it is recommended that the suction line size and possibly the pump port size be increased to hold the expected vacuum to 15 In.-Hg. or less. Vacuum above 20 In.-Hg. should be avoided. (Refer to Viking’s General Catalog, Engineering Section 510, for information in determining line size).

THIN LIQUIDS: The 28 SSU curves should be used when applying these pumps to such liquids as cool water, aqueous solutions, alcohols, solvents, etc.

MECHANICAL EFFICIENCY: The Mechanical Efficiency (expressed in percent) can be calculated using the following formula:

$$\text{Mechanical Efficiency} = \frac{(\text{Differential Pressure, PSI})}{(\text{Capacity, GPM}) (100)} \frac{(\text{Horsepower, BHP})}{(1715)}$$

METRIC CONVERSION: The following table has been compiled for conversion to metric values.

Vacuum		Pressure		Capacity	
In.-Hg (Inches-Mercury)	kPa* (Kilopascal)	PSI (lbf/n.)	kPa* (Kilopascal)	GPM (Gal./min.)	L/min. (Litre/min)
1	3.4	1	6.9	1	3.8
5	17	25	172	0.26	1
10	34	50	345	—	—
15	51	100	690	—	—
20	68	150	1034	—	—
25	85	200	1379	—	—
—	—	250	1724	—	—

* 100 kPa = 1 bar

MAG DRIVE MODEL NUMBERS: In the Viking internal gear model number system, the basic size letters are combined with the series number (893, 895, 897) indicating basic pump construction material. (Steel, cast iron, stainless steel). Spur gear pumps models are available in cast iron construction (SG-804, 805, 807). and ductile iron (SGN-805, SGN-807).

Unmounted Pumps	UNITS
SG-804, 805, 807 SGN-805, SGN-807	Units are designated by the unmounted pump model numbers followed by the magnetic coupling size and a letter indicating drive style: D - Direct Drive M - “C” Face Motor Mount B - Bearing Carrier Assembly R - Viking Reducer Drive P - Commercial Reducer Drive (Examples: HJ-895-MD-A-R SG-80741-MD-A-B)
GG-893, 895, 897	
HJ-893, 895, 897	
HL-893, 895, 897	
AS-893, 895, 897	
AK-893, 895, 897	
AL-893, 895, 897	

Performance Curve Notes Cont'd

SELECTING THE CORRECT VIKING MAG DRIVE® COUPLING

1. Find pump HP and speed from performance curves, which can be electronically generated with the Viking Pump Selector Program, located on www.vikingpump.com/pumpselector.

2. Calculate application torque (T), using this formula:

$$T \text{ (FT LB)} = \frac{\text{HP}}{\text{SPEED}} \times 5252$$

3. Select temperature correction factor (TCF) from Table 1 or Table 2.

STANDARD NEODYMIUM MAGNETS (For Application Temperatures Below 225°F.)							
Application Temp. (°F)	AMB	100	125	150	175	200	225
TCF	1.0	.94	.88	.82	.76	.70	.64

Table 1: Temperature Correction Factors

OPTIONAL SAMARIUM COBALT MAGNETS (For Application Temperatures Above 225°F.)					
Application Temp. (°F)	175	200	300	400	500
TCF	.74	.73	.69	.63	.59

Table 2: Temperature Correction Factors

4. Divide calculated application torque by TCF to get adjusted application torque.

Select coupling with capacity equal to or greater than "adjusted application torque" from Table 3.

MAGNETIC COUPLING TORQUE CAPACITY TABLE	
① Coupling Size	Torque (FT-LBS)
MD-A4	4
MD-A9	9
MD-B15	15
MD-B40	40
MD-C80	80

Table 3

① Maximum speed on MD-A is 1750 RPM.. Other couplings are limited to 1150 RPM.

EXAMPLE 1:

1. A GG-895 is required to pump a 100 SSU liquid at 1750 RPM, 50 psi differential pressure. Temperature is 100° F.

From the Viking Pump Selector Program, located at www.vikingpump.com/pumpselector, the required HP is .85.

2. Calculate torque (T).

$$\begin{aligned} \text{TORQUE (T)} &= \frac{.85}{1750} (5252) \\ &= 2.6 \text{ FT LB} \end{aligned}$$

3. From the temperature correction factor table, the correction factor (TCF) = .94.

4. Calculate adjusted application torque.

$$\begin{aligned} \text{ADJUSTED APPLICATION TORQUE} &= \frac{2.6}{.94} \\ &= 2.8 \text{ FT-LB} \end{aligned}$$

5. Select coupling.

A STANDARD NEODYMIUM MD-A4 COUPLING IS THE PROPER SELECTION.

EXAMPLE 2:

1. An AL-895 is required to pump a 38 SSU liquid at 1150 RPM, 50 psi differential pressure. Temperature is 300° F

From the Viking Pump Selector Program, located at www.vikingpump.com/pumpselector, the required HP is 3.7.

2. Calculate torque (T).

$$\begin{aligned} \text{TORQUE (T)} &= \frac{3.7}{1150} (5252) \\ &= 16.9 \text{ FT-LB} \end{aligned}$$

3. From the temperature correction factor table, the correction factor (TCF) = .69.

4. Calculate adjusted application torque.

$$\begin{aligned} \text{ADJUSTED APPLICATION TORQUE} &= \frac{16.9}{.69} \\ &= 24.5 \text{ FT-LB} \end{aligned}$$

5. Select coupling.

AN MD-B40 WITH OPTIONAL SAMARIUM COBALT MAGNETS IS THE PROPER SELECTION.