

# VIKING® HEAVY DUTY PUMPS

SERIES 225 AND 4225

JACKETED BRACKET, STANDARD CONSTRUCTION

Section	142
Page	142.1
Issue	C

## FEATURES



SERIES 225 Pumps  
Cutaway View  
15-30-60-80-135 GPM Sizes  
(3-7-14-18-31 m³/hr)

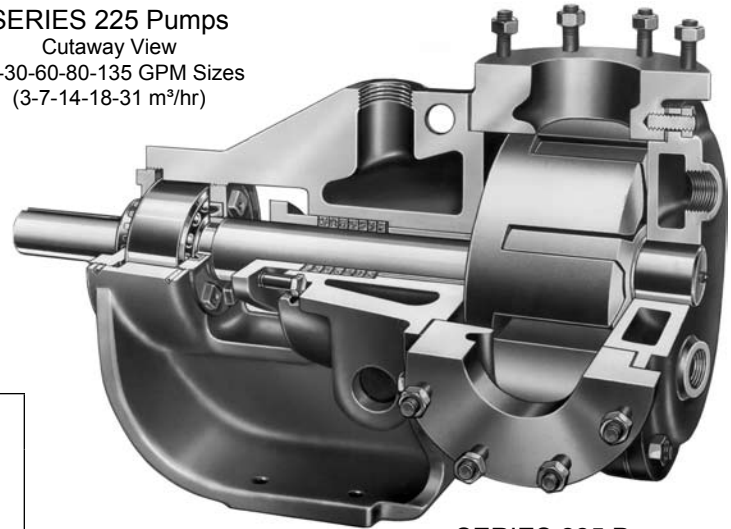

SERIES 225 Pumps  
Cutaway View  
140-200-300-420 GPM Sizes  
(32-45-68-95 m³/hr)

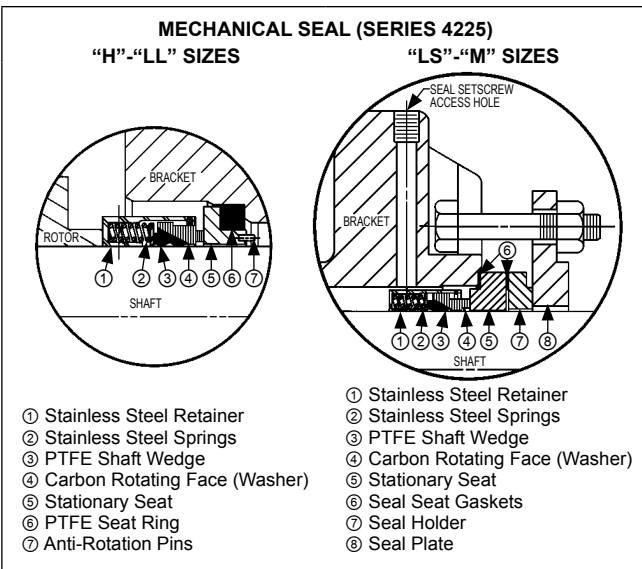

① Pressure Range	200 PSI (14 BAR) for 100 SSU (21 cSt) and above
	100 PSI (7 BAR) for below 100 SSU (21 cSt)
① Temperature Range	0°F. to +450°F. (-18°C. to +232°C.)
① Viscosity Range	28 SSU to 2,000,000 SSU (0.1 cP to 440,000 cSt)

**GPM 15-30-60-80-135-140-200-300-420**  
**(m³/hr 3-7-14-18-31-32-45-68-95)**  
② (Nominal Rating)

### Heavy-Duty Jacketed Bracket Pumps For Viscous Liquid Handling Problems

The jacketed bracket Series 225 and 4225 pumps use heavy-duty construction to tackle tough industrial jobs. The Viking positive displacement jacketed rotary pump provides an even flow when handling heavy, viscous liquids like asphalt, syrup, molasses, coal tar, soap solutions, etc. These liquids present temperature control problems, so jacketed areas at the front and back of the pumps allow preheating of the pump. Preheating is required with viscous liquids which cool down to ambient temperatures and become almost solid. Without preheating, this heavy mass can damage pumps, motors and total systems.

These pumps are available with either soft packing (Series 225) or with mechanical seals (Series 4225).

① Values shown represent minimums or maximums. Some special construction or consideration may be required before a cataloged pump can be applied to an application involving maximum pressure or minimum or maximum temperature and/or viscosity.

② Nominal capacities based on handling thin liquids at low pressures.

Metric conversions are based on US measurements and rounded to the nearest whole number.

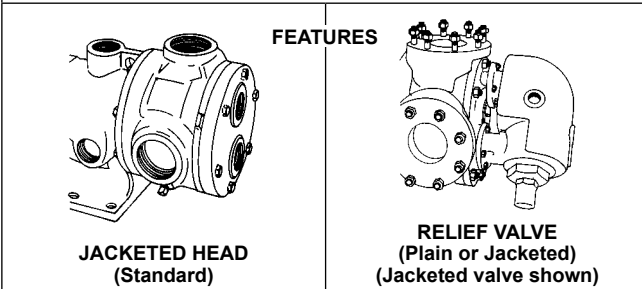

Jacketed head is standard with Jacketed Bracket Series 225 and 4225. For over pressure protection when using a jacketed head, a jacketed relief valve should be piped into the discharge line. Jacketed relief valves on head are available for pumps of 135 to 420 GPM (31 to 95 m³/hr); non-jacketed valves available for all sizes. (Note: combination of jacketed head and relief valve on head not available.)

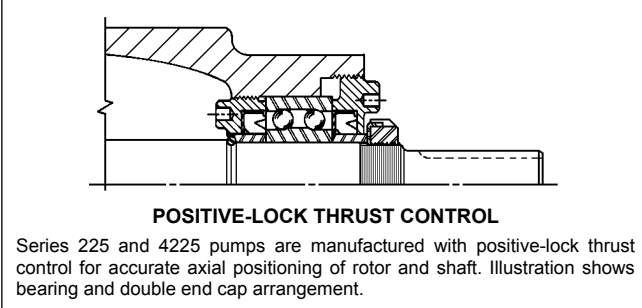

Section	142
Page	142.2
Issue	C

# VIKING® HEAVY DUTY PUMPS

## SERIES 225 AND 4225

### UNMOUNTED PUMPS

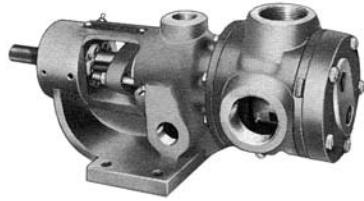

SERIES 225 and 4225 Pumps  
“H” and “HL” Sizes  
Shown with jacketed head plate



SERIES 225 and 4225 Pumps  
“K,” “KK” and “L” Sizes  
Shown with jacketed head plate

SERIES 225 and 4225 Pumps  
“LQ,” “LL” and “LS” Sizes  
Shown with jacketed head plate



SERIES 225 and 4225 Pumps  
“Q” and “M” Sizes  
Shown with jacketed relief valve

Dimensions for Unmounted Pumps—  
See Page 142.9.

Performance Data for Unmounted Pumps—  
See Pages 142.13 through 142.32 .

### CONSTRUCTION — SERIES 225 AND ① 4225 (“H” THROUGH “M” SIZES)

Pump Construction	Casing	Head	Bracket	Rotor	Idler	Rotor Shaft And Idler Pin	Shaft Sealing		Bushings			
									Packed		Mechanical Seal	
							Packed	Mech. Seal	Idler	Bracket	Idler	Bracket
Standard Construction	Iron	Iron	Iron	⑤ Iron	Iron	Steel	Standard	PTFE Seal	Bronze	Bronze	Carbon Graphite	Carbon Graphite
Steel Fitted	Iron	Iron	Iron	Steel	② Iron	Steel	Standard	PTFE Seal	Bronze	Bronze	Carbon Graphite	Carbon Graphite

NOTE: Relief valve cannot be used on pump with jacketed head plate or jacketed head.

### SPECIFICATIONS — SERIES 225 AND ① 4225 UNMOUNTED PUMPS

Model Number	Port Size	Nominal Pump Rating	Motor HP Required At Rated Speed Pumping 100 SSU Liquid		Maximum Hydrostatic Pressure	Steel Fitted Construction Recommended Above This Viscosity	⑤ Maximum Recommended Discharge Pressure When Handling 100 SSU Liquid At Nominal Rated Speeds	Maximum Temperature / Pressure of Fluids In Jackets				Approximate Shipping Weight With Jacketed Head		
								Steam (Sat.)		Heat Transfer Oil				
Packed	① ③ Mech. Seal	Inches	GPM (m³/hr)	RPM	50 PSI (3 BAR)	100 PSI (7 BAR)	PSIG (BAR)	SSU (cSt)	PSIG	Temp. °F. (°C)	Pressure PSIG (BAR)	Temp. °F. (°C)	Pressure PSIG (BAR)	Pounds (KG)
H225	H4225	1½	15 (3)	1800	1½	2	400 (28)	25,000 (5,500)	200	365 (185)	150 (10)	450 (232)	150 (10)	42 (19)
HL225	HL4225	1½	30 (7)	1800	2	3	400 (28)	7,500 (1,650)	200	365 (185)	150 (10)	450 (232)	150 (10)	45 (20)
K225	K4225	2	60 (14)	640	3	7½	400 (28)	25,000 (5,500)	200	365 (185)	150 (10)	450 (232)	150 (10)	120 (54)
KK225	KK4225	2	80 (18)	640	5	7½	400 (28)	25,000 (5,500)	200	365 (185)	150 (10)	450 (232)	150 (10)	125 (57)
L225	L4225	2	135 (31)	640	7½	15	400 (28)	25,000 (5,500)	200	365 (185)	150 (10)	450 (232)	150 (10)	175 (79)
LQ225	LQ4225	④ 2½	135 (31)	640	7½	15	400 (28)	25,000 (5,500)	200	365 (185)	150 (10)	450 (232)	150 (10)	190 (86)
LL225	LL4225	④ 3	140 (32)	520	7½	15	400 (28)	2,500 (550)	200	365 (185)	150 (10)	450 (232)	150 (10)	200 (91)
LS225	LS4225	④ 3	200 (45)	640	15	20	400 (28)	75,000 (16,500)	150	365 (185)	150 (10)	450 (232)	150 (10)	210 (95)
Q225	Q4225	④ 4	300 (68)	520	20	30	400 (28)	7,500 (1,650)	150	365 (185)	150 (10)	450 (232)	150 (10)	480 (218)
M225	M4225	④ 4	420 (95)	420	20	40	400 (28)	25,000 (5,500)	150	365 (185)	150 (10)	450 (232)	150 (10)	640 (291)

Note: Maximum recommended temperature for cataloged pump is 450°F. For higher temperatures consult factory.

① PTFE fitted mechanical seal used in Series 4225 pumps.

② “Q” size has steel idler.

③ For mechanical seal pumps on applications with viscosities greater than 25,000 SSU (5,500 cSt) anytime during operating cycle, check with factory.

④ Ports are suitable for use with 125# ANSI cast iron or 150# ANSI steel companion

flanges or flanged fittings. All others tapped for standard pipe.

⑤ “KK” and “LS” sizes have Ductile Iron rotor.

⑥ For maximum recommended discharge pressures when handling other viscosities and/or at other speeds, see performance curves. If suction pressure exceeds 50 PSIG (3 BAR), consult factory.

Metric conversions are based on US measurements and rounded to the nearest whole number.

# VIKING® HEAVY DUTY PUMPS

## SERIES 225 AND 4225

Section	142
Page	142.3
Issue	B

### VIKING HELICAL GEAR REDUCTION UNITS (“R” DRIVE)

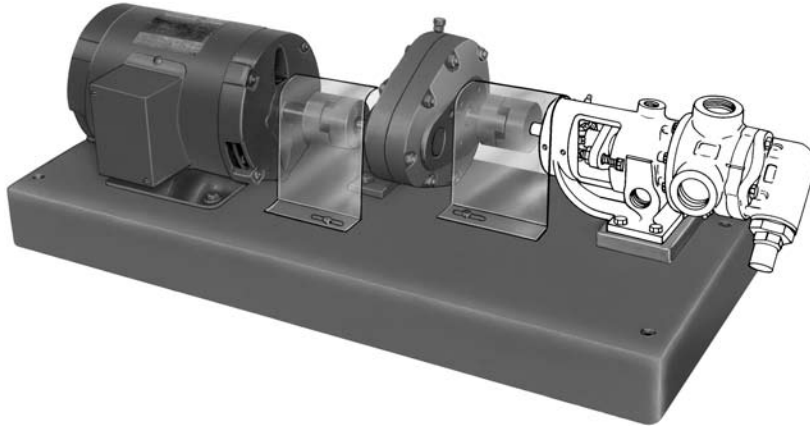

SERIES 225 and 4225 Pumps  
with “R” Drive “A” Reducer  
Shown with non-jacketed relief valve

SERIES 225 and 4225 Pumps  
with “R” Drive “B” Reducer  
Shown with jacketed head plate

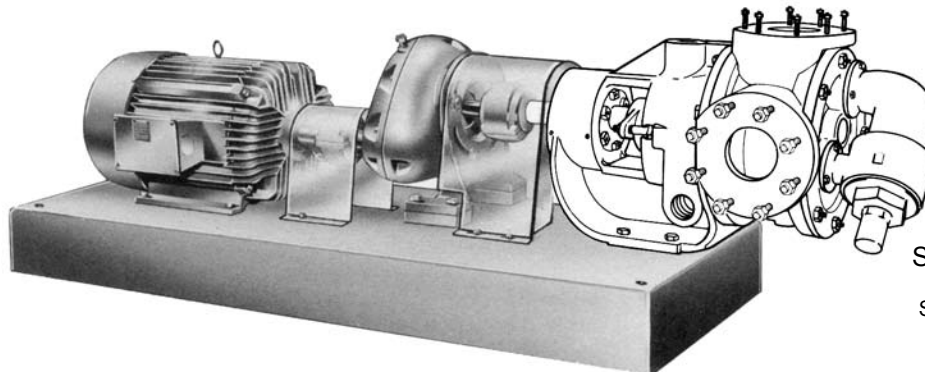
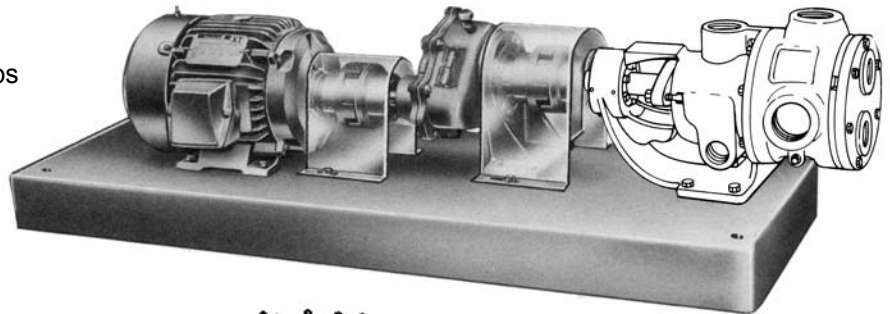

SERIES 225 and 4225 Pumps  
with “R” Drive “C” Reducer  
Shown with non-jacketed relief valve

Viking’s jacketed bracket pump Series 225 and 4225 are available with helical gear reducers that have been specifically developed for efficient operation with Viking heavy-duty pumps. These rugged, compact, exceptionally quiet gear reducers come in three sizes: the “small” A size, “medium” B size and “large” C size.

The “A” size reducer, available with four gear ratios (2.24, 2.76, 3.43, and 4.17 to 1), is ideally suited for use with the “H” and “HL” size pumps. This reducer is bracket mounted and requires couplings on both the input and output shafts. With the “A” size reducer and 1200 or 1800 RPM motors, the “H” and “HL” size pumps can be used to cover a capacity range from 2 to 12 GPM.

The medium size “B” helical gear reducer is available with eight gear ratios from 1.87:1 to 7.65:1. This size normally is used with pump sizes “K” through “LS”. Like

the “A” reducer, the “B” reducer is bracket mounted and requires couplings on both the input and the output shafts. With the “B” reducer, “K” through “LS” pumps driven by 1200 or 1800 RPM motors can be used to cover a capacity range from 12 to 210 GPM.

The large “C” size reducer also is available with seven gear ratios from 2.21:1 to 7.95:1. It is normally used with the “L” through “M” size pumps. Like the “A” and “B” reducers, the “C” reducer is bracket mounted and requires flexible couplings both for the input and output shafts. With the “C” reducer, “L” through “M” size pumps, driven by 1200 or 1800 RPM motors, can cover a capacity range from 30 to 420 GPM.

*Dimensions for “R” Drive Units— See Pages 142.10 and 142.11.*

*Performance Data for “R” Drive Units—See Pages 142.15 through 142.34.*

Section	142
Page	142.4
Issue	C

# VIKING® HEAVY DUTY PUMPS

## SERIES 225 AND 4225

### VIKING HELICAL GEAR REDUCER UNITS (“R” DRIVE)

#### SPECIFICATIONS — “R” DRIVE UNITS

Model Number	Port Size	Nominal Pump Rating		Motor HP Required At Rated Speed Pumping 100 SSU Liquid		Maximum Hydro-Static Pressure	Steel Fitted Construction Recommended Above This Viscosity	③ Maximum Recommended Discharge Pressure When Handling 100 SSU Liquid At Nominal Rated Speeds	Maximum Temperature / Pressure of Fluids in Jackets				Approximate Shipping Weight (Less Power) Pounds (KG)			
									Steam (Sat.)		Heat Transfer Oil					
Packed	① Mech. Seal	Inches	GPM (m³/hr)	RPM	50 PSI (3 BAR)	100 PSI (7 BAR)	PSIG (BAR)	SSU (cSt)	PSIG	Temp. °F. (°C.)	Pressure PSIG (BAR)	Temp. °F. (°C.)	Pressure PSIG (BAR)	“A” Reducer	“B” Reducer	“C” Reducer
H225R	H4225R	1½	15 (3)	1800	1½	2	400 (28)	25,000 (5,500)	200	365 (185)	150 (10)	450 (232)	150 (10)	129 (59)	....	....
HL225R	HL4225R	1½	30 (7)	1800	2	3	400 (28)	7,500 (1,650)	200	365 (185)	150 (10)	450 (232)	150 (10)	135 (61)	....	....
K225R	K4225R	2	60 (14)	640	3	7½	400 (28)	25,000 (5,500)	200	365 (185)	150 (10)	450 (232)	150 (10)	....	342 (155)	....
KK225R	KK4225R	2	80 (18)	640	5	7½	400 (28)	25,000 (5,500)	200	365 (185)	150 (10)	450 (232)	150 (10)	....	349 (158)	565 (257)
L225R	L4225R	2	135 (31)	640	7½	15	400 (28)	25,000 (5,500)	200	365 (185)	150 (10)	450 (232)	150 (10)	....	400 (182)	610 (277)
LQ225R	LQ4225R	④ 2½	135 (31)	640	7½	15	400 (28)	25,000 (5,500)	200	365 (185)	150 (10)	450 (232)	150 (10)	....	430 (195)	640 (291)
LL225R	LL4225R	④ 3	140 (32)	520	7½	15	400 (28)	2,500 (550)	200	365 (185)	150 (10)	450 (232)	150 (10)	....	460 (209)	670 (304)
LS225R	LS4225R	④ 3	200 (45)	640	15	20	400 (28)	75,000 (16,500)	150	365 (185)	150 (10)	450 (232)	150 (10)	....	510 (232)	720 (327)
Q225R	Q4225R	④ 4	300 (68)	520	20	30	400 (28)	7,500 (1,650)	150	365 (185)	150 (10)	450 (232)	150 (10)	....	....	1040 (472)
M225R	M4225R	④ 4	420 (95)	420	20	40	400 (28)	25,000 (5,500)	150	365 (185)	150 (10)	450 (232)	150 (10)	....	....	1180 (536)

① PTFE fitted mechanical seal used in Series 4225 pumps.

② For mechanical seal pumps on applications with viscosities greater than 25,000 SSU (5,500 cSt) anytime during operating cycle, check with factory.

③ For maximum recommended discharge pressures when handling other vis

cosities and/or at other speeds, see performance curves. If suction pressure exceeds 50 PSIG (3 BAR), consult factory.

④ Ports are suitable for use with 125# ANSI cast iron or 150# ANSI steel companion flanges or flanged fittings. All others tapped for standard pipe.

Metric conversions are based on US measurements and rounded to the nearest whole number.

#### OUTSTANDING FEATURES

- Mounts NEMA standard motors, 1200 or 1800 RPM. (5 HP, 1800 RPM maximum with “A” reducer; 15 HP, 1800 RPM maximum with “B” reducer, and 40 HP, 1800 RPM maximum with “C” reducer.)
- Complete reducers within a size may be interchanged on a Viking pump unit to obtain desired pump speeds and capacities. Thus the four gear ratios within the “A” size reducer may be interchanged within the size by selecting the proper pinion and gear of a common ratio. Similarly, all eight “B” reducers are interchangeable on each respective series of “B” reducer units. All seven “C” reducers are interchangeable on each respective series of “C” reducer units.
- Quiet operation. High hardness helical gears run in a bath of oil.
- Compact. Narrow and low to fit in small space and low overhead.
- Pump, motor or reducer can be removed without disturbing the other two components.
- Units with “A”, “B” and “C” reducers have standard flexible coupling with guard between power and reducer as well as between reducer and pump.
- Oil and weather tight for outdoor service.
- Ball bearings throughout.
- Reducers easily adjustable to different motor center heights.
- Self-supported. Not hung on pump or motor shafts. No radial load on pump or motor shafts.
- “A” reducers have ¾” dia., ⅜” key input and output shafts; “B” reducers have 1” dia., ¼” key input shaft and 1⅛” dia., ¼” key output shaft; “C” reducers have 1⅜” dia., ⅜” key input and output shafts.

# VIKING® HEAVY DUTY PUMPS

## SERIES 225 AND 4225

Section	142
Page	142.5
Issue	B

### VIKING HELICAL GEAR REDUCTION UNITS (“R” DRIVE)

**HELICAL REDUCER HORSEPOWER TABLE ② — “A” SIZE**

HIGH SPEED SHAFT INPUT RPM ①	GEAR REDUCER RATIOS “A” SIZE				
1750	780	640	520	420	LOW SPEED SHAFT RPM
	6.1	4.9	3.8	3.1	MAXIMUM REDUCER HP
1450	640	520	420	350	LOW SPEED SHAFT RPM
	5.2	4.2	3.2	2.7	MAXIMUM REDUCER HP
1150	520	420	350	280	LOW SPEED SHAFT RPM
	4.3	3.4	2.6	2.2	MAXIMUM REDUCER HP
950	420	350	280	230	LOW SPEED SHAFT RPM
	3.6	2.9	2.2	1.8	MAXIMUM REDUCER HP

① For input speeds higher than 1750 RPM, consult the factory.

② Horsepower ratings based on 8-10 hours operation per day, electric motor drive. See Catalog Section 610 for specific reducer sizing information.

**HELICAL REDUCER HORSEPOWER TABLE ② — “B” SIZE**

HIGH SPEED SHAFT INPUT RPM	GEAR REDUCER RATIOS “B” SIZE								
1750	950	780	640	520	420	350	280	230	LOW SPEED SHAFT RPM
	19.0	17.0	15.0	13.0	11.0	9.5	7.6	6.4	MAXIMUM REDUCER HP
1450	780	640	520	420	350	280	230	190	LOW SPEED SHAFT RPM
	17.3	15.5	13.4	11.6	9.9	8.5	6.4	5.4	MAXIMUM REDUCER HP
1150	640	520	420	350	280	230	190	155	LOW SPEED SHAFT RPM
	16.5	14.0	11.6	10.1	8.5	7.3	5.3	4.4	MAXIMUM REDUCER HP
950	520	420	350	280	230	190	155	125	LOW SPEED SHAFT RPM
	15.5	12.8	10.1	9.0	7.6	6.0	4.3	3.7	MAXIMUM REDUCER HP

① For input speeds higher than 1750 RPM, consult the factory.

② Horsepower ratings based on 8-10 hours operation per day, electric motor drive. See Catalog Section 610 for specific reducer sizing information.

**HELICAL REDUCER HORSEPOWER TABLE ② — “C” SIZE**

HIGH SPEED SHAFT INPUT RPM	GEAR REDUCER RATIOS “C” SIZE							
	① 2.21:1	2.80:1	3.31:1	4.21:1	5.08:1	6.24:1	7.95:1	
1750	780	640	520	420	350	280	220	LOW SPEED SHAFT RPM
	49.8	43.5	39.0	32.4	26.6	19.7	18.0	MAXIMUM REDUCER HP
1450	640	520	420	350	280	230	180	LOW SPEED SHAFT RPM
	45.3	36.6	32.8	27.2	22.3	16.7	15.2	MAXIMUM REDUCER HP
1150	520	420	350	280	230	190	145	LOW SPEED SHAFT RPM
	40.1	30.0	26.8	22.2	18.2	13.8	12.6	MAXIMUM REDUCER HP
950	420	350	280	230	190	155	120	LOW SPEED SHAFT RPM
	29.1	24.7	22.1	18.3	15.0	11.4	10.4	MAXIMUM REDUCER HP

① For input speeds higher than 1750 RPM, consult the factory.

② Horsepower ratings based on 8-10 hours operation per day, electric motor drive. See Catalog Section 610 for specific reducer sizing information.

Section	142
Page	142.6
Issue	C

# VIKING® HEAVY DUTY PUMPS

## SERIES 225 AND 4225

### GEAR REDUCER UNITS (“P” DRIVE)

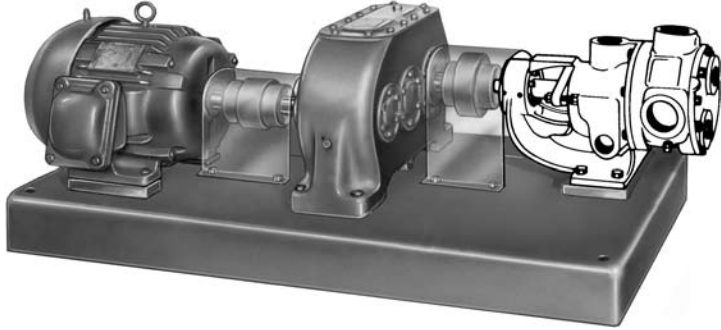

SERIES 225 and 4225 Pumps  
with “P” Drive  
“K” through “L” Sizes  
Shown with jacketed head plate

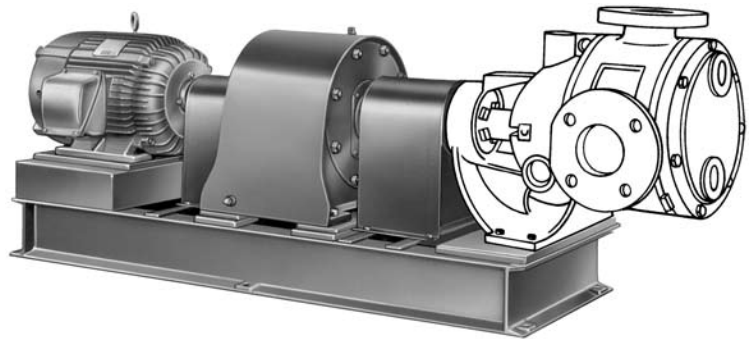

SERIES 225 and 4225 Pumps  
with “P” Drive  
“LQ” through “M” Sizes  
Shown with jacketed head plate

Viking’s Heavy-Duty Series 225 and 4225 packed and mechanical seal pumps in sizes from “K” through “M” (60 to 420 GPM) are available in the “P” drive arrangement.

These Heavy-Duty units are mounted on formed steel bases (“K” through “LS” sizes) and structural or formed steel bases (“Q” and “M” sizes) as illustrated above.

All mount separate heavy-duty reducers with flexible

couplings between pump, reducer and motor. Coupling guards as illustrated are standard construction. See below for specifications and motor horsepower range.

*Dimensions for “P” Drive Units — Consult Factory.*

*Performance Data for “P” Drive Units — See Pages 142.15 through 142.34.*

### SPECIFICATIONS — “P” DRIVE UNITS

Model Number		Port Size	Nominal Pump Rating		Motor HP Required At Rated Speed Pumping 100 SSU Liquid		Maximum Hydrostatic Pressure	Steel Fitted Construction Recommended Above This Viscosity	Maximum Recommended Discharge Pressure When Handling 100 SSU Liquid At Nominal Rated Speeds	Maximum Temperature / Pressure of Fluids In Jackets				Approximate Shipping Weight (Less Power)
										Steam (Sat.)		Heat Transfer Oil		
Packed	① ② Mech. Seal	Inches	GPM (m³/hr)	RPM	50 PSI (3 BAR)	100 PSI (7 BAR)	PSIG (BAR)	SSU (cSt)	(PSIG)	Temp. °F. (°C.)	Pressure PSIG (BAR)	Temp. °F. (°C.)	Pressure PSIG (BAR)	Pounds (KG)
K225P	K4225P	2	60 (14)	640	3	7½	400 (28)	25,000 (5,500)	200	365 (185)	150 (10)	450 (232)	150 (10)	363 (165)
KK225P	KK4225P	2	80 (18)	640	5	7½	400 (28)	25,000 (5,500)	200	365 (185)	150 (10)	450 (232)	150 (10)	368 (167)
L225P	L4225P	2	135 (31)	640	7½	15	400 (28)	25,000 (5,500)	200	365 (185)	150 (10)	450 (232)	150 (10)	413 (188)
LQ225P	LQ4225P	④ 2½	135 (31)	640	7½	15	400 (28)	25,000 (5,500)	200	365 (185)	150 (10)	450 (232)	150 (10)	443 (201)
LL225P	LL4225P	④ 3	140 (32)	520	7½	15	400 (28)	2,500 (550)	200	365 (185)	150 (10)	450 (232)	150 (10)	473 (215)
LS225P	LS4225P	④ 3	200 (45)	640	15	20	400 (28)	75,000 (16,500)	150	365 (185)	150 (10)	450 (232)	150 (10)	483 (219)
Q225P	Q4225P	④ 4	300 (65)	520	20	30	400 (28)	7,500 (1,650)	150	365 (185)	150 (10)	450 (232)	150 (10)	830 (377)
M225P	M4225P	④ 4	420 (95)	420	20	40	400 (28)	25,000 (5,500)	150	365 (185)	150 (10)	450 (232)	150 (10)	966 (439)

Note: Maximum recommended temperature for cataloged pump is 450°F. For higher temperatures consult factory.

- ① PTFE fitted mechanical seal used in Series 4225 pumps.
- ② For mechanical seal pumps on applications with viscosities greater than 25,000 SSU (5,500 cSt) anytime during operating cycle, check with factory.
- ③ For maximum recommended discharge pressures when handling other viscosities and/or at other speeds, see performance curves. If suction pressure exceeds 50

- PSIG (3 BAR), consult factory.
- ④ Ports are suitable for use with 125# ANSI cast iron or 150# ANSI steel companion flanges or flanged fittings. All others tapped for standard pipe.
- ⑤ Nominal rating based on handling thin liquids.

Metric conversions are based on US measurements and rounded to the nearest whole number.

# VIKING® HEAVY DUTY PUMPS

## SERIES 225 AND 4225

Section	142
Page	142.7
Issue	C

### DIRECT DRIVE UNITS (“D” DRIVE)

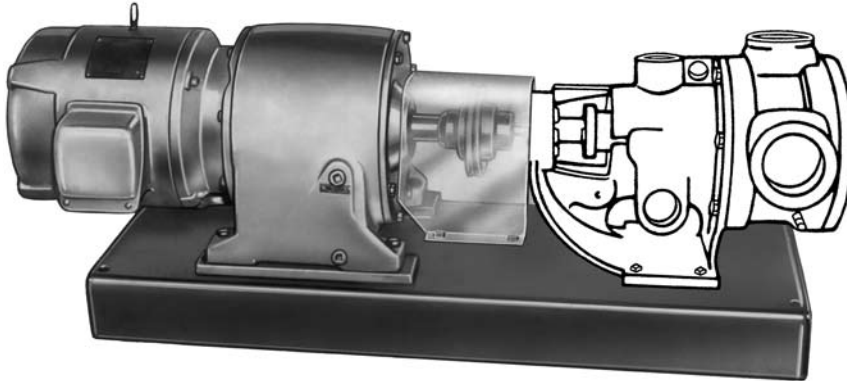

SERIES 225 and 4225 Pumps  
with “D” Drive  
“K” through “M” Sizes  
“K” size shown with non-jacketed head

SERIES 225 and 4225 Pumps  
with “D” Drive  
“H” and “HL” Sizes  
Shown with non-jacketed head

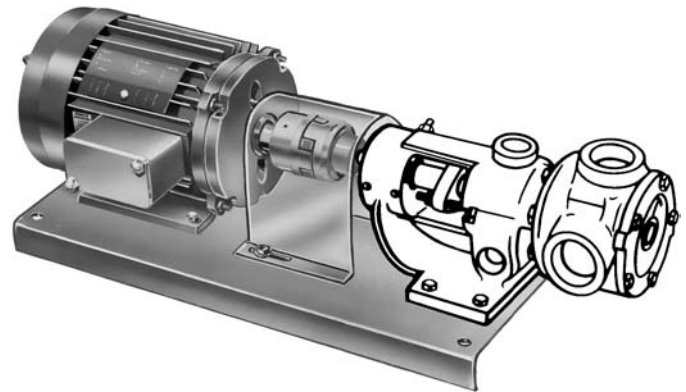

The Direct Drive “D” mounting is specifically designed for compactness and quietness of operation. In this type assembly the pump is mounted on one end of a rectangular formed steel base and connected to a gearhead motor by means of a flexible coupling with guard. “H” and “HL” sizes can be directly connected to 1800 RPM motors, as well as gearhead motors.

Dimensions for “D” Drive Units—See Pages 142.11 and 142.12.  
Performance Data for “D” Drive Units—See Pages 142.15 through 142.34.

### SPECIFICATIONS — “D” DRIVE UNITS

Model Number	Port Size	⑤ Nominal Pump Rating		Motor HP Required At Rated Speed Pumping 100 SSU Liquid		Maximum Hydrostatic Pressure	Steel Fitted Construction Recommended Above This Viscosity	③ Maximum Recommended Discharge Pressure When Handling 100 SSU Liquid At Nominal Rated Speeds	Maximum Temperature / Pressure of Fluids In Jackets				Approximate Shipping Weight (Less Power)	
									Steam (Sat.)		Heat Transfer Oil			
Packed	① ② Mech. Seal	Inches	GPM (m³/hr)	RPM	50 PSI (3 BAR)	100 PSI (7 BAR)	PSIG (BAR)	SSU (cSt)	(PSIG)	Temp. °F. (°C.)	Pressure PSIG (BAR)	Temp. °F. (°C.)	Pressure PSIG (BAR)	Pounds (KG)
H225D	H4225D	1½	15 (3)	1800	1½	2	400 (28)	25,000 (5,500)	200	365 (185)	150 (10)	450 (232)	150 (10)	109 (49)
HL225D	HL4225D	1½	30 (7)	1800	2	3	400 (28)	7,500 (1,650)	200	365 (185)	150 (10)	450 (232)	150 (10)	115 (52)
K225D	K4225D	2	60 (14)	640	3	7½	400 (28)	25,000 (5,500)	200	365 (185)	150 (10)	450 (232)	150 (10)	245 (111)
KK225D	KK4225D	2	80 (18)	640	5	7½	400 (28)	25,000 (5,500)	200	365 (185)	150 (10)	450 (232)	150 (10)	275 (125)
L225D	L4225D	2	135 (31)	640	7½	15	400 (28)	25,000 (5,500)	200	365 (185)	150 (10)	450 (232)	150 (10)	340 (154)
LQ225D	LQ4225D	④ 2½	135 (31)	640	7½	15	400 (28)	25,000 (5,500)	200	365 (185)	150 (10)	450 (232)	150 (10)	370 (168)
LL225D	LL4225D	④ 3	140 (32)	520	7½	15	400 (28)	2,500 (550)	200	365 (185)	150 (10)	450 (232)	150 (10)	425 (193)
LS225D	LS4225D	④ 3	200 (45)	640	15	20	400 (28)	75,000 (16,500)	150	365 (185)	150 (10)	450 (232)	150 (10)	435 (197)
Q225D	Q4225D	④ 4	300 (68)	520	20	30	400 (28)	7,500 (1,650)	150	365 (185)	150 (10)	450 (232)	150 (10)	860 (390)
M225D	M4225D	④ 4	420 (95)	420	20	40	400 (28)	25,000 (5,500)	150	365 (185)	150 (10)	450 (232)	150 (10)	1020 (463)

Note: Maximum recommended temperature for cataloged pump is 450°F. For higher temperatures consult factory.

- ① PTFE fitted mechanical seal used in Series 4225 pumps.
- ② For mechanical seal pumps on applications with viscosities greater than 25,000 SSU (5,500 cSt) anytime during operating cycle, check with factory.
- ③ For maximum recommended discharge pressures when handling other viscosities and/or at other speeds, see performance curves. If suction pressure exceeds 50

- PSIG (3 BAR), consult factory.
- ④ Ports are suitable for use with 125# ANSI cast iron or 150# ANSI steel companion flanges or flanged fittings. All others tapped for standard pipe.
- ⑤ Nominal rating based on handling thin liquids.

Metric conversions are based on US measurements and rounded to the nearest whole number.

Section	142
Page	142.8
Issue	C

# VIKING® HEAVY DUTY PUMPS

## SERIES 225 AND 4225

### V-BELT DRIVE UNITS (“V” DRIVE)

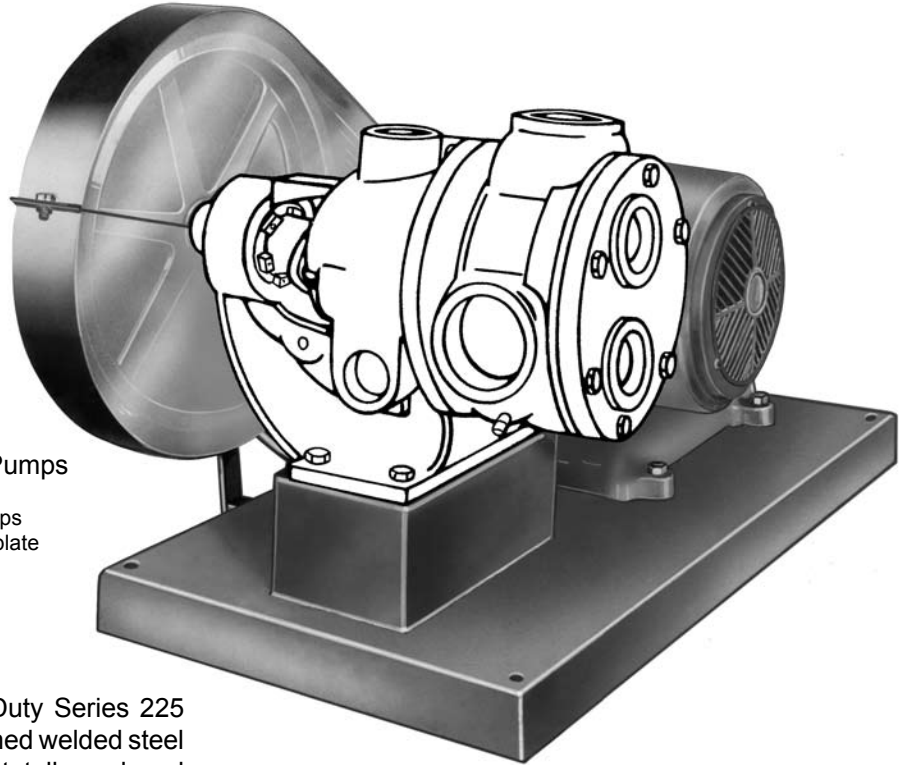

SERIES 225 and 4225 Pumps  
with “V” Drive  
“H” through “M” Size Pumps  
Shown with jacketed head plate

Viking's V-belt driven line of Heavy-Duty Series 225 and 4225 pumps are all mounted on formed welded steel bases. Pumps mount on pads to accept totally enclosed V-belt drive. All units in this series feature standard pump shaft extension with totally guarded V-driven pulley mounted on end of heavy-duty pump shaft.

Pumps furnished with jacketed head as standard.

Dimensions for “V” Drive Units—See Page 142.12.  
Performance Data for “V” Drive Units—See Pages 142.15 through 142.34.

### SPECIFICATIONS — “V” DRIVE UNITS

Model Number	Port Size	⑤ Nominal Pump Rating	Motor HP Required At Rated Speed Pumping 100 SSU Liquid		Maximum Hydrostatic Pressure	Steel Fitted Construction Recommended Above This Viscosity	③ Maximum Recommended Discharge Pressure When Handling 100 SSU Liquid At Nominal Rated Speeds	Maximum Temperature / Pressure of Fluids In Jackets				Approximate Shipping Weight (Less Power)		
			50 PSI (3 BAR)	100 PSI (7 BAR)				Steam (Sat.)		Heat Transfer Oil				
Packed	① ② Mech. Seal	Inches	GPM (m³/hr)	RPM	PSIG (BAR)	SSU (cSt)	(PSIG)	Temp. °F. (°C.)	Pressure PSIG (BAR)	Temp. °F. (°C.)	Pressure PSIG (BAR)	Pounds (KG)		
H225V	H4225V	1½	15 (3)	1800	1½	2	400 (28)	25,000 (5,500)	200	365 (185)	150 (10)	450 (232)	150 (10)	113 (51)
HL225V	HL4225V	1½	30 (7)	1800	2	3	400 (28)	7,500 (1,650)	200	365 (185)	150 (10)	450 (232)	150 (10)	119 (54)
K225V	K4225V	2	60 (14)	640	3	7½	400 (28)	25,000 (5,500)	200	365 (185)	150 (10)	450 (232)	150 (10)	270 (123)
KK225V	KK4225V	2	80 (18)	640	5	7½	400 (28)	25,000 (5,500)	200	365 (185)	150 (10)	450 (232)	150 (10)	280 (127)
L225V	L4225V	2	135 (31)	640	7½	15	400 (28)	25,000 (5,500)	200	365 (185)	150 (10)	450 (232)	150 (10)	325 (148)
LQ225V	LQ4225V	④ 2½	135 (31)	640	7½	15	400 (28)	25,000 (5,500)	200	365 (185)	150 (10)	450 (232)	150 (10)	355 (161)
LL225V	LL4225V	④ 3	140 (32)	520	7½	15	400 (28)	2,500 (550)	200	365 (185)	150 (10)	450 (232)	150 (10)	380 (173)
LS225V	LS4225V	④ 3	200 (45)	640	15	20	400 (28)	75,000 (16,500)	150	365 (185)	150 (10)	450 (232)	150 (10)	395 (179)
Q225V	Q4225V	④ 4	300 (68)	520	20	30	400 (28)	7,500 (1,650)	150	365 (185)	150 (10)	450 (232)	150 (10)	1026 (466)
M225V	M4225V	④ 4	420 (95)	420	20	40	400 (28)	25,000 (5,500)	150	365 (185)	150 (10)	450 (232)	150 (10)	1178 (535)

Note: Maximum recommended temperature for cataloged pump is 450°F. For higher temperatures consult factory.

- ① PTFE fitted mechanical seal used in Series 4225 pumps.
- ② For mechanical seal pumps on applications with viscosities greater than 25,000 SSU (5,500 cSt) anytime during operating cycle, check with factory.
- ③ For maximum recommended discharge pressures when handling other viscosities and/or at other speeds, see performance curves. If suction pressure exceeds 50

- PSIG (3 BAR), consult factory.
- ④ Ports are suitable for use with 125# ANSI cast iron or 150# ANSI steel companion flanges or flanged fittings. All others tapped for standard pipe.
- ⑤ Nominal rating based on handling thin liquids.

Metric conversions are based on US measurements and rounded to the nearest whole number.

# VIKING® HEAVY DUTY PUMPS

## SERIES 225 AND 4225

Section	142
Page	142.9
Issue	B

### DIMENSIONS

These dimensions are average and not for construction purposes. Certified prints on request.

For specifications, see page 142.2.

### DIMENSIONS SERIES 225 AND 4225 UNMOUNTED PUMPS

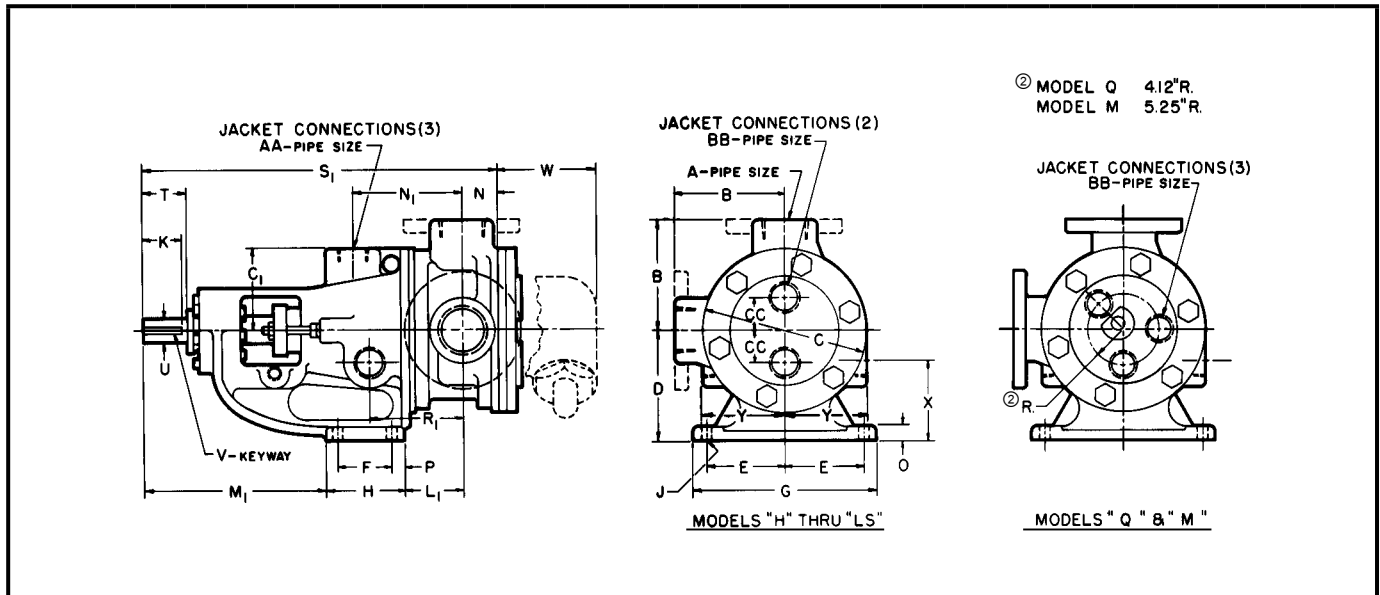

MODEL NO.		A	B	C	D	E	F	G	H	J	K	N	O	P	T	U	V	W	X	Y	C <sub>1</sub>	L <sub>1</sub>	M <sub>1</sub>	N <sub>1</sub>	R <sub>1</sub>	S <sub>1</sub>	AA	BB	CC	
PACKED	SEAL																													
H225 AND HL225	H4225 AND HL4225	1½	in	3.00	4.75	3.50	2.75	2.25	6.75	3.50	.47	1.50	1.19	.56	.62	1.62	.75	.19 x .09	2.88	1.80	1.83	2.38	3.38	5.19	4.00	4.00	13.25	¾	½	.94
			mm	76	121	89	70	57	171	89	12	38	30	14	16	41	19.05	4.76 x 2.38	73	46	46	60	86	132	102	102	337			24
K225 AND KK225	K4225 AND KK4225	2	in	5.12	8.00	5.50	4.00	2.75	9.25	4.00	.53	2.00	1.75	.62	.62	2.25	1.12	.25 x .12	5.12	3.38	2.75	4.00	3.00	9.38	5.75	5.75	18.12	1¼	1¼	1.75
			mm	130	203	140	102	70	235	102	13	51	44	16	16	57	28.58	6.35 x 3.18	130	86	70	102	76	238	146	146	460			44
L225	L4225	2	in	6.50	10.25	7.00	4.38	4.00	10.00	5.38	.53	2.00	1.75	.62	.62	2.25	1.12	.25 x .12	5.38	4.62	3.25	5.12	3.38	9.12	6.56	6.56	19.62	1¼	1	3.00
			mm	165	260	178	111	102	254	137	13	51	44	16	16	57	28.58	6.35 x 3.18	137	117	83	130	86	232	167	167	498			76
LQ225	LQ4225	⓪ 2½	in	7.19	10.25	7.00	4.38	4.00	10.00	5.38	.53	2.00	1.75	.62	.62	2.25	1.12	.25 x .12	5.38	4.62	3.25	5.12	3.38	9.12	6.56	6.56	19.62	1¼	1	3.00
			mm	183	260	178	111	102	254	137	13	51	44	16	16	57	28.58	6.35 x 3.18	137	117	83	130	86	232	167	167	498			76
LL225	LL4225	⓪ 3	in	7.19	10.25	7.00	4.38	4.00	10.00	5.38	.53	2.00	2.25	.62	.62	2.25	1.12	.25 x .12	5.38	4.62	3.25	5.12	3.38	9.12	6.56	6.56	20.12	1¼	1	3.00
			mm	183	260	178	111	102	254	137	13	51	57	16	16	57	28.58	6.35 x 3.18	137	117	83	130	86	232	167	167	511			76
LS225	LS4225	⓪ 3	in	7.19	10.25	7.00	4.38	4.00	10.00	5.38	.53	3.25	2.44	.62	.62	3.50	1.44	.38 x .19	5.19	4.40	3.30	5.12	4.75	9.12	7.40	7.00	21.69	1¼	1	3.00
			mm	183	260	178	111	102	254	137	13	83	62	16	16	89	36.51	9.53 x 4.76	132	112	84	130	121	232	188	178	551			76
Q225	Q4225	⓪ 4	in	8.25	14.00	8.75	4.12	4.00	10.00	6.00	.69	4.38	3.00	.75	1.00	4.50	1.94	.50 x .25	8.19	5.50	4.50	7.00	6.62	11.12	7.62	6.62	26.75	1½	1¼	—
			mm	210	356	222	105	102	254	152	18	111	76	19	25	114	49.21	12.70 x 6.35	208	140	114	178	168	282	194	168	679			—
M225	M4225	⓪ 4	in	9.50	17.25	10.00	5.00	6.00	12.00	8.50	.69	4.00	4.00	1.00	1.50	4.25	1.94	.50 x .25	8.50	5.50	6.00	8.62	7.75	8.12	8.30	6.90	28.38	1½	1½	—
			mm	241	438	254	127	152	305	216	18	102	102	25	38	108	49.21	12.70 x 6.35	216	140	152	219	197	206	211	175	721			—

⓪ Ports are suitable for use with 125# ANSI cast iron or 150# ANSI steel companion flanges or flanged fittings. All others tapped for standard N.P.T. pipe.

⓪ Model "Q" 4.12" R. Model "M" 5.25" R.

Section	142
Page	142.10
Issue	B

# VIKING® HEAVY DUTY PUMPS

## SERIES 225 AND 4225

### DIMENSIONS

These dimensions are average and not for construction purposes. Certified prints on request.

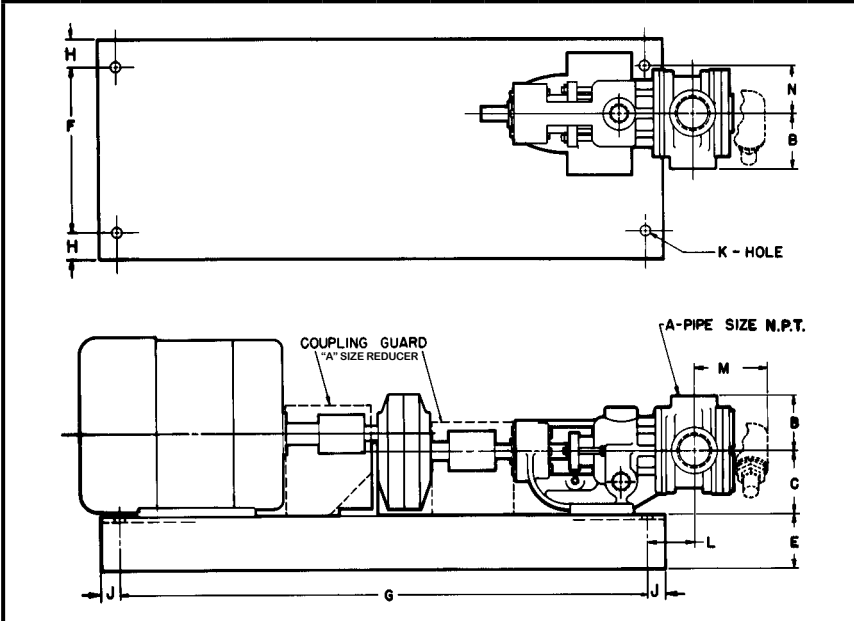

MODEL NUMBER		A	B	C	E	F	② G	H	J	K	L	M	N	
PACKED	SEAL													
H225R AND HL225R	H4225R AND HL4225R	1½	in	3.00	3.50	2.94	9.00	29.00	1.50	1.00	.56	2.62	4.06	2.62
			mm	76	89	75	229	737	38	25	14	67	103	67

For specifications, see pages 142.3 through 142.5.

### DIMENSIONS— SERIES 225 AND 4225 ("R" DRIVE) "H" AND "HL" SIZE PUMPS "A" SIZE REDUCER UNITS

- ① Base suitable for 56 through 184-T frame motors. (Base has closed ends.)
- ② For motor frame 213-T dimension "G" increases to 34.00". All other dimensions remain the same. (Base has open ends.)

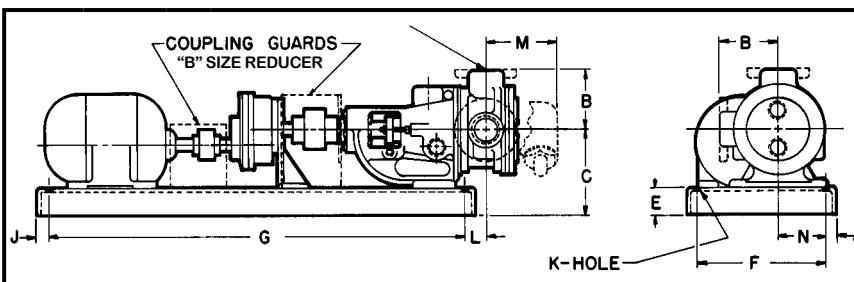

MODEL NUMBER		A	B	C	E	F	G	J	K	L	M	N	
PACKED	SEAL												
② K225R AND KK225R	② K4225R AND KK4225R	2	in	5.12	9.50	4.00	14.25	48.00	1.38	.62	2.00	6.88	4.25
			mm	130	241	102	362	1219	35	16	51	175	108
L225R	L4225R	2	in	6.50	11.00	4.00	14.25	48.00	1.38	.62	2.38	7.12	4.62
			mm	165	279	102	362	1219	35	16	60	181	117
LQ225R	LQ4225R	① 2½	in	7.19	11.00	4.00	14.25	48.00	1.38	.62	2.38	7.12	4.62
			mm	183	279	102	362	1219	35	16	60	181	117
LL225R	LL4225R	① 3	in	7.19	11.00	4.00	14.25	48.00	1.38	.62	2.38	7.62	4.62
			mm	183	279	102	362	1219	35	16	60	194	117
LS225R	LS4225R	① 3	in	7.19	11.00	4.00	14.25	48.00	1.38	.62	3.75	7.62	4.62
			mm	183	279	102	362	1219	35	16	95	194	117

For specifications, see pages 142.3 through 142.5.

### DIMENSIONS— SERIES 225 AND 4225 ("R" DRIVE) "K" THROUGH "LS" SIZE PUMPS "B" SIZE REDUCER UNITS

- ① Ports are suitable for use with 125# ANSI cast iron or 150# ANSI steel companion flanges or flanged fittings. All others tapped for standard pipe.
- ① With motor frames 184-T and smaller, these units are assembled on a shorter base with the following dimension changes: (F = 16", G = 39", L = 3", N = 5½"). Motor rails 1½" high are required with 56, 143-T and 145-T frame motors.
- NOTE: Motor frame larger than 256-T requires larger base. Consult factory. Units available to accept 10 HP, 1200 RPM maximum motor.
- NOTE: Motor rails 2" high are required on "L" through "LS" size units with 184-T or 4½" center height motors.

# VIKING® HEAVY DUTY PUMPS

## SERIES 225 AND 4225

Section	142
Page	142.11
Issue	B

### DIMENSIONS

These dimensions are average and not for construction purposes. Certified prints on request.

For specifications, see pages 142.3 through 142.5.

### DIMENSIONS — SERIES 225 AND 4225 ("R" DRIVE) "KK" THROUGH "M" SIZE PUMPS "C" SIZE REDUCER UNITS

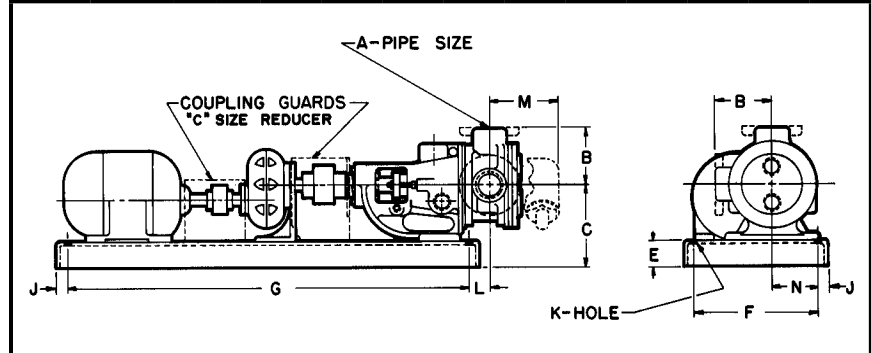

MODEL NUMBER		A	B	C	E	F	G	J	K	L	M	N
PACKED	SEAL											
KK225R	KK4225R	2	in 5.12	13.75	6.00	21.00	49.00	1.50	.69	3.00	6.88	6.06
			mm 130	349	152	533	1245	38	18	76	175	154
L225R	L4225R	2	in 6.50	13.75	6.00	19.75	59.50	1.50	.69	0	7.12	5.75
			mm 165	349	152	502	1511	38	18	0	181	146
LQ225R	LQ4225R	①	in 7.19	13.75	6.00	19.75	59.50	1.50	.69	0	7.12	5.75
		2½	mm 183	349	152	502	1511	38	18	0	181	146
LL225R	LL4225R	①	in 7.19	13.75	6.00	19.75	59.50	1.50	.69	0	7.62	5.75
		3	mm 183	349	152	502	1511	38	18	0	194	146
LS225R	LS4225R	①	in 7.19	13.75	6.00	19.75	59.50	1.50	.69	1.38	7.62	5.75
		3	mm 183	349	152	502	1511	38	18	35	194	146
Q225R	Q4225R	①	in 8.25	14.75	6.00	19.75	59.50	1.50	.69	2.88	11.19	5.75
		4	mm 210	375	152	502	1511	38	18	73	284	146
M225R	M4225R	①	in 9.50	16.00	6.00	19.75	59.50	1.50	.69	3.50	12.50	5.75
		4	mm 241	406	152	502	1511	38	18	89	318	146

① Ports are suitable for use with 125# ANSI cast iron or 150# ANSI steel companion flanges or flanged fittings. All others tapped for standard pipe.

For specifications, see page 142.7.

### DIMENSIONS — SERIES 225 AND 4225 ("D" DRIVE) "H" AND "HL" SIZE PUMPS DIRECT CONNECTED UNITS

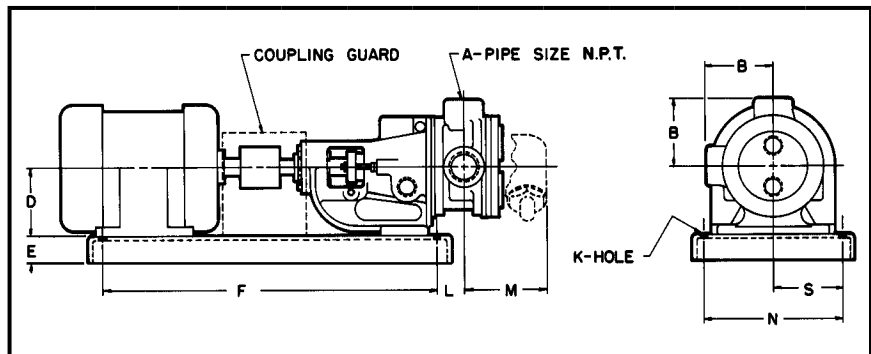

MODEL NUMBER		A	B	D	E	F	K	L	M	N	S
PACKED	SEAL										
H225D OR HL225D	H4225D OR HL4225D	1½	in 3.00	① 3.50	1.50	20.50	.50	1.75	4.06	8.50	4.25
			mm 76	89	38	521	13	44	103	216	108
		1½	in 3.00	② 4.50	2.94	25.00	.56	.56	4.06	9.00	4.50
			mm 76	114	75	635	14	14	103	229	114
1½	in 3.00	③ 5.25	2.94	25.00	.56	3.38	4.06	9.00	4.50		
	mm 76	133	75	635	14	86	103	229	114		

① For motor frames 56, 143-T and 145-T. (Base has open ends.)  
 ② For motor frames 182, 182-T, 184 and 184-T. (Base has closed ends.)  
 ③ For motor frames 213 through 215-T. (Base has closed ends.)

Section	142
Page	142.12
Issue	B

# VIKING® HEAVY DUTY PUMPS

## SERIES 225 AND 4225

### DIMENSIONS

These dimensions are average and not for construction purposes. Certified prints on request.

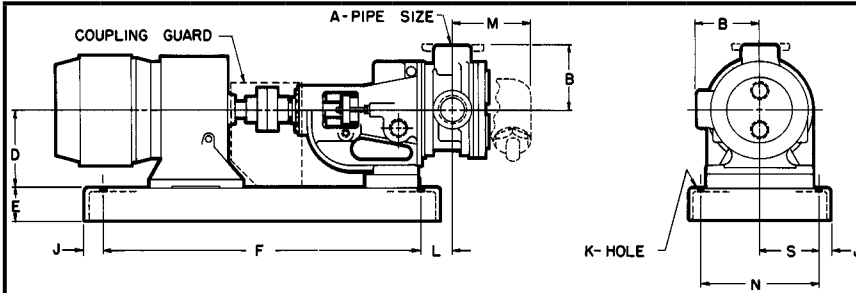

For specifications, see page 142.7.

### DIMENSIONS — SERIES 225 AND 4225 ("D" DRIVE) "K" THROUGH "M" SIZE PUMPS DIRECT CONNECTED UNITS

MODEL NUMBER		A		B	D <sup>②</sup>	E	F	J	K	L	M	N	S
PACKED	SEAL												
K225D AND KK225D	K4225D AND KK4225D	2	in	5.12		4.00	39.00	1.38	.62	3.00	6.88	16.00	8.00
			mm	130		102	991	35	16	76	175	406	203
L225D	L4225D	2	in	6.50		4.00	39.00	1.38	.62	3.38	7.12	16.00	8.00
			mm	165		102	991	35	16	86	181	406	203
LQ225D	LQ4225D	① 2½	in	7.19		4.00	39.00	1.38	.62	3.38	7.12	16.00	8.00
			mm	183		102	991	35	16	86	181	406	203
LL225D	LL4225D	① 3	in	7.19		4.00	39.00	1.38	.62	3.38	7.62	16.00	8.00
			mm	183		102	991	35	16	86	194	406	203
LS225D	LS4225D	① 3	in	7.19		4.00	39.00	1.38	.62	4.75	7.62	16.00	8.00
			mm	183		102	991	35	16	121	194	406	203
Q225D	Q4225D	① 4	in	8.25		6.00	59.50	1.50	.69	2.75	11.19	19.75	9.88
			mm	210		152	1511	38	18	70	284	502	251
M225D	M4225D	① 4	in	9.50		6.00	59.50	1.50	.69	3.88	12.50	19.75	9.88
			mm	241		152	1511	38	18	99	318	502	251

① Ports are suitable for use with 125# ANSI cast iron or 150# ANSI steel companion flanges or flanged fittings. All others tapped for standard pipe.

② Varies with gearmotor used.

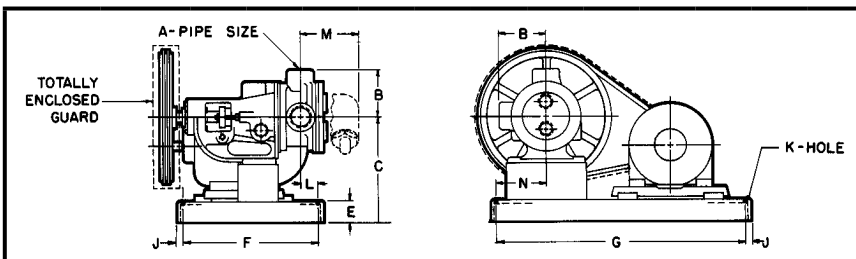

For specifications, see page 142.8.

### DIMENSIONS — SERIES 225 AND 4225 ("V" DRIVE) "H" THROUGH "M" SIZE PUMPS V-BELT DRIVE UNITS

MODEL NUMBER		A		B	C	E	F	G	J	K	L	M	N
PACKED	SEAL												
H225V <sup>①</sup> AND HL225V	H4225V AND HL4225V	1½	in	3.00	9.25	1.75	14.75	23.75	.75	.50	4.88	4.06	4.25
			mm	76	235	44	375	603	19	13	124	103	108
K225V <sup>③</sup> AND KK225V	K4225V AND KK4225V	2	in	5.12	13.81	3.25	17.00	28.75	1.00	.50	2.50	6.88	5.25
			mm	130	351	83	432	730	25	13	64	175	133
L225V <sup>③</sup>	L4225V	2	in	6.50	15.31	3.25	17.00	28.75	1.00	.50	2.25	7.12	5.25
			mm	165	389	83	432	730	25	13	57	181	133
LQ225V <sup>③</sup>	LQ4225V	① 2½	in	7.19	15.31	3.25	17.00	28.75	1.00	.50	2.25	7.12	5.25
			mm	183	389	83	432	730	25	13	57	181	133
LL225V <sup>③</sup>	LL4225V	① 3	in	7.19	15.31	3.25	17.00	28.75	1.00	.50	2.25	7.62	5.25
			mm	183	389	83	432	730	25	13	57	194	133
LS225V <sup>③</sup>	LS4225V	① 3	in	7.19	15.31	3.25	17.00	28.75	1.00	.50	1.06	7.62	5.25
			mm	183	389	83	432	730	25	13	27	194	133
Q225V	Q4225V	① 4	in	8.25	21.25	6.00	21.00	49.00	1.50	.81	2.75	11.19	8.50
			mm	210	540	152	533	1245	38	21	70	284	216
M225V	M4225V	① 4	in	9.50	22.50	6.00	21.00	49.00	1.50	.81	2.12	12.50	8.50
			mm	241	572	152	533	1245	38	21	54	318	216

① Ports are suitable for use with 125# ANSI cast iron or 150# ANSI steel companion flanges or flanged fittings. All others tapped for standard pipe.

② Base dimensions correct for all motors.

③ Base dimensions correct through frame 215-T motors and 19" OD sheaves. Larger motors and/or 25" OD sheaves require larger base.