

Viking In-Line Helical Gear Reducers

Section	615
Page	615.1
Issue	C

Gear Ratio Range: (varies by reducer size) From 2.63:1 to 38.0:1 (Varies by reducer size)

Output Speeds (with 1750 rpm input) 46 – 665 rpm

Reducer Horsepower Range: .5 HP (.37 kW) to 350 HP (261 kW)

Major Design Features

Features:

- Available in eleven different sizes and a variety of ratios, all double reduction
- Compact design
- Universal mounting
 - solid input shaft
 - hollow input shaft with NEMA C or IEC Flange Mount Option
- High efficiency
- Low noise levels
- Gears in hardened and case-hardened steel
- Input and output shafts in high-strength steel
- Sizes 11, 21, and 31 with unpainted aluminum housings
- Sizes 35 – 100 with painted cast iron housings
- Sizes 11 – 41 come factory filled with synthetic lubricant and are “lubed for life.”



Size 31 Solid Shaft, input end



Size 31 Solid Shaft, output end



Size 21 NEMA C, input end



Size 21 NEMA C, output end

Section	615
Page	615.2
Issue	C

Viking In-Line Helical Gear Reducers

Viking In-Line helical gear reducers are available in 11 sizes and offer many ratios within each size range. All sizes and ratios offer a choice of a solid high speed input shaft or a hollow input shaft combined with a choice of NEMA C or IEC flange adaptors.

Sizes 11, 21, & 31 have aluminum housings (and aluminum flanges if NEMA C or IEC). They are shipped unpainted. Sizes 35 –100 have cast iron housings and are painted.

Sizes 11, 21, 31, 35 & 41 are supplied with lifetime lubrication (synthetic gear lubricant suitable for ambient temperatures 32 to 122°F (0 to 50°C), and do not have oil filling or oil level plugs. Sizes 51 – 100 require filling with the proper lubricant before start-up. (See TSM 615, Table 1 and Table 2.)

Additional ratios in all sizes may be available beyond those shown in this catalog section. Please consult factory for additional information.

SELECTING THE CORRECT VIKING IN-LINE HELICAL GEAR REDUCER

1. Determine the actual horsepower requirements of the application from the pump performance curve or specifications from other equipment.
2. Determine the “equivalent horsepower” for the application by multiplying the actual horsepower to be transmitted by the appropriate service factor, which can be obtained from the Service Factor Table on page 3. This service factor takes into account length of service per day, the load classification (uniform, moderate shock, heavy shock), and the type of drive. A table of driven load classifications is included to help you determine the service factor to use.
3. Find the reducer from the horsepower tables on pages 4 thru 14 which most closely matches your speed requirements. Make sure the application’s equivalent horsepower (kW) for a given input speed and ratio is less than or equal to the maximum recommended horsepower (kW) shown in the chart on the “MAXIMUM REDUCER HORSEPOWER / kW” lines.

Example:

A Viking K124A requires a 7.3 HP driver at 390 rpm to deliver the desired output of 40 gpm at 200 psi on 7500 SSU fluid (from the pump curve), and is driven 24 hours per day. Using the Service Factor table, multiply the service factor (in this case 1.25) times the horsepower required (7.3 HP) for a reducer requirement of 9.13 HP.

Looking at the Specifications tables using a 1750 rpm motor, the desired 390 RPM output speed requires a gear ratio of about 4.5:1. Reviewing the Horsepower tables, we find that the Size 35 reducer with a 4.62:1 ratio (giving a 379 rpm output speed) and a 11.2 HP rating most closely meets the requirements.

Important Ordering Information:

When ordering a reducer with solid shaft input all that is required is the part number of the reducer as is provided in the pages that follow. i.e. 3-551-XXX-YYY-00.

When ordering a reducer with NEMA C-flange or IEC flange motor mount, you must specify the motor frame size in the last two digits of the part number. i.e: 3-551-XXX-YYY-56 for 56C frame, or 3-551-XXX-YYY-21 for 213TC-215TC frame motor, or 3-551-XXX-YYY-13 for IEC 132 frame motor. The available motor flange sizes are listed at the bottom of each reducer size specification table.

Special note: Use -10 as last two digits for IEC frames 100 and 112 as they are dimensionally interchangeable.

Viking In-Line Helical Gear Reducers

Section	615
Page	615.3
Issue	C

SERVICE FACTOR TABLE

POWER SOURCE	CLASSIFICATION OF DRIVEN LOAD*	INTERMITTENT UP TO 3 HOURS per DAY	8 – 10 HOURS per DAY	24 HOURS per DAY
Electric Motor, Steam Turbine, or Hydraulic Motor	Uniform	0.8	1.0	1.25
	Moderate Shock	1.0	1.25	1.5
	Heavy Shock	1.5	1.75	2.0
Multi-cylinder Internal Combustion Engine	Uniform	1.0	1.25	1.5
	Moderate Shock	1.25	1.5	1.75
	Heavy Shock	1.75	2.0	2.25

* Rotary Pump applications are classified as Uniform Loads.

DRIVEN LOAD CLASSIFICATIONS

(excerpted from AGMA Information Sheet 922-A96©1996)

Key: U = Uniform Load; M = Moderate Shock Load; H = Heavy Shock Load

APPLICATION	LOAD CLASSIFICATION	APPLICATION	LOAD CLASSIFICATION
Pumps, Rotary and Centrifugal	U	Fans, Cooling Tower	M
Pumps, Reciprocating	M	Feeders, Apron, Belt, Screw	U
Agitators	U	Feeders, Reciprocating	M
Blowers	U	Generators	U
Compressors, Centrifugal & Lobe	U	Hammer Mills	M
Compressors, Reciprocating	M	Machine Tools	M
Cranes and Hoists	M	Mills, Rotary	M
Crushers, Ore and Stone	H	Mixers, Concrete, Drum Type	M
Elevators	M	Printing Presses	U
Fans, Centrifugal, Forced Draft	U	Sewage Disposal Bar Screens	U

REDUCER WEIGHT

Reducer weights are shown on specification page for each reducer. The weights are approximate and are given in Lbs. (Kg). Basic frame sizes are shown but other frame sizes are included. For example, 145TC is actually for the 143TC and 145TC. Complete list is shown below.

145TC = 143TC and 145TC	71 IEC = 63 IEC and 71 IEC
184TC = 182TC and 184TC	90 IEC = 80 IEC and 90 IEC
215TC = 213TC and 215TC	
256TC = 254TC and 256TC	
286TC = 284TC and 286TC	

Section	615
Page	615.4
Issue	C

Viking In-Line Helical Gear Reducers

SPECIFICATIONS: SIZE 11

Output Speed / Maximum Horsepower (kW) at Given Input Speed						
	Viking Part No.	Ratio	1750 rpm	1450 rpm	1150 rpm	950 rpm
Solid Shaft Nema C flg. IEC flg.	3-551-110-028-00 3-551-11C-028-(frame size) 3-551-11E-028-(frame size)	2.77	632 / 3.4 (2.5)	523 / 3.0 (2.2)	415 / 2.5 (1.8)	343 / 1.9 (1.4)
Solid Shaft Nema C flg. IEC flg.	3-551-110-037-00 3-551-11C-037-(frame size) 3-551-11E-037-(frame size)	3.65	479 / 2.9 (2.1)	397 / 2.5 (1.8)	315 / 2.1 (1.6)	260 / 1.6 (1.2)
Solid Shaft Nema C flg. IEC flg.	3-551-110-049-00 3-551-11C-049-(frame size) 3-551-11E-049-(frame size)	4.87	359 / 2.5 (1.8)	298 / 2.2 (1.6)	236 / 1.8 (1.3)	195 / 1.4 (1.0)
Solid Shaft Nema C flg. IEC flg.	3-551-110-062-00 3-551-11C-062-(frame size) 3-551-11E-062-(frame size)	6.23	281 / 2.2 (1.6)	233 / 1.9 (1.4)	185 / 1.6 (1.2)	152 / 1.2 (.89)
Solid Shaft Nema C flg. IEC flg.	3-551-110-069-00 3-551-11C-069-(frame size) 3-551-11E-069-(frame size)	6.87	255 / 2.0 (1.5)	211 / 1.7 (1.2)	167 / 1.5 (1.1)	138 / 1.1 (.82)
Solid Shaft Nema C flg. IEC flg.	3-551-110-076-00 3-551-11C-076-(frame size) 3-551-11E-076-(frame size)	7.62	230 / 1.9 (1.4)	190 / 1.7 (1.2)	151 / 1.4 (1.0)	125 / 1.1 (.82)
Solid Shaft Nema C flg. IEC flg.	3-551-110-090-00 3-551-11C-090-(frame size) 3-551-11E-090-(frame size)	9.06	193 / 1.7 (1.3)	160 / 1.5 (1.1)	127 / 1.3 (.97)	105 / .95 (.71)
Solid Shaft Nema C flg. IEC flg.	3-551-110-101-00 3-551-11C-101-(frame size) 3-551-11E-101-(frame size)	10.1	174 / 1.6 (1.2)	144 / .4 (1.0)	114 / 1.2 (.90)	94 / .95 (.71)
Solid Shaft Nema C flg. IEC flg.	3-551-110-121-00 3-551-11C-121-(frame size) 3-551-11E-121-(frame size)	12.1	145 / 1.4 (1.0)	120 / 1.2 (.89)	95 / 1.0 (.74)	78 / .79 (.59)
Solid Shaft Nema C flg. IEC flg.	3-551-110-134-00 3-551-11C-134-(frame size) 3-551-11E-134-(frame size)	13.4	131 / 1.4 (1.0)	108 / 1.2 (.89)	86 / .99 (.74)	71 / .74 (.55)
Solid Shaft Nema C flg. IEC flg.	3-551-110-155-00 3-551-11C-155-(frame size) 3-551-11E-155-(frame size)	15.5	113 / 1.2 (.89)	93 / 1.1 (.82)	74 / .90 (.67)	61 / .68 (.50)
Solid Shaft Nema C flg. IEC flg.	3-551-110-172-00 3-551-11C-172-(frame size) 3-551-11E-172-(frame size)	17.2	102 / 1.1 (.82)	84 / .99 (.74)	67 / .83 (.62)	55 / .62 (.45)
Solid Shaft Nema C flg. IEC flg.	3-551-110-186-00 3-551-11C-186-(frame size) 3-551-11E-186-(frame size)	18.6	94 / 1.1 (.82)	78 / .95 (.71)	62 / .80 (.60)	51 / .60 (.44)
Solid Shaft Nema C flg. IEC flg.	3-551-110-206-00 3-551-11C-206-(frame size) 3-551-11E-206-(frame size)	20.6	85 / 1.0 (.75)	70 / .87 (.65)	56 / .70 (.52)	46 / .53 (.39)
Solid Shaft Nema C flg. IEC flg.	3-551-110-229-00 3-551-11C-229-(frame size) 3-551-11E-229-(frame size)	22.9	76 / .96 (.75)	63 / .83 (.62)	50 / .70 (.52)	41 / .53 (.39)

Size 11 Approx. weights Pre-filled with oil	Weights – Lbs. (Kg)			
	Solid Shaft	56C & 71 IEC	145TC & 90 IEC	184TC & 112 IEC
	10 (4.8)	13 (6)	15 (7)	24 (11)

Viking In-Line Helical Gear Reducers

Section	615
Page	615.5
Issue	C

SPECIFICATIONS: SIZE 21

Output Speed / Maximum Horsepower (kW) at Given Input Speed						
Viking Part No.		Ratio	1750 rpm	1450 rpm	1150 rpm	950 rpm
Solid Shaft	3-551-210-027-00	2.72	643 / 7.7 (5.7)	533 / 6.7 (5.0)	423 / 5.7 (4.2)	349 / 4.3 (3.2)
Nema C flg.	3-551-21C-027-(frame size)					
IEC flg.	3-551-21E-027-(frame size)					
Solid Shaft	3-551-210-037-00	3.71	472 / 6.3 (4.7)	391 / 5.5 (4.1)	310 / 4.6 (3.4)	256 / 3.5 (2.6)
Nema C flg.	3-551-21C-037-(frame size)					
IEC flg.	3-551-21E-037-(frame size)					
Solid Shaft	3-551-210-048-00	4.77	367 / 5.4 (4.0)	304 / 4.5 (3.3)	241 / 3.6 (2.7)	199 / 2.7 (2.0)
Nema C flg.	3-551-21C-048-(frame size)					
IEC flg.	3-551-21E-048-(frame size)					
Solid Shaft	3-551-210-061-00	6.09	287 / 4.5 (3.4)	238 / 3.7 (2.7)	189 / 2.9 (2.1)	156 / 2.2 (1.6)
Nema C flg.	3-551-21C-061-(frame size)					
IEC flg.	3-551-21E-061-(frame size)					
Solid Shaft	3-551-210-064-00	6.38	274 / 5.1 (3.8)	227 / 4.4 (3.3)	180 / 3.7 (2.7)	149 / 2.8 (2.1)
Nema C flg.	3-551-21C-064-(frame size)					
IEC flg.	3-551-21E-064-(frame size)					
Solid Shaft	3-551-210-071-00	7.08	247 / 4.7 (3.5)	205 / 4.1 (3.0)	162 / 3.4 (2.5)	134 / 2.6 (1.9)
Nema C flg.	3-551-21C-071-(frame size)					
IEC flg.	3-551-21E-071-(frame size)					
Solid Shaft	3-551-210-087-00	8.68	202 / 4.2 (3.1)	167 / 3.6 (2.7)	132 / 3.1 (2.3)	109 / 2.3 (1.7)
Nema C flg.	3-551-21C-087-(frame size)					
IEC flg.	3-551-21E-087-(frame size)					
Solid Shaft	3-551-210-097-00	9.65	181 / 3.9 (2.9)	150 / 3.3 (2.4)	119 / 2.8 (2.1)	98 / 2.1 (1.5)
Nema C flg.	3-551-21C-097-(frame size)					
IEC flg.	3-551-21E-097-(frame size)					
Solid Shaft	3-551-210-112-00	11.2	157 / 3.6 (2.7)	130 / 3.1 (2.3)	103 / 2.6 (1.9)	85 / 2.0 (1.5)
Nema C flg.	3-551-21C-112-(frame size)					
IEC flg.	3-551-21E-112-(frame size)					
Solid Shaft	3-551-210-124-00	12.4	141 / 3.3 (2.5)	117 / 2.9 (2.1)	93 / 2.4 (1.8)	77 / 1.8 (1.3)
Nema C flg.	3-551-21C-124-(frame size)					
IEC flg.	3-551-21E-124-(frame size)					
Solid Shaft	3-551-210-143-00	14.3	122 / 3.1 (2.3)	101 / 2.6 (1.9)	80 / 2.2 (1.6)	66 / 1.7 (1.2)
Nema C flg.	3-551-21C-143-(frame size)					
IEC flg.	3-551-21E-143-(frame size)					
Solid Shaft	3-551-210-158-00	15.8	111 / 2.9 (2.1)	92 / 2.5 (1.8)	73 / 2.1 (1.5)	60 / 1.5 (1.1)
Nema C flg.	3-551-21C-158-(frame size)					
IEC flg.	3-551-21E-158-(frame size)					
Solid Shaft	3-551-210-180-00	18.0	97 / 2.7 (2.0)	81 / 2.2 (1.6)	64 / 1.8 (1.3)	53 / 1.4 (1.0)
Nema C flg.	3-551-21C-180-(frame size)					
IEC flg.	3-551-21E-180-(frame size)					
Solid Shaft	3-551-210-200-00	20.0	88 / 2.5 (1.8)	73 / 2.0 (1.5)	57 / 1.6 (1.2)	47 / 1.2 (.89)
Nema C flg.	3-551-21C-200-(frame size)					
IEC flg.	3-551-21E-200-(frame size)					
Solid Shaft	3-551-210-219-00	21.9	80 / 2.4 (1.8)	66 / 1.9 (1.4)	52 / 1.5 (1.1)	43 / 1.1 (.82)
Nema C flg.	3-551-21C-219-(frame size)					
IEC flg.	3-551-21E-219-(frame size)					

Size 21 Approx. weights Pre-filled with oil	Weights – Lbs. (Kg)			
	Solid Shaft	56C & 71 IEC	145TC & 90 IEC	184TC & 112 IEC
	16 (7.2)	18 (8)	20 (9)	29 (13)

Section	615
Page	615.6
Issue	C

Viking In-Line Helical Gear Reducers

SPECIFICATIONS: SIZE 31

Output Speed / Maximum Horsepower (kW) at Given Input Speed						
	Viking Part No.	Ratio	1750 rpm	1450 rpm	1150 rpm	950 rpm
Solid Shaft Nema C flg. IEC flg.	3-551-310-029-00 3-551-31C-029-(frame size) 3-551-31E-029-(frame size)	2.88	608 / 11.6 (8.6)	503 / 10.0 (7.4)	399 / 8.4 (6.2)	330 / 6.3 (4.7)
Solid Shaft Nema C flg. IEC flg.	3-551-310-037-00 3-551-31C-037-(frame size) 3-551-31E-037-(frame size)	3.74	468 / 10.5 (7.8)	388 / 8.7 (6.5)	307 / 6.8 (5.0)	254 / 5.1 (3.8)
Solid Shaft Nema C flg. IEC flg.	3-551-310-050-00 3-551-31C-050-(frame size) 3-551-31E-050-(frame size)	4.95	354 / 8.0 (5.9)	293 / 6.6 (4.9)	232 / 5.3 (3.9)	192 / 3.9 (2.9)
Solid Shaft Nema C flg. IEC flg.	3-551-310-063-00 3-551-31C-063-(frame size) 3-551-31E-063-(frame size)	6.26	280 / 6.4 (4.7)	232 / 5.5 (4.1)	184 / 4.6 (3.4)	152 / 3.5 (2.6)
Solid Shaft Nema C flg. IEC flg.	3-551-310-065-00 3-551-31C-065-(frame size) 3-551-31E-065-(frame size)	6.45	271 / 7.8 (5.8)	225 / 6.7 (5.0)	178 / 5.6 (4.1)	147 / 4.2 (3.1)
Solid Shaft Nema C flg. IEC flg.	3-551-310-072-00 3-551-31C-072-(frame size) 3-551-31E-072-(frame size)	7.16	244 / 7.2 (5.4)	202 / 6.2 (4.6)	161 / 5.3 (3.9)	133 / 4.0 (3.0)
Solid Shaft Nema C flg. IEC flg.	3-551-310-084-00 3-551-31C-084-(frame size) 3-551-31E-084-(frame size)	8.37	209 / 6.6 (4.9)	173 / 5.7 (4.2)	137 / 4.8 (3.6)	114 / 3.6 (2.7)
Solid Shaft Nema C flg. IEC flg.	3-551-310-093-00 3-551-31C-093-(frame size) 3-551-31E-093-(frame size)	9.30	188 / 6.1 (4.5)	156 / 5.3 (3.9)	124 / 4.5 (3.3)	102 / 3.4 (2.5)
Solid Shaft Nema C flg. IEC flg.	3-551-310-111-00 3-551-31C-111-(frame size) 3-551-31E-111-(frame size)	11.1	158 / 5.6 (4.2)	131 / 4.8 (3.6)	104 / 4.1 (3.0)	86 / 3.1 (2.3)
Solid Shaft Nema C flg. IEC flg.	3-551-310-123-00 3-551-31C-123-(frame size) 3-551-31E-123-(frame size)	12.3	142 / 5.2 (3.8)	118 / 4.5 (3.3)	93 / 3.8 (2.8)	77 / 2.8 (2.0)
Solid Shaft Nema C flg. IEC flg.	3-551-310-140-00 3-551-31C-140-(frame size) 3-551-31E-140-(frame size)	14.0	125 / 4.8 (3.6)	104 / 4.1 (3.0)	82 / 3.5 (2.6)	68 / 2.6 (1.9)
Solid Shaft Nema C flg. IEC flg.	3-551-310-156-00 3-551-31C-156-(frame size) 3-551-31E-156-(frame size)	15.6	112 / 4.5 (3.3)	93 / 3.8 (2.8)	74 / 3.1 (2.3)	61 / 2.3 (1.7)
Solid Shaft Nema C flg. IEC flg.	3-551-310-181-00 3-551-31C-181-(frame size) 3-551-31E-181-(frame size)	18.1	97 / 4.1 (3.0)	80 / 3.4 (2.5)	64 / 2.7 (2.0)	52 / 2.0 (1.5)
Solid Shaft Nema C flg. IEC flg.	3-551-310-201-00 3-551-31C-201-(frame size) 3-551-31E-201-(frame size)	20.1	87 / 3.8 (2.8)	72 / 3.1 (2.3)	87 / 2.4 (1.8)	87 / 1.8 (1.3)
Solid Shaft Nema C flg. IEC flg.	3-551-310-226-00 3-551-31C-226-(frame size) 3-551-31E-226-(frame size)	22.6	77 / 3.4 (2.5)	64 / 2.8 (2.1)	57 / 2.2 (1.6)	47 / 1.6 (1.2)

Size 31 Approx. weights Pre-filled with oil	Weights – Lbs. (Kg)		
	Solid Shaft	145TC & 90 IEC	184TC & 112 IEC
	24 (11)	24 (11)	33 (15)

Viking In-Line Helical Gear Reducers

Section	615
Page	615.7
Issue	C

SPECIFICATIONS: SIZE 35

Output Speed / Maximum Horsepower (kW) at Given Input Speed						
Viking Part No.		Ratio	1750 rpm	1450 rpm	1150 rpm	950 rpm
Solid Shaft	3-551-350-027-00	2.69	651 / 16.2 (12.1)	539 / 13.8 (10.3)	427 / 11.4 (8.5)	353 / 8.6 (6.4)
Nema C flg.	3-551-35C-027-(frame size)					
IEC flg.	3-551-35E-027-(frame size)					
Solid Shaft	3-551-350-035-00	3.49	501 / 13.7 (10.2)	415 / 11.5 (8.5)	330 / 9.3 (6.9)	272 / 7.0 (5.2)
Nema C flg.	3-551-35C-035-(frame size)					
IEC flg.	3-551-35E-035(frame size)					
Solid Shaft	3-551-350-046-00	4.62	379 / 11.2 (8.4)	314 / 9.2 (6.8)	249 / 7.1 (5.3)	206 / 5.3 (3.9)
Nema C flg.	3-551-35C-046-(frame size)					
IEC flg.	3-551-35E-046-(frame size)					
Solid Shaft	3-551-350-058-00	5.85	299 / 8.9 (6.6)	248 / 7.3 (5.4)	197 / 5.6 (4.1)	162 / 4.2 (3.1)
Nema C flg.	3-551-35C-058-(frame size)					
IEC flg.	3-551-35E-058-(frame size)					
Solid Shaft	3-551-350-061-00	6.10	287 / 14.6 (10.9)	238 / 12.4 (9.28)	188 / 10.1 (7.5)	156 / 7.6 (5.6)
Nema C flg.	3-551-35C-061-(frame size)					
IEC flg.	3-551-35E-061-(frame size)					
Solid Shaft	3-551-350-068-00	6.78	258 / 13.5 (10.0)	214 / 11.3 (8.4)	170 / 9.1 (6.7)	140 / 6.8 (5.0)
Nema C flg.	3-551-35C-068-(frame size)					
IEC flg.	3-551-35E-068-(frame size)					
Solid Shaft	3-551-350-079-00	7.91	221 / 12.4 (9.3)	183 / 10.1 (7.5)	145 / 7.8 (5.8)	120 / 5.9 (4.4)
Nema C flg.	3-551-35C-079-(frame size)					
IEC flg.	3-551-35E-079-(frame size)					
Solid Shaft	3-551-350-088-00	8.80	199 / 11.2 (8.3)	165 / 9.1 (6.7)	131 / 7.0 (5.2)	108 / 5.3 (3.96)
Nema C flg.	3-551-35C-088-(frame size)					
IEC flg.	3-551-35E-088-(frame size)					
Solid Shaft	3-551-350-105-00	10.5	167 / 9.4 (7.0)	138 / 7.6 (5.6)	110 / 5.9 (4.4)	91 / 4.3 (3.2)
Nema C flg.	3-551-35C-105-(frame size)					
IEC flg.	3-551-35E-105-(frame size)					
Solid Shaft	3-551-350-117-00	11.7	150 / 8.4 (6.3)	124 / 6.8 (5.0)	98 / 5.3 (3.9)	81 / 4.0 (3.0)
Nema C flg.	3-551-35C-117-(frame size)					
IEC flg.	3-551-35E-117-(frame size)					
Solid Shaft	3-551-350-133-00	13.3	132 / 7.4 (5.5)	109 / 6.0 (4.4)	86 / 4.6 (3.4)	71 / 3.5 (2.6)
Nema C flg.	3-551-35C-133-(frame size)					
IEC flg.	3-551-35E-133-(frame size)					
Solid Shaft	3-551-350-148-00	14.8	118 / 6.6 (4.9)	98 / 5.4 (4.0)	78 / 4.2 (3.1)	64 / 3.1 (2.3)
Nema C flg.	3-551-35C-148-(frame size)					
IEC flg.	3-551-35E-148-(frame size)					
Solid Shaft	3-551-350-171-00	17.1	102 / 5.7 (4.2)	85 / 4.7 (3.5)	67 / 3.6 (2.6)	56 / 2.7 (2.0)
Nema C flg.	3-551-35C-171-(frame size)					
IEC flg.	3-551-35E-171-(frame size)					
Solid Shaft	3-551-350-190-00	19.0	92 / 5.2 (3.8)	76 / 4.2 (3.1)	60 / 3.2 (2.3)	50 / 2.4 (1.8)
Nema C flg.	3-551-35C-190-(frame size)					
IEC flg.	3-551-35E-190-(frame size)					

Size 35 Approx. weights Pre-filled with oil	Weights – Lbs. (Kg)			
	Solid Shaft	145TC & 90 IEC	184TC & 112 IEC	215TC & 132 IEC
	56 (26)	46 (21)	55 (25)	60(27)

Section	615
Page	615.8
Issue	C

Viking In-Line Helical Gear Reducers

SPECIFICATIONS: SIZE 41

Output Speed / Maximum Horsepower (kW) at Given Input Speed						
Viking Part No.	Ratio	1750 rpm	1450 rpm	1150 rpm	950 rpm	
Solid Shaft Nema C flg. IEC flg.	3-551-410-027-00 3-551-41C-027-(frame size) 3-551-41E-027-(frame size)	2.69	651 / 23.5 (17.5)	539 / 19.1 (14.2)	427 / 14.8 (11.0)	353 / 11.1 (8.2)
Solid Shaft Nema C flg. IEC flg.	3-551-410-036-00 3-551-41C-036-(frame size) 3-551-41E-036-(frame size)	3.61	485 / 18.3 (13.6)	402 / 14.9 (11.1)	319 / 11.5 (8.5)	263 / 8.6 (6.4)
Solid Shaft Nema C flg. IEC flg.	3-551-410-047-00 3-551-41C-047-(frame size) 3-551-41E-047-(frame size)	4.66	375 / 14.3 (10.6)	311 / 11.6 (8.6)	247 / 9.0 (6.7)	204 / 6.9 (5.15)
Solid Shaft Nema C flg. IEC flg.	3-551-410-060-00 3-551-41C-060-(frame size) 3-551-41E-060-(frame size)	5.95	294 / 11.2 (8.3)	244 / 9.1 (6.7)	193 / 7.0 (5.2)	160 / 5.3 (3.9)
Solid Shaft Nema C flg. IEC flg.	3-551-410-064-00 3-551-41C-064-(frame size) 3-551-41E-064-(frame size)	6.36	275 / 13.9 (10.3)	228 / 12.0 (8.9)	181 / 10.0 (7.4)	149 / 7.6 (5.6)
Solid Shaft Nema C flg. IEC flg.	3-551-410-071-00 3-551-41C-071-(frame size) 3-551-41E-071-(frame size)	7.07	247 / 12.9 (9.6)	205 / 11.2 (8.3)	163 / 9.5 (7.0)	134 / 7.1 (5.3)
Solid Shaft Nema C flg. IEC flg.	3-551-410-086-00 3-551-41C-086-(frame size) 3-551-41E-086-(frame size)	8.64	202 / 11.6 (8.6)	168 / 10.0 (7.4)	133 / 8.4 (6.2)	110 / 6.3 (4.7)
Solid Shaft Nema C flg. IEC flg.	3-551-410-096-00 3-551-41C-096-(frame size) 3-551-41E-096-(frame size)	9.60	182 / 10.5 (7.8)	151 / 9.1 (6.7)	120 / 7.6 (5.6)	99 / 5.7 (4.2)
Solid Shaft Nema C flg. IEC flg.	3-551-410-112-00 3-551-41C-112-(frame size) 3-551-41E-112-(frame size)	11.2	157 / 9.7 (7.2)	129 / 8.4 (6.2)	103 / 7.1 (5.3)	85 / 5.3 (3.9)
Solid Shaft Nema C flg. IEC flg.	3-551-410-124-00 3-551-41C-124-(frame size) 3-551-41E-124-(frame size)	12.4	141 / 8.9 (6.6)	117 / 7.7 (5.7)	93 / 6.5 (4.8)	77 / 4.8 (3.5)
Solid Shaft Nema C flg. IEC flg.	3-551-410-142-00 3-551-41C-142-(frame size) 3-551-41E-142-(frame size)	14.2	123 / 8.1 (6.0)	102 / 6.9 (5.1)	81 / 5.7 (4.2)	67 / 4.3 (3.2)
Solid Shaft Nema C flg. IEC flg.	3-551-410-158-00 3-551-41C-158-(frame size) 3-551-41E-158-(frame size)	15.8	111 / 7.4 (5.5)	92 / 6.3 (4.7)	73 / 5.2 (3.8)	60 / 3.8 (2.8)
Solid Shaft Nema C flg. IEC flg.	3-551-410-178-00 3-551-41C-178-(frame size) 3-551-41E-178-(frame size)	17.8	98 / 7.0 (5.2)	81 / 5.8 (4.3)	65 / 4.6 (3.4)	53 / 3.4 (2.5)
Solid Shaft Nema C flg. IEC flg.	3-551-410-198-00 3-551-41C-198-(frame size) 3-551-41E-198-(frame size)	19.8	88 / 6.3 (4.7)	73 / 5.2 (3.8)	58 / 4.1 (3.0)	48 / 3.1 (2.3)
Solid Shaft Nema C flg. IEC flg.	3-551-410-226-00 3-551-41C-226-(frame size) 3-551-41E-226-(frame size)	22.6	77 / 5.7 (4.2)	64 / 4.7 (3.5)	51 / 3.6 (2.6)	42 / 2.7 (2.0)
Solid Shaft Nema C flg. IEC flg.	3-551-410-250-00 3-551-41C-250-(frame size) 3-551-41E-250-(frame size)	25.0	70 / 5.2 (3.8)	58 / 4.2 (3.1)	46 / 3.3 (2.4)	38 / 2.4 (1.8)
Solid Shaft Nema C flg. IEC flg.	3-551-410-283-00 3-551-41C-283-(frame size) 3-551-41E-283-(frame size)	28.3	62 / 4.6(3.4)	51 / 3.7 (2.7)	41 / 2.9 (2.1)	34 / 2.1 (1.5)
Solid Shaft Nema C flg. IEC flg.	3-551-410-314-00 3-551-41C-314-(frame size) 3-551-41E-314-(frame size)	31.4	56 / 4.1 (3.0)	46 / 3.4 (2.5)	37 / 2.6 (1.9)	30 / 1.9 (1.4)

Size 41 Approx. weights Pre-filled with oil	Weights – Lbs. (Kg)			
	Solid Shaft	145TC & 90 IEC	184TC & 112 IEC	215TC & 132 IEC
	66 (31)	71 (32)	77 (35)	79 (36)

Viking In-Line Helical Gear Reducers

Section	615
Page	615.9
Issue	C

SPECIFICATIONS: SIZE 51

Output Speed / Maximum Horsepower (kW) at Given Input Speed						
Viking Part No.	Ratio	1750 rpm	1450 rpm	1150 rpm	950 rpm	
Solid Shaft Nema C flg. IEC flg.	3-551-510-026-00 3-551-51C-026-(frame size) 3-551-51E-026-(frame size)	2.63	665 / 39.8 (29.7)	551 / 32.4 (24.1)	437 / 25.0 (18.6)	361 / 18.8 (14.0)
Solid Shaft Nema C flg. IEC flg.	3-551-510-033-00 3-551-51C-033-(frame size) 3-551-51E-033-(frame size)	3.31	529 / 32.9 (24.5)	438 / 26.8 (20.0)	347 / 20.7 (15.4)	287 / 15.5 (11.5)
Solid Shaft Nema C flg. IEC flg.	3-551-510-045-00 3-551-51C-045-(frame size) 3-551-51E-045-(frame size)	4.45	393 / 25.0 (18.6)	326 / 20.4 (15.2)	258 / 15.7 (11.7)	213 / 11.8 (8.8)
Solid Shaft Nema C flg. IEC flg.	3-551-510-056-00 3-551-51C-056-(frame size) 3-551-51E-056-(frame size)	5.63	311 / 20.1 (15.0)	257 / 16.4 (12.2)	204 / 12.6 (9.4)	169 / 9.5 (7.0)
Solid Shaft Nema C flg. IEC flg.	3-551-510-070-00 3-551-51C-070-(frame size) 3-551-51E-070-(frame size)	6.99	250 / 23.3 (17.3)	207 / 20.1 (15.0)	164 / 17.0 (12.6)	136 / 12.7 (9.4)
Solid Shaft Nema C flg. IEC flg.	3-551-510-078-00 3-551-51C-078-(frame size) 3-551-51E-078-(frame size)	7.75	222 / 21.2 (15.8)	187 / 18.3 (13.6)	148 / 15.4 (11.4)	123 / 11.6 (8.6)
Solid Shaft Nema C flg. IEC flg.	3-551-510-088-00 3-551-51C-088-(frame size) 3-551-51E-088-(frame size)	8.79	199 / 20.1 (15.0)	165 / 17.4 (13.0)	131 / 14.7 (10.9)	108 / 11.0 (8.2)
Solid Shaft Nema C flg. IEC flg.	3-551-510-098-00 3-551-51C-098-(frame size) 3-551-51E-098-(frame size)	9.75	179 / 18.1 (13.5)	149 / 15.7 (11.7)	118 / 13.3 (9.9)	97 / 10.0 (7.4)
Solid Shaft Nema C flg. IEC flg.	3-551-510-118-00 3-551-51C-118-(frame size) 3-551-51E-118-(frame size)	11.8	148 / 16.9 (12.6)	122 / 13.9 (10.3)	97 / 11.0 (8.2)	80 / 8.3 (6.2)
Solid Shaft Nema C flg. IEC flg.	3-551-510-131-00 3-551-51C-131-(frame size) 3-551-51E-131-(frame size)	13.1	134 / 14.8 (11.0)	111 / 12.4 (9.2)	88 / 9.9 (7.3)	72 / 7.4 (5.5)
Solid Shaft Nema C flg. IEC flg.	3-551-510-150-00 3-551-51C-150-(frame size) 3-551-51E-150-(frame size)	15.0	117 / 13.8 (10.3)	97 / 11.2 (8.3)	77 / 8.7 (6.5)	63 / 6.5 (4.8)
Solid Shaft Nema C flg. IEC flg.	3-551-510-166-00 3-551-51C-166-(frame size) 3-551-51E-166-(frame size)	16.6	105 / 12.4 (9.2)	87 / 10.1 (7.5)	69 / 7.8 (5.8)	57 / 5.9 (4.4)
Solid Shaft Nema C flg. IEC flg.	3-551-510-189-00 3-551-51C-189-(frame size) 3-551-51E-189-(frame size)	18.9	93 / 10.9 (8.1)	77 / 8.9 (6.6)	61 / 6.9 (5.1)	50 / 5.2 (3.8)
Solid Shaft Nema C flg. IEC flg.	3-551-510-210-00 3-551-51C-210-(frame size) 3-551-51E-210-(frame size)	21.0	83 / 9.8 (7.3)	69 / 8.0 (5.9)	55 / 6.2 (4.6)	45 / 5.2 (3.8)
Solid Shaft Nema C flg. IEC flg.	3-551-510-234-00 3-551-51C-234-(frame size) 3-551-51E-234-(frame size)	23.4	75 / 8.8 (6.5)	62 / 7.2 (5.3)	49 / 5.6 (4.1)	41 / 4.2 (3.1)
Solid Shaft Nema C flg. IEC flg.	3-551-510-259-00 3-551-51C-259-(frame size) 3-551-51E-259-(frame size)	25.9	68 / 7.9 (5.9)	56 / 6.5 (4.8)	44 / 5.0 (3.7)	37 / 3.8 (2.8)
Solid Shaft Nema C flg. IEC flg.	3-551-510-298-00 3-551-51C-298-(frame size) 3-551-51E-298-(frame size)	29.8	59 / 6.9 (5.1)	49 / 5.7 (4.2)	39 / 4.4 (3.2)	32 / 3.3 (2.4)
Solid Shaft Nema C flg. IEC flg.	3-551-510-330-00 3-551-51C-330-(frame size) 3-551-51E-330-(frame size)	33.0	53 / 6.2 (4.6)	44 / 5.1 (3.8)	35 / 3.9 (2.9)	29 / 3.0 (2.2)

Size 51 Approx. weights	Weights – Lbs. (Kg)				
	Solid Shaft	184TC & 112 IEC	215TC & 132 IEC	256TC & 160 IEC	286TC & 180 IEC
	99 (45)	117(53)	119 (54)	128 (58)	133 (61)

Section	615
Page	615.10
Issue	C

Viking In-Line Helical Gear Reducers

SPECIFICATIONS: SIZE 61

Output Speed / Maximum Horsepower (kW) at Given Input Speed						
Viking Part No.		Ratio	1750 rpm	1450 rpm	1150 rpm	950 rpm
Solid Shaft	3-551-610-028-00	2.82	621 / 50.8 (37.9)	514 / 41.8 (31.2)	408 / 32.8 (24.4)	337 / 24.6 (18.3)
Nema C flg.	3-551-61C-028-(frame size)					
IEC flg.	3-551-61E-028-(frame size)					
Solid Shaft	3-551-610-037-00	3.70	473 / 40.2 (30.0)	392 / 33.8 (25.2)	311 / 27.4 (20.4)	258 / 20.6 (15.3)
Nema C flg.	3-551-61C-037-(frame size)					
IEC flg.	3-551-61E-037-(frame size)					
Solid Shaft	3-551-610-046-00	4.56	384 / 33.7 (25.1)	318 / 28.6 (21.3)	252 / 23.5 (17.5)	208 / 17.6 (13.1)
Nema C flg.	3-551-61C-046-(frame size)					
IEC flg.	3-551-61E-046-(frame size)					
Solid Shaft	3-551-610-060-00	6.00	292 / 26.9 (20.0)	242 / 22.5 (16.7)	192 / 18.0 (13.4)	158 / 13.5 (10.0)
Nema C flg.	3-551-61C-060-(frame size)					
IEC flg.	3-551-61E-060-(frame size)					
Solid Shaft	3-551-610-067-00	6.74	260 / 43.6 (32.5)	215 / 38.1 (28.4)	171 / 33.6 (25.0)	141 / 24.5 (18.2)
Nema C flg.	3-551-61C-067-(frame size)					
IEC flg.	3-551-61E-067-(frame size)					
Solid Shaft	3-551-610-075-00	7.48	234 / 43.3 (32.3)	194 / 36.2 (27.0)	154 / 29.1 (21.7)	127 / 21.9 (16.3)
Nema C flg.	3-551-61C-075-(frame size)					
IEC flg.	3-551-61E-075-(frame size)					
Solid Shaft	3-551-610-088-00	8.84	198 / 36.9 (27.5)	164 / 30.9 (23.0)	130 / 24.8 (18.5)	107 / 18.6 (13.8)
Nema C flg.	3-551-61C-088-(frame size)					
IEC flg.	3-551-61E-088-(frame size)					
Solid Shaft	3-551-610-098-00	9.82	178 / 35.5 (26.4)	148 / 28.9 (21.5)	117 / 22.3 (16.6)	97 / 16.7 (12.4)
Nema C flg.	3-551-61C-098-(frame size)					
IEC flg.	3-551-61E-098-(frame size)					
Solid Shaft	3-551-610-109-00	10.9	161 / 31.9 (23.8)	133 / 26.0 (19.4)	106 / 20.1 (15.0)	87 / 15.0 (11.1)
Nema C flg.	3-551-61C-109-(frame size)					
IEC flg.	3-551-61E-109-(frame size)					
Solid Shaft	3-551-610-121-00	12.1	145 / 28.7 (21.4)	120 / 23.4 (17.4)	95 / 18.1 (13.5)	78 / 13.6 (10.1)
Nema C flg.	3-551-61C-121-(frame size)					
IEC flg.	3-551-61E-121-(frame size)					
Solid Shaft	3-551-610-143-00	14.3	122 / 24.3 (18.1)	101 / 19.8 (13.2)	80 / 15.3 (11.4)	66 / 11.5 (8.5)
Nema C flg.	3-551-61C-143-(frame size)					
IEC flg.	3-551-61E-143-(frame size)					
Solid Shaft	3-551-610-159-00	15.9	110 / 21.9 (16.3)	91 / 17.8 (13.2)	72 / 13.7 (10.2)	60 / 10.3 (7.6)
Nema C flg.	3-551-61C-159-(frame size)					
IEC flg.	3-551-61E-159-(frame size)					
Solid Shaft	3-551-610-177-00	17.7	99 / 19.6 (14.6)	82 / 16.0 (11.9)	65 / 12.4 (9.2)	54 / 9.3 (6.9)
Nema C flg.	3-551-61C-177-(frame size)					
IEC flg.	3-551-61E-177-(frame size)					
Solid Shaft	3-551-610-196-00	19.6	89 / 17.7 (13.2)	74 / 14.4 (10.7)	59 / 11.2 (8.3)	48 / 8.4 (6.2)
Nema C flg.	3-551-61C-196-(frame size)					
IEC flg.	3-551-61E-196-(frame size)					
Solid Shaft	3-551-610-224-00	22.4	78 / 15.5(11.5)	65 / 12.6 (9.4)	51 / 9.8 (7.3)	42 / 7.3 (5.4)
Nema C flg.	3-551-61C-224-(frame size)					
IEC flg.	3-551-61E-224-(frame size)					
Solid Shaft	3-551-610-248-00	24.8	71 / 14.0 (10.4)	58 / 11.9 (8.8)	46 / 8.8 (6.5)	38 / 6.6 (4.9)
Nema C flg.	3-551-61C-248-(frame size)					
IEC flg.	3-551-61E-248-(frame size)					
Solid Shaft	3-551-610-274-00	27.4	64 / 12.7 (9.4)	53 / 10.3 (7.6)	42 / 8.0 (5.9)	35 / 6.0 (4.4)
Nema C flg.	3-551-61C-274-(frame size)					
IEC flg.	3-551-61E-274-(frame size)					
Solid Shaft	3-551-610-304-00	30.4	58 / 11.4 (8.5)	48 / 9.3 (6.9)	38 / 7.2 (5.3)	31 / 5.4 (4.0)
Nema C flg.	3-551-61C-304-(frame size)					
IEC flg.	3-551-61E-304-(frame size)					
Solid Shaft	3-551-610-342-00	34.2	51 / 9.2 (6.8)	42 / 7.6 (5.6)	34 / 6.0 (4.4)	28 / 4.5 (3.3)
Nema C flg.	3-551-61C-342-(frame size)					
IEC flg.	3-551-61E-342-(frame size)					
Solid Shaft	3-551-610-380-00	38.0	46 / 9.2 (6.8)	38 / 7.5 (5.6)	30 / 5.8 (4.3)	25 / 4.3 (3.2)
Nema C flg.	3-551-61C-380-(frame size)					
IEC glf.	3-551-60E-304-(frame size)					

Weights found on page 11

Viking In-Line Helical Gear Reducers

Section	615
Page	615.11
Issue	C

SPECIFICATION: SIZE 70

Output Speed / Maximum Horsepower (kW) at Given Input Speed						
Viking Part No.	Ratio	1750 rpm	1450 rpm	1150 rpm	950 rpm	
Solid Shaft 3-551-700-046-00	4.57	383 / 95.3 (71.0)	317 / 79.4 (59.2)	252 / 63.5 (47.3)	208 / 47.6 (35.5)	
Solid Shaft 3-551-700-059-00	5.85	299 / 83.2 (62.0)	248 / 68.5 (51.1)	197 / 53.9 (40.2)	162 / 40.4 (30.1)	
Solid Shaft 3-551-700-063-00	6.25	280 / 80.3 (59.9)	232 / 67.2 (50.1)	184 / 54.2 (40.4)	152 / 40.7 (30.3)	
Solid Shaft 3-551-700-075-00	7.46	235 / 67.4 (50.2)	194 / 56.5 (42.1)	154 / 45.6 (34.0)	127 / 34.2 (25.5)	
Solid Shaft 3-551-700-080-00	8.00	219 / 68.0 (50.7)	181 / 55.3 (41.2)	144 / 42.7 (31.8)	119 / 32.0 (23.8)	
Solid Shaft 3-551-700-095-00	9.52	184 / 54.5 (40.6)	152 / 45.6 (34.0)	121 / 36.7 (27.3)	100 / 27.6 (20.5)	
Solid Shaft 3-551-700-102-00	10.2	171 / 53.3 (39.8)	142 / 43.4 (32.3)	113 / 33.5 (25.0)	93 / 25.1 (18.7)	
Solid Shaft 3-551-700-112-00	11.2	156 / 46.2 (34.4)	129 / 38.7 (28.8)	103 / 31.2 (23.2)	85 / 23.4 (17.4)	
Solid Shaft 3-551-700-130-00	13.0	135 / 41.8 (31.1)	111 / 34.0 (25.3)	88 / 26.3 (19.6)	73 / 19.7 (14.7)	
Solid Shaft 3-551-700-141-00	14.1	124 / 38.6 (28.8)	103 / 31.7 (23.6)	82 / 24.8 (18.5)	67 / 18.6 (13.8)	
Solid Shaft 3-551-700-153-00	15.3	114 / 35.5 (26.4)	95 / 28.9 (21.5)	75 / 22.3 (16.6)	62 / 16.7 (12.4)	
Solid Shaft 3-551-700-167-00	16.7	105 / 31.7 (23.6)	87 / 25.8 (19.2)	69 / 19.9 (14.8)	57 / 14.9 (11.1)	
Solid Shaft 3-551-700-193-00	19.3	91 / 28.2 (21.0)	75 / 22.4 (16.7)	60 / 17.7 (13.2)	49 / 13.3 (9.9)	
Solid Shaft 3-551-700-229-00	22.9	76 / 23.7 (17.6)	63 / 19.3 (14.4)	50 / 14.9 (11.1)	41 / 11.2 (8.3)	
Solid Shaft 3-551-700-277-00	27.7	63 / 19.6 (14.6)	52 / 16.0 (11.9)	42 / 12.3 (9.1)	34 / 9.3 (6.9)	
Solid Shaft 3-551-700-347-00	34.7	50 / 15.7 (11.7)	42 / 12.8 (9.5)	33 / 9.8 (7.3)	27 / 7.4 (5.5)	

Size 70 Approx. weights	Weights – Lbs. (Kg)
	Solid Shaft
	238 (106)

Reducer Weight - Size 61 (Specifications on Page 10)

Size 61 Approx. weights	Weights – Lbs. (Kg)				
	Solid Shaft	184TC & 112 IEC	215 TC & 132 IEC	256TC & 160 IEC	286TC & 180 IEC
	145 (66)	150 (68)	157 (71)	161 (73)	165 (75)

Section	615
Page	615.12
Issue	C

Viking In-Line Helical Gear Reducers

SPECIFICATION: SIZE 80

Output Speed/Maximum Horsepower (kW) at Given Input Speed						
	Viking Part No.	Ratio	1750 rpm	1450 rpm	1150 rpm	950 rpm
Solid Shaft	3-551-800-056-00	5.64	310 / 143 (107)	257 / 122 (91.0)	204 / 101 (75.3)	168 / 76.3 (56.9)
Solid Shaft	3-551-800-061-00	6.11	286 / 134 (100)	237 / 115 (85.8)	188 / 96.1 (71.7)	155 / 72.1 (53.7)
Solid Shaft	3-551-800-070-00	7.04	249 / 124 (92.5)	206 / 102 (76.1)	163 / 81.4 (60.7)	135 / 61.0 (45.5)
Solid Shaft	3-551-800-076-00	7.63	229 / 116 (86.5)	190 / 96.9 (72.2)	150 / 78.1 (58.2)	125 / 58.6 (43.7)
Solid Shaft	3-551-800-089-00	8.86	197 / 102 (76.1)	164 / 82.9 (61.8)	130 / 64.0 (47.7)	107 / 48.0 (35.8)
Solid Shaft	3-551-800-096-00	9.60	182 / 100 (74.6)	151 / 81.1 (60.5)	120 / 62.6 (46.7)	99 / 46.9 (35.0)
Solid Shaft	3-551-800-111-00	11.1	158 / 81.6 (61.8)	131 / 66.5 (49.6)	104 / 51.3 (38.2)	86 / 38.5 (28.7)
Solid Shaft	3-551-800-120-00	12.0	146 / 79.6 (59.3)	121 / 64.9 (48.4)	96 / 50.1 (37.3)	79 / 37.5 (27.9)
Solid Shaft	3-551-800-138-00	13.8	127 / 65.7 (49.0)	105 / 53.5 (39.9)	83 / 41.3 (30.8)	69 / 31.0 (23.1)
Solid Shaft	3-551-800-149-00	14.9	117 / 64.1 (47.8)	97 / 52.2 (38.9)	77 / 40.3 (30.0)	64 / 30.2 (22.5)
Solid Shaft	3-551-800-167-00	16.7	105 / 54.3 (40.5)	87 / 44.2 (33.0)	68 / 34.1 (25.4)	57 / 25.6 (19.1)
Solid Shaft	3-551-800-181-00	18.1	97 / 52.8 (39.3)	80 / 43.0 (32.0)	64 / 33.3 (24.8)	52 / 24.9 (18.5)
Solid Shaft	3-551-800-205-00	20.5	85 / 44.8 (33.4)	71 / 36.5 (27.2)	56 / 28.1 (21.0)	46 / 21.1 (15.7)
Solid Shaft	3-551-800-222-00	22.2	79 / 43.0 (32.0)	65 / 35.1 (26.1)	52 / 27.1 (20.2)	43 / 20.3 (15.1)
Solid Shaft	3-551-800-240-00	24.0	73 / 38.2 (28.5)	60 / 31.1 (23.2)	48 / 24.0 (17.9)	40 / 18.0 (13.4)
Solid Shaft	3-551-800-259-00	25.9	68 / 36.9 (27.5)	56 / 30.0 (22.3)	44 / 23.2 (17.3)	37 / 17.4 (13.0)
Solid Shaft	3-551-800-313-00	31.3	56 / 30.5 (22.7)	46 / 24.9 (18.5)	37 / 19.2 (14.3)	30 / 14.4 (10.7)

Size 80 Approx. Weights	Weights – Lbs. (Kg)
	Solid Shaft
	339 (154)

Viking In-Line Helical Gear Reducers

Section	615
Page	615.13
Issue	C

SPECIFICATIONS: SIZE 90

Output Speed / Maximum Horsepower (kW) at Given Input Speed						
Viking Part No.	Ratio	1750 rpm	1450 rpm	1150 rpm	950 rpm	
Solid Shaft 3-551-900-052-00	5.17	338 / 214 (159)	280 / 184 (137)	222 / 153 (114)	184 / 115 (85.8)	
Solid Shaft 3-551-900-056-00	5.60	312 / 203 (151)	259 / 175 (130)	205 / 147 (110)	170 / 110 (82.0)	
Solid Shaft 3-551-900-068-00	6.76	259 / 180 (134)	214 / 155 (116)	170 / 130 (97.0)	141 / 97.7 (72.8)	
Solid Shaft 3-551-900-073-00	7.32	239 / 172 (128)	198 / 148 (110)	157 / 124 (92.5)	130 / 92.7 (69.1)	
Solid Shaft 3-551-900-083-00	8.33	210 / 159 (118)	174 / 137 (102)	138 / 115 (85.8)	114 / 86.0 (64.1)	
Solid Shaft 3-551-900-090-00	9.02	194 / 149 (111)	161 / 128 (95.5)	127 / 108 (80.5)	105 / 80.7 (60.2)	
Solid Shaft 3-551-900-104-00	10.4	169 / 138 (103)	140 / 117 (87.3)	111 / 97.4 (72.6)	91 / 72.7 (54.2)	
Solid Shaft 3-551-900-112-00	11.2	156 / 130 (97)	129 / 112 (83.5)	103 / 93.7 (69.9)	85 / 70.2 (52.3)	
Solid Shaft 3-551-900-128-00	12.8	137 / 120 (89)	113 / 99.8 (74.4)	90 / 79.4 (59.2)	74 / 59.5 (44.3)	
Solid Shaft 3-551-900-139-00	13.9	126 / 112 (83)	104 / 94.6 (70.5)	83 / 76.7 (57.2)	68 / 57.5 (42.9)	
Solid Shaft 3-551-900-160-00	16.0	109 / 100 (74)	90 / 81.7 (60.9)	72 / 63.0 (47.0)	59 / 47.3 (35.3)	
Solid Shaft 3-551-900-173-00	17.3	101 / 97.1 (72.4)	83 / 79.4 (59.2)	66 / 61.6 (45.9)	55 / 46.2 (34.4)	
Solid Shaft 3-551-900-187-00	18.7	94 / 85.8 (64.0)	78 / 69.9 (52.1)	61 / 53.9 (40.2)	51 / 40.4 (30.1)	
Solid Shaft 3-551-900-202-00	20.2	87 / 84.5 (63.0)	72 / 68.8 (51.3)	57 / 53.1 (39.6)	47 / 39.8 (29.7)	
Solid Shaft 3-551-900-229-00	22.9	76 / 70.1 (52.3)	63 / 57.1 (42.6)	50 / 44.0 (32.8)	41 / 33.0 (24.6)	
Solid Shaft 3-551-900-248-00	24.8	71 / 68.8 (51.3)	58 / 56.0 (41.7)	46 / 43.3 (32.3)	38 / 32.4 (24.1)	
Solid Shaft 3-551-900-272-00	27.2	64 / 52.3 (39.0)	53 / 42.6 (31.7)	42 / 32.9 (24.5)	35 / 24.7 (18.4)	
Solid Shaft 3-551-900-294-00	29.4	60 / 51.9 (38.7)	49 / 42.3 (31.5)	39 / 32.6 (24.3)	32 / 24.5 (18.2)	
Solid Shaft 3-551-900-351-00	35.1	50 / 39.8 (29.6)	41 / 32.4 (24.1)	33 / 25.0 (18.6)	27 / 18.8 (14.0)	

Size 90 Approx. weights	Weights – Lbs. (Kg)
	Solid Shaft
	601 (273)

Section	615
Page	615.14
Issue	C

Viking In-Line Helical Gear Reducers

SPECIFICATIONS: SIZE 100

Output Speed / Maximum Horsepower (kW) at Given Input Speed						
Viking Part No.	Ratio	1750 rpm	1450 rpm	1150 rpm	950 rpm	
Solid Shaft 3-551-100-049-00	4.92	356 / 359 (267)	295 / 309 (230)	234 / 259 (193)	193 / 194 (144)	
Solid Shaft 3-551-100-053-00	5.33	328 / 339 (252)	272 / 292 (217)	216 / 244 (182)	178 / 183 (136)	
Solid Shaft 3-551-100-065-00	6.52	268 / 300 (223)	222 / 258 (192)	176 / 215 (160)	146 / 161 (120)	
Solid Shaft 3-551-100-071-00	7.07	247 / 279 (208)	205 / 239 (178)	163 / 200 (149)	134 / 150 (112)	
Solid Shaft 3-551-100-083-00	8.35	210 / 253 (188)	174 / 217 (161)	138 / 181 (135)	114 / 136 (101)	
Solid Shaft 3-551-100-090-00	9.05	193 / 240 (179)	160 / 206 (153)	127 / 172 (128)	105 / 129 (96.2)	
Solid Shaft 3-551-100-101-00	10.1	173 / 220 (167)	143 / 192 (143)	114 / 161 (120)	94 / 121 (90.2)	
Solid Shaft 3-551-100-109-00	10.9	160 / 207 (154)	133 / 179 (133)	105 / 151 (112)	87 / 113 (84.3)	
Solid Shaft 3-551-100-125-00	12.5	140 / 194 (144)	116 / 167 (124)	92 / 139 (103)	76 / 104 (77.5)	
Solid Shaft 3-551-100-135-00	13.5	130 / 182 (135)	107 / 156 (116)	85 / 130 (97.0)	70 / 98.0 (73.1)	
Solid Shaft 3-551-100-152-00	15.2	115 / 170 (126)	95 / 143 (106)	76 / 115 (85.8)	63 / 86.7 (76.7)	
Solid Shaft 3-551-100-165-00	16.5	106 / 159 (118)	88 / 136 (101)	70 / 113 (84.3)	58 / 85.0 (63.4)	
Solid Shaft 3-551-100-187-00	18.7	94 / 138 (103)	77 / 117 (87.2)	61 / 94.8 (70.7)	51 / 71.1 (53.0)	
Solid Shaft 3-551-100-202-00	20.2	87 / 128 (95.5)	72 / 110 (82.0)	57 / 92.6 (69.0)	47 / 69.4 (51.7)	
Solid Shaft 3-551-100-222-00	22.2	79 / 107 (79.8)	65 / 89.7 (66.9)	52 / 72.2 (53.8)	43 / 54.1 (40.3)	
Solid Shaft 3-551-100-241-00	24.1	73 / 107 (79.8)	60 / 90.1 (67.2)	48 / 72.9 (54.3)	39 / 54.7 (40.8)	
Solid Shaft 3-551-100-296-00	29.6	59 / 74 (55.2)	49 / 62.1 (46.3)	39 / 50.0 (37.3)	32 / 37.5 (27.9)	

Size 100 Approx. weights	Weights – Lbs. (Kg)
	Solid Shaft
	900 (409)

Viking In-Line Helical Gear Reducers

Section	615
Page	615.15
Issue	C

REPAIR PARTS

Special tools and training are required to repair multi-reduction gearboxes. Replacement of gears, shafts and bearings, combined with labor makes repairs impractical.

Repair parts for in-line reducers are limited to a seal kit consisting of oil seals and gaskets. The table below lists the part number for the repair kit for each reducer size and configuration.

Size	Input Shaft	Repair Kit No.
11	Solid Shaft	3-462-ILINE11-001
	56C	3-462-ILINE11-002
	143/145TC	3-462-ILINE11-003
	182/184TC	3-462-ILINE11-004
	63 IEC	3-462-ILINE11-005
	71 IEC	3-462-ILINE11-006
	80 IEC	3-462-ILINE11-007
	90 IEC	3-462-ILINE11-008
	100/112 IEC	3-462-ILINE11-009
21	Solid Shaft	3-462-ILINE21-001
	56C	3-462-ILINE21-002
	143/145 TC	3-462-ILINE21-003
	182/184 TC	3-462-ILINE21-004
	63 IEC	3-462-ILINE21-005
	71 IEC	3-462-ILINE21-006
	80 IEC	3-462-ILINE21-007
	90 IEC	3-462-ILINE21-008
	100/112 IEC	3-462-ILINE21-009
31	Solid Shaft	3-462-ILINE31-001
	143/145 TC	3-462-ILINE31-002
	182/184 TC	3-462-ILINE31-003
	80 IEC	3-462-ILINE31-004
	90 IEC	3-462-ILINE31-005
	100/112 IEC	3-462-ILINE31-006
35	Solid Shaft	3-462-ILINE35-001
	143/145 TC	3-462-ILINE35-002
	182/184 TC	3-462-ILINE35-003
	213/215 TC	3-462-ILINE35-004
	80 IEC	3-462-ILINE35-005
	90 IEC	3-462-ILINE35-006
	100/112 IEC	3-462-ILINE35-007
	132 IEC	3-462-ILINE35-008

Size	Input Shaft	Repair Kit No.
41	Solid Shaft	3-462-ILINE41-001
	143/145 TC	3-462-ILINE41-002
	182/184 TC	3-462-ILINE41-003
	213/215TC	3-462-ILINE41-004
	80 IEC	3-462-ILINE41-005
	90 IEC	3-462-ILINE41-006
	100/112 IEC	3-462-ILINE41-007
	132 IEC	3-462-ILINE41-008
51	Solid Shaft	3-462-ILINE51-001
	182/184 TC	3-462-ILINE51-002
	213/215 TC	3-462-ILINE51-003
	254/256 TC	3-462-ILINE51-004
	284/286 TC	3-462-ILINE51-005
	100/112 IEC	3-462-ILINE51-006
	132 IEC	3-462-ILINE51-007
	160 IEC	3-462-ILINE51-008
	180 IEC	3-462-ILINE51-009
61	Solid Shaft	3-462-ILINE61-001
	182/184 TC	3-462-ILINE61-002
	213/215TC	3-462-ILINE61-003
	254/256 TC	3-462-ILINE61-004
	284/286 TC	3-462-ILINE61-005
	100/112 IEC	3-462-ILINE61-006
	132	3-462-ILINE61-007
	160	3-462-ILINE61-008
	180	3-462-ILINE61-009
70	Solid Shaft	3-462-ILINE70-001
80	Solid Shaft	3-462-ILINE80-001
90	Solid Shaft	3-462-ILINE90-001
100	Solid Shaft	3-462-ILINE100-001

Section	615
Page	615.16
Issue	C

Viking In-Line Helical Gear Reducers

Solid Input Shaft Model Dimensions

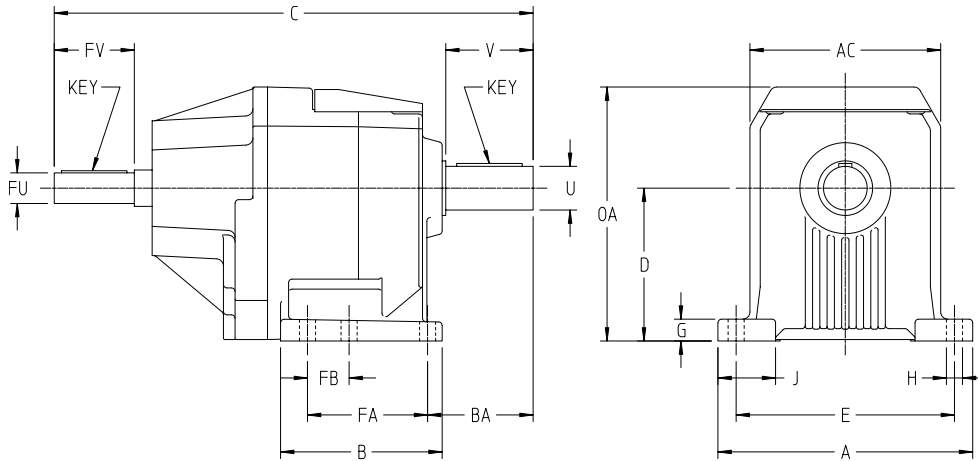

Size		A	AC	B	BA	C	D	E	FA	FB	G	H	J	OA	V	FV
11	in	5.12	3.74	4.21	2.28	9.90	3.35	4.33	3.43	1.46	.59	.35	1.46	5.55	1.56	1.57
	mm	130	95	107	58	251	85	110	87	37	15	9	37	14	40	40
21	in	6.10	4.33	5.39	2.68	12.75	3.94	5.12	4.23	1.87	.67	.43	1.77	6.54	2.00	1.57
	mm	155	110	137	68	324	100	130	107.5	47.5	17	11	45	166	50	40
31	in	7.48	5.12	6.14	3.07	14.09	4.33	6.30	5.12	2.36	.79	.43	2.09	7.13	2.38	1.57
	mm	190	130	156	78	358	110	160	130	60	20	11	53	181	60	40
35	in	8.07	5.91	6.61	3.58	16.32	4.53	6.69	5.12	n.a.	.63	.55	1.97	8.11	2.71	1.97
	mm	205	150	168	91	414.5	115	170	130	n.a.	16	14	50	206	69	50
41	in	8.50	6.10	7.30	3.52	16.71	5.12	7.09	5.88	n.a.	.71	.55	2.40	8.70	2.71	1.97
	mm	216	155	185.5	89.5	424.5	130	180	149.5	n.a.	18	14	61	221	69	50
51	in	10.63	7.28	7.87	4.13	17.75	6.10	8.86	6.14	n.a.	.87	.71	2.95	10.94	3.12	1.97
	mm	270	185	200	105	450.9	155	225	156	n.a.	22	18	75	278	80	50
61	in	11.81	8.27	9.13	4.36	20.37	7.68	9.84	7.09	n.a.	.98	.71	3.15	12.44	3.38	2.36
	mm	300	210	232	111	517	195	250	180	n.a.	25	18	80	316	86	60
70	in	13.78	10.31	8.74	5.71	25.89	8.27	11.81	6.50	n.a.	1.18	.87	3.35	13.74	4.72	4.33
	mm	350	262	222	145	657.5	210	300	165	n.a.	30	22	85	349	120	110
80	in	17.32	12.60	10.91	6.81	28.29	9.84	14.57	8.27	n.a.	1.38	1.02	4.33	16.54	5.51	4.33
	mm	440	320	277	173	718.5	250	370	210	n.a.	35	26	110	420	140	110
90	in	20.47	14.76	13.35	8.27	36.63	11.81	17.32	9.84	n.a.	1.57	1.30	5.51	19.49	6.69	5.51
	mm	520	375	339	210	930.5	300	440	250	n.a.	40	33	140	495	170	140
100	in	22.05	17.32	15.31	10.04	40.37	13.58	19.29	11.42	n.a.	1.77	1.30	6.30	22.44	8.27	5.51
	mm	560	440	389	255	1025	345	490	290	n.a.	45	33	160	570	210	140

Size		U	Key	FU	Key
11	in	.750	.19x.19x1.38	.625	.19x.19x1.38
21	in	1.000	.25x.25x1.75	.750	.19x.19x1.38
31	in	1.125	.25x.25x2.16	.750	.19x.19x1.38
35	in	1.375	.31x.31x2.38	1.000	.25x.25x1.75
41	in	1.375	.31x.31x2.38	1.000	.25x.25x1.75
51	in	1.562	.38x.38x2.88	1.000	.25x.25x1.75
61	in	2.000	.50x.50x3.16	1.125	.25x.25x2.16
70	mm	60	18x11x90	42	12x8x90
80	mm	80	22x14x110	42	12x8x90
90	mm	90	25x14x140	60	18x11x120
100	mm	100	28x16x180	60	18x11x120

Viking In-Line Helical Gear Reducers

Section	615
Page	615.17
Issue	D

NEMA "C" Face Model Dimensions

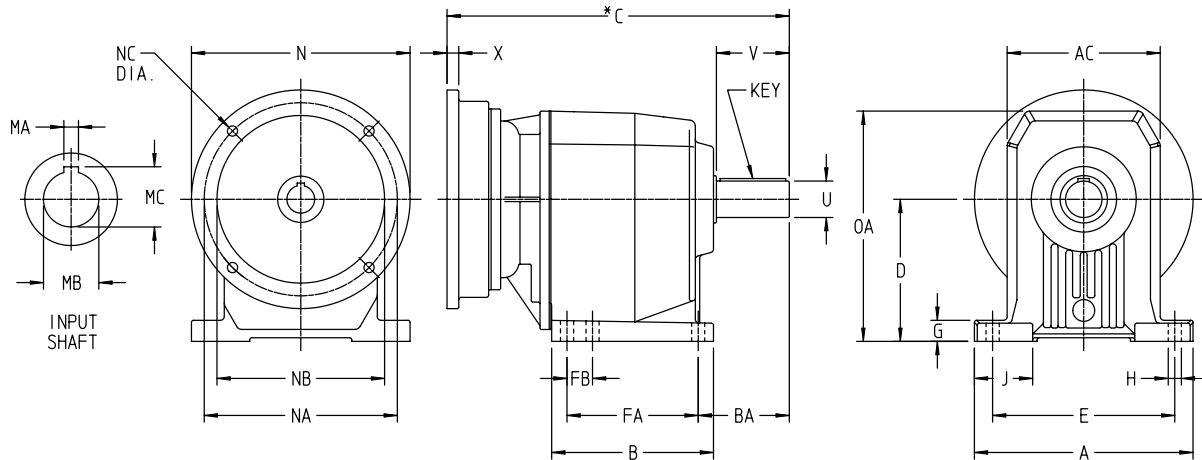

Size		A	AC	B	BA	D	E	FA	FB	G	H	J	OA	V	U	KEY
11	in	5.12	3.74	4.21	2.28	3.35	4.33	3.43	1.46	.59	.35	1.46	5.55	1.56	0.750	.19x.19x1.38
	mm	130	95	107	58	85	110	87	37	15	9	37	141	40	n.a.	n.a.
21	in	6.10	4.33	5.39	2.68	3.94	5.12	4.23	1.87	.67	.43	1.77	6.54	2.00	1.000	.25x.25x1.75
	mm	155	110	137	68	100	130	107.5	47.5	17	11	45	166	50	n.a.	n.a.
31	in	7.48	5.12	6.14	3.07	4.33	6.30	5.12	2.36	.79	.43	2.09	7.13	2.38	1.125	.25x.25x2.16
	mm	190	130	156	78	110	160	130	60	20	11	53	181	60	n.a.	n.a.
35	in	8.07	5.91	6.61	3.58	4.53	6.69	5.12	n.a.	.63	.55	1.97	8.11	2.71	1.375	.31x.31x2.38
	mm	205	150	168	93.5	115	170	130	n.a.	16	14	50	206	69	n.a.	n.a.
41	in	8.50	6.10	7.30	3.52	5.12	7.09	5.88	n.a.	.71	.55	2.40	8.70	2.71	1.375	.31x.31x2.38
	mm	216	155	185.5	89.5	130	180	149.5	n.a.	18	14	61	221	69	n.a.	n.a.
51	in	10.63	7.28	7.87	4.13	6.10	8.86	6.14	n.a.	.87	.71	2.95	10.94	3.12	1.562	.38x.38x2.88
	mm	270	185	200	105	155	225	178	n.a.	22	18	75	278	80	n.a.	n.a.
61	in	11.81	8.27	9.13	4.36	7.68	9.84	7.09	n.a.	.98	.71	3.15	12.44	3.38	2.000	.50x.50x3.16
	mm	300	210	232	111	195	250	180	n.a.	25	18	80	316	86	n.a.	n.a.

NEMA FRAME		N	NA	NB	NC	X	MA	MB	MC
56C	in	6.496	5.875	4.50	.39	.47	.188	.625	.71
143TC, 145TC	in	6.496	5.875	4.50	.39	.47	.188	.875	.96
182TC, 184TC	in	8.996	7.250	8.50	.55	.63	.250	1.125	1.24
213TC, 215TC	in	8.996	7.250	8.50	.55	.63	.312	1.375	1.52
254TC, 256TC	in	13.780	7.250	8.500	.55	.75	.375	1.625	1.80
284TC, 286TC	in	13.780	9.000	10.500	.55	.75	.500	1.875	2.10

* See Page 19 for "C" Dimensions

Section	615
Page	615.18
Issue	D

Viking In-Line Helical Gear Reducers

IEC Flange Model Dimensions

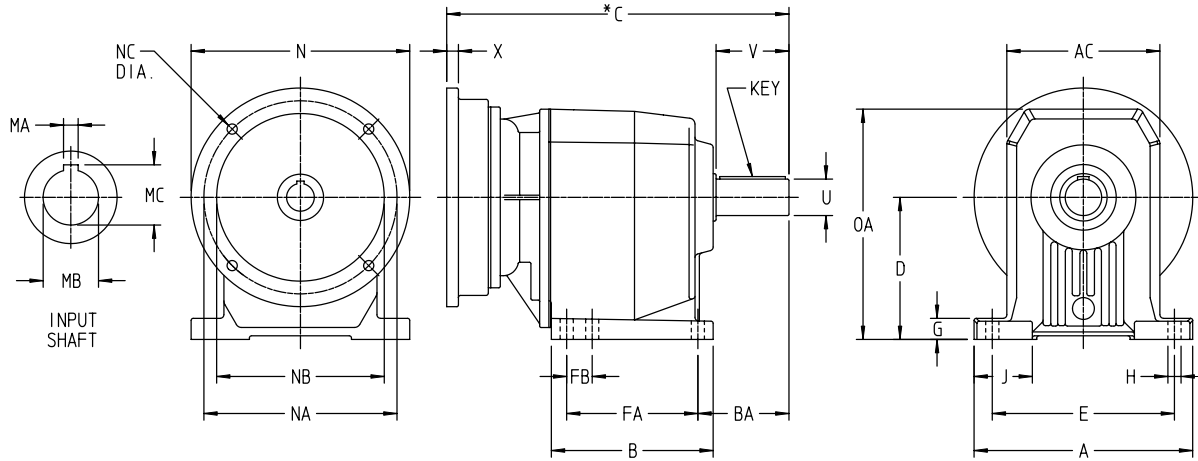

Size		A	AC	B	BA	D	E	FA	FB	G	H	J	OA	V	U	KEY
11	in	5.12	3.74	4.21	2.28	3.35	4.33	3.43	1.46	.59	.35	1.46	5.55	1.56	0.750	.19x.19x1.38
	mm	130	95	107	58	85	110	87	37	15	9	37	141	40	n.a.	n.a.
21	in	6.10	4.33	5.39	2.68	3.94	5.12	4.23	1.87	.67	.43	1.77	6.54	2.00	1.000	.25x.25x1.75
	mm	155	110	137	68	100	130	107.5	47.5	17	11	45	166	50	n.a.	n.a.
31	in	7.48	5.12	6.14	3.07	4.33	6.30	5.12	2.36	.79	.43	2.09	7.13	2.38	1.125	.25x.25x2.16
	mm	190	130	156	78	110	160	130	60	20	11	53	181	60	n.a.	n.a.
35	in	8.07	5.91	6.61	3.68	4.53	6.69	5.12	n.a.	.63	.55	1.97	8.11	2.71	1.375	.31x.31x2.38
	mm	205	150	168	93.5	115	170	130	n.a.	16	14	50	206	69	n.a.	n.a.
41	in	8.50	6.10	7.30	3.52	5.12	7.09	5.88	n.a.	.71	.55	2.40	8.70	2.71	1.375	.31x.31x2.38
	mm	216	155	185.5	89.5	130	180	149.5	n.a.	18	14	61	221	69	n.a.	n.a.
51	in	10.63	7.28	7.87	4.13	6.10	8.86	6.14	n.a.	.87	.71	2.95	10.94	3.12	1.562	.38x.38x2.88
	mm	270	185	200	105	155	225	156	n.a.	22	18	75	278	80	n.a.	n.a.
61	in	11.81	8.27	9.13	4.36	7.68	9.84	7.09	n.a.	.98	.71	3.15	12.44	3.38	2.000	.50x.50x3.16
	mm	300	210	232	111	195	250	180	n.a.	25	18	80	316	86	n.a.	n.a.

IEC FRAME **		N	NA	NB	NC	X	MA	MB	MC
63	mm	140	115	95	M8x19	16	4	11	12.8
71	mm	160	130	110	M8x16	16	5	14	16.3
80	mm	200	165	130	M10x12	16	6	19	21.8
90	mm	200	165	130	M10x12	16	8	24	27.3
100/112	mm	250	215	180	M12x16	16	8	28	31.3
132	mm	300	265	230	14	16	10	38	41.3
160	mm	350	300	250	18	19	12	42	45.3
180	mm	350	300	250	18	19	14	48	51.8

* See page 19 for "C" dimensions

** IEC flange must be B5

Viking In-Line Helical Gear Reducers

Section	615
Page	615.19
Issue	D

“C” Dimensions

NEMA C-Face Models (from page 17)

Size		56C /143TC /145TC	182/184TC	213/215TC	254/256 TC	284/286 TC
11	in	10.41	10.95	n.a.	n.a.	n.a.
	mm	264.5	278			
21	in	11.57	12.10	n.a.	n.a.	n.a.
	mm	293.8	307.3			
31	in	12.89	13.39	n.a.	n.a.	n.a.
	mm	327.5	340			
35	in	13.62	14.15	15.56	n.a.	n.a.
	mm	346	359.5	395.4		
41	in	14.04	14.57	16.02	n.a.	n.a.
	mm	356.5	370	407		
51	in	15.03	15.56	16.80	19.83	20.01
	mm	381.8	395.3	426.8	503.8	508.3
61	in	17.11	17.65	18.89	21.37	21.56
	mm	434.7	448.2	479.7	542.8	547.6

IEC Flange Models (from page 18)

Size		63	71	80	90	100	112	132	160	180
11	in	9.63	9.63	10.39	10.39	10.79	10.79	n.a.	n.a.	n.a.
	mm	244.5	244.5	264	264	274	274			
21	in	10.75	10.75	11.52	11.52	11.91	11.91	n.a.	n.a.	n.a.
	mm	273	273	292.5	292.5	302.5	302.5			
31	in	12.11	12.11	12.88	12.88	13.27	13.27	n.a.	n.a.	n.a.
	mm	307.5	307.5	327	327	337	337			
35	in	12.84	12.84	13.60	13.60	14.00	14.00	n.a.	n.a.	n.a.
	mm	326	326	345.5	345.5	355.5	355.5			
41	in	n.a.	13.25	14.02	14.02	14.41	14.41	15.85	n.a.	n.a.
	mm	n.a.	336.5	356	356	366	366	402.5		
51	in	n.a.	14.27	15.04	15.04	15.43	15.43	16.87	18.86	18.86
	mm	n.a.	362.5	382	382	392	392	428.5	479	479
61	in	n.a.	n.a.	16.54	16.54	16.89	16.89	18.37	20.35	20.35
	mm	n.a.	n.a.	420	420	429	429	466.5	517	517